



QUANTUM 2

SOLID STATE DOPPLER RADOME

INSTALLATION INSTRUCTIONS

English (en-US)
Date: 10-2023
Document number: 87342 (Rev 5)
© 2023 Raymarine UK Limited

Raymarine®

Legal notices

Trademark and patents notice

Raymarine, Tacktick, Pathfinder, ClearPulse, Truzoom, SeaTalk, SeaTalk^{hs}, SeaTalkng, and **Micronet**, are registered or claimed trademarks of Raymarine Belgium.

FLIR, Fishidy, Fishing Hot Spots, YachtSense, DockSense, LightHouse, RangeFusion, DownVision, SideVision, RealVision, HyperVision, Dragonfly, Element, Quantum, Axiom, Instalert, Infrared Everywhere, The World's Sixth Sense and **ClearCruise** are registered or claimed trademarks of FLIR Systems, Inc.

All other trademarks, trade names, or company names referenced herein are used for identification only and are the property of their respective owners.

This product is protected by patents, design patents, patents pending, or design patents pending.

Fair Use Statement

You may print no more than three copies of this manual for your own use. You may not make any further copies or distribute or use the manual in any other way including without limitation exploiting the manual commercially or giving or selling copies to third parties.

Content notice

Please ensure that you have obtained this document only from Raymarine®, and that it is the **latest** available version.

There are numerous third-party Internet websites (such as *www.manualslib.com*) hosting Raymarine product manuals. These websites are not authorized by Raymarine® to do so, and are often hosting illegitimate or older versions of Raymarine product manuals, which may contain inaccurate or misleading information.

To obtain the latest official documentation for a Raymarine® product, please visit the official Raymarine® website: www.raymarine.com/manuals

CONTENTS

CHAPTER 1 IMPORTANT INFORMATION	9		
Safety warnings	9		
Certified Installation	9		
Product warnings	9		
Regulatory notices	10		
Transmitted power density levels (from centre of rotation)	10		
IEEE statement	10		
ICNIRP Guidelines	10		
Water ingress	10		
Disclaimer	10		
EMC installation guidelines.....	11		
Compass safe distance	11		
Declaration of Conformity	11		
Connections to other equipment	11		
Product disposal	12		
Open source license agreements.....	12		
Warranty registration.....	12		
IMO and SOLAS	12		
Radar licensing	12		
FCC Notice - Radar	12		
MSIP Warning Statement for Radio Devices (Korea only)	12		
Technical accuracy	12		
Operation instructions	13		
		Retain your Wi-Fi passcode	13
		Publication copyright.....	13
CHAPTER 2 DOCUMENT INFORMATION	14		
2.1 Applicable products	15		
Special bundle and promotional products	15		
2.2 Document illustrations	15		
2.3 Product documentation	15		
2.4 Operation instructions.....	15		
CHAPTER 3 PRODUCT AND SYSTEM OVERVIEW	16		
3.1 Product overview	17		
Multiple Quantum Radar scanners	17		
Doppler Radar overview	17		
3.2 Required additional components	17		
Doppler data source requirements	18		
Radar target acquisition data source requirements	18		
Retain your Wi-Fi passcode	18		
3.3 Multifunction display compatibility	19		
Compatible multifunction displays.....	19		
Incompatible multifunction displays.....	20		
3.4 Software updates	20		
3.5 Installing software updates	21		
3.6 Typical systems.....	21		
CHAPTER 4 PARTS SUPPLIED	23		

4.1 Parts supplied	24	Multiple Radar scanners — location requirements	40
4.2 Inline fuse requirement.....	24	7.4 Radar scanner protection — sailing vessels	41
In-line fuse and thermal breaker ratings.....	24		
CHAPTER 5 PRODUCT DIMENSIONS	26	CHAPTER 8 CABLES AND CONNECTIONS — GENERAL INFORMATION	43
5.1 Product dimensions	27	8.1 Cable types and length.....	44
CHAPTER 6 LOCATION REQUIREMENTS.....	28	8.2 Cable routing	44
6.1 Warnings and cautions	29	8.3 Strain relief.....	44
6.2 Location requirements	29	8.4 Circuit isolation.....	44
Shadow areas and false echoes.....	29	8.5 Cable shielding	44
Radar scanner mounting angle	29	8.6 Suppression ferrites.....	44
Multiple Radar scanners — location requirements	30	8.7 Connections overview.....	45
6.3 Quantum Wi-Fi only installation requirements	30	Typical cable routing scenarios	45
Wi-Fi Signal Reflection	32	Cable routing — platform mount.....	46
Wireless location requirements for optimum performance	33	Cable routing — pole mount	47
Pre-installation site survey — Wi-Fi Analyzer.....	34	Making connections	49
Pre-installation site survey — Raymarine app.....	34		
CHAPTER 7 MOUNTING	36	CHAPTER 9 NETWORK CONNECTIONS.....	50
7.1 Tools required	37	9.1 Network cable connector types	51
7.2 Mounting pre-requisite: "breather" holes	37	9.2 Network connections	51
7.3 Mounting the scanner.....	37	9.3 Network connection — wired (single display).....	51
Multiple Quantum Radar scanners	40	9.4 Network connection — wireless (Wi-Fi).....	52
		9.5 Network connection — wired (multiple displays).....	52
		CHAPTER 10 POWER CONNECTIONS.....	54
		10.1 Power connection	55
		10.2 In-line fuse and thermal breaker ratings	55
		10.3 Grounding not required.....	55

10.4 Power distribution.....	55	Multiple Quantum Radars — more information	65
10.5 Power cable extension (12 / 24 V systems)	57	Retain your Wi-Fi passcode	65
10.6 Grounding not required	57	Wi-Fi troubleshooting.....	66
CHAPTER 11 SYSTEM CHECKS AND TROUBLESHOOTING.....	58	CHAPTER 12 OPERATION	69
11.1 Post installation procedures.....	59	12.1 Operation instructions	70
Mechanical checks.....	59	CHAPTER 13 MAINTENANCE	71
Connecting to a Radar scanner over RayNet.....	59	13.1 Maintenance	72
Powering on a Quantum Radar.....	59	13.2 Unit cleaning instructions	72
Pairing with a Quantum Radar using Wi-Fi	59	CHAPTER 14 TECHNICAL SUPPORT	73
Changing Quantum radar channel	60	14.1 Raymarine product support and servicing.....	74
MFD access point connection when connected to Quantum Wi-Fi.....	61	14.2 Viewing product information.....	75
Standby and sleep modes for Wi-Fi connections.....	61	CHAPTER 15 TECHNICAL SPECIFICATION	76
Retain your Wi-Fi passcode	61	15.1 Conformance specification.....	77
Doppler data source requirements	61	15.2 Physical specification.....	77
Radar target acquisition data source requirements	62	15.3 Power specification.....	77
Bearing alignment	62	15.4 Environmental specification.....	77
Heading alignment.....	62	15.5 Range	77
11.2 Troubleshooting	63	15.6 Transmitter specification	77
Troubleshooting procedure	63	15.7 Receiver specification	78
Doppler troubleshooting.....	65	15.8 Antenna specification	78
		15.9 Doppler specification	78
		CHAPTER 16 SPARES AND ACCESSORIES	79
		16.1 Quantum Radar accessories	80
		16.2 RayNet to RayNet cables and connectors.....	81
		16.3 RayNet to RJ45, and RJ45 (SeaTalkhs) adapter cables	82

APPENDIX A LICENSING ISSUING AUTHORITIES.....85

APPENDIX B ETHERNET (IPV4) NETWORKING
OF RAYMARINE DEVICES WITH THIRD-PARTY
PRODUCTS.....88

CHAPTER 1: IMPORTANT INFORMATION

Safety warnings

Certified Installation

Raymarine recommends certified installation by a Raymarine approved installer. A certified installation qualifies for enhanced product warranty benefits. Contact your Raymarine dealer for further details, and refer to the separate warranty document packed with your product.



Warning: Product installation and operation

- This product must be installed and operated in accordance with the instructions provided. Failure to do so could result in personal injury, damage to your vessel and/or poor product performance.
- Raymarine highly recommends certified installation by a Raymarine approved installer. A certified installation qualifies for enhanced product warranty benefits. Register your warranty on the Raymarine website: www.raymarine.com/warranty



Warning: Potential ignition source

This product is NOT approved for use in hazardous/flammable atmospheres. Do NOT install in a hazardous/flammable atmosphere (such as in an engine room or near fuel tanks).



Warning: Radio frequency radiation hazard

The radar scanner transmits electromagnetic energy at microwave frequencies which can be harmful, particularly to the eyes. Do NOT look at the scanner from close range. Ensure personnel are clear of the scanner when it is powered on.

Radio frequency transmissions can effect cardiac pacemakers and cause damage or cause irregularities in their operation. Any users of such devices should be aware and understand the risks prior to exposure.

Important:

For safety reasons, the radar must be installed above head height, out of range of personnel.



Warning: High voltage

This product contains high voltage. Do NOT remove covers or attempt to access internal components, unless specifically instructed in the documentation provided.



Warning: Switch off power supply

Ensure the vessel's power supply is switched OFF before starting to install this product. Do NOT connect or disconnect equipment with the power switched on, unless instructed in this document.

Product warnings



Warning: Positive ground systems

Do not connect this unit to a system which has positive grounding.



Warning: Power supply voltage

Connecting this product to a voltage supply greater than the specified maximum rating may cause permanent damage to the unit. Refer to the product's information label for the correct voltage.



Warning: Quantum Wi-Fi connection

During installation there will usually be structure that affects the Wi-Fi signal. Before using the Radar for navigation, ensure you test the reliability of your Wi-Fi connection in open waters and away from any other vessels or structure.

Caution: Power supply protection

When installing this product ensure the power source is adequately protected by means of a suitably-rated fuse or thermal circuit breaker.

Caution: Doppler limitations

When the target's speed is more than 60 knots Speed Over Ground (SOG), or the relative speed between your vessel and the target is greater than 120 knots, the direction of target returns from high speed vessels may be displayed incorrectly. Consequently, **the displayed target colors may be inverted, with targets colored red when they should be green, and vice versa.**

Caution: Service and maintenance

This product contains no user serviceable components. Please refer all maintenance and repair to authorized Raymarine dealers. Unauthorized repair may affect your warranty.

Regulatory notices

Transmitted power density levels (from centre of rotation)

- A power density level of 10 W/m² does not occur at any point.

- A power density level of 100 W/m² does not occur at any point.

IEEE statement

IEEE C95.1 – 2005 – Standard for Safety Levels with respect to Human Exposure to Radio Frequency Electromagnetic Fields, 3 kHz to 300 GHz.

ICNIRP Guidelines

When properly installed and operated, the use of this Radar conforms to: ICNIRP Guidelines 1998 - International Commission on Non-Ionising Radiation Protection: Guidelines for limiting exposure to time-varying electric, magnetic and electro-magnetic fields (up to 300 GHz) 1998.

Water ingress

Water ingress disclaimer

Although the waterproof rating capacity of this product meets the stated water ingress protection standard (refer to the product's *Technical Specification*), water intrusion and subsequent equipment failure may occur if the product is subjected to high-pressure washing. Raymarine will not warrant products subjected to high-pressure washing.

Disclaimer

Raymarine does not warrant that this product is error-free or that it is compatible with products manufactured by any person or entity other than Raymarine.

Raymarine is not responsible for damages or injuries caused by your use or inability to use the product, by the interaction of the product with products manufactured by others, or by errors in information utilized by the product supplied by third parties.

Third-party hardware, such as converters, adapters, routers, switches, Access Points etc., provided by third parties, may be made available directly to you by other companies or individuals under separate terms and conditions, including separate fees and charges. Raymarine UK Limited or its affiliates have not tested or screened the third-party hardware.

Raymarine has no control over, and is not responsible for:

- (a) the content and operation of such third-party hardware; or
- (b) the privacy or other practices of such third-party hardware.

The fact that Raymarine's documentation may make reference to such third-party hardware does not indicate any approval or endorsement of any such third-party hardware. Raymarine may reference such third-party hardware only as a convenience.

THIS INFORMATION IS MADE AVAILABLE BY RAYMARINE UK LIMITED ON THE BASIS THAT YOU EXCLUDE TO THE FULLEST EXTENT LAWFULLY PERMITTED ALL LIABILITY WHATSOEVER FOR ANY LOSS OR DAMAGE HOWSOEVER ARISING OUT OF THE USE OF THIS INFORMATION OR RELIANCE UPON THIS INFORMATION.

Raymarine UK Limited does not exclude Raymarine UK Limited's liability (if any) to you for personal injury or death resulting from Raymarine UK Limited's negligence, for fraud or for any matter which it would be illegal to exclude or to attempt to exclude.

EMC installation guidelines

Raymarine® equipment and accessories conform to the appropriate Electromagnetic Compatibility (EMC) regulations, to minimize electromagnetic interference between equipment and minimize the effect such interference could have on the performance of your system.

Correct installation is required to ensure that EMC performance is not compromised.

Note:

In areas of extreme EMC interference, some slight interference may be noticed on the product. Where this occurs the product and the source of the interference should be separated by a greater distance.

For **optimum** EMC performance we recommend that wherever possible:

- Raymarine® equipment and cables connected to it are:
 - At least 1 m (3.3 ft) from any equipment transmitting or cables carrying radio signals e.g. VHF radios, cables and antennas. In the case of SSB radios, the distance should be increased to 2 m (6.6 ft).
 - More than 2 m (6.6 ft) from the path of a radar beam. A radar beam can normally be assumed to spread 20 degrees above and below the radiating element.
- The product is supplied from a separate battery from that used for engine start. This is important to prevent erratic behavior and data loss which can occur if the engine start does not have a separate battery.

- Raymarine® specified cables are used.
- Cables are not cut or extended, unless doing so is detailed in the installation manual.

Note:

Where constraints on the installation prevent any of the above recommendations, always ensure the maximum possible separation between different items of electrical equipment, to provide the best conditions for EMC performance throughout the installation.

Compass safe distance

To prevent potential interference with the vessel's magnetic compasses, ensure an adequate distance is maintained from the product.

When choosing a suitable location for the product you must aim to maintain a distance of at least 1 m (3.3 ft) in all directions from any compasses.

For some smaller vessels it may not be possible to locate the product this far away from a compass. In this situation, when choosing the installation location for your product, ensure that the compass is not affected by the product when it is in a powered on state.

Declaration of Conformity

Raymarine® UK Ltd declares that the radio equipment type **Quantum 2 Doppler** radome radar scanner, part number E70498 / E70498-B, is in compliance with the Radio Equipment Directive 2014/53/EU.

The original Declaration of Conformity certificate may be viewed on the relevant product page at www.raymarine.com/manuals.

Connections to other equipment

Requirement for ferrites on non-Raymarine cables:

If your Raymarine® equipment is to be connected to other equipment using a cable not supplied by Raymarine®, a suppression ferrite **MUST** always be attached to the cable near the Raymarine® unit.

For more information, refer to your third-party cable manufacturer.

Product disposal

Dispose of this product in accordance with the WEEE Directive.

The Waste Electrical and Electronic Equipment (WEEE) Directive requires the recycling of waste electrical and electronic equipment which contains materials, components and substances that may be hazardous and present a risk to human health and the environment when WEEE is not handled correctly.

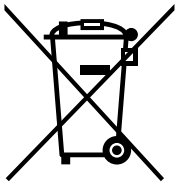

Equipment marked with the crossed-out wheeled bin symbol indicates that the equipment should not be disposed of in unsorted household waste. Local authorities in many regions have established collection schemes under which residents can dispose of waste electrical and electronic equipment at a recycling center or other collection point. For more information about suitable collection points for waste electrical and electronic equipment in your region, refer to the Raymarine website: www.raymarine.com/en-gb/policies/recycling

Open source license agreements

This product is subject to certain open source license agreements. Copies of the license agreements can be found on the Raymarine website: www.raymarine.com/manuals.

Warranty registration

To register your Raymarine product ownership, please visit www.raymarine.com and register online.

It is important that you register your product to receive full warranty benefits. Your unit package includes a bar code label indicating the serial number of the unit. You will need this serial number when registering your product online. You should retain the label for future reference.

IMO and SOLAS

The equipment described within this document is intended for use on leisure marine boats and workboats NOT covered by International Maritime Organization (IMO) and Safety of Life at Sea (SOLAS) Carriage Regulations.

Radar licensing

Installation and operation of this Radar may be subject to individual licensing of the equipment, operator or vessel.

In many countries, the licensing for the use of Radar equipment is included in the **Ship Station license** and **Operator's license** issued for VHF radios.

However, even if you already have a Ship Station license and Operator's license for a VHF radio, **some countries may require a separate license for Radar equipment use.**

Important:

It is your responsibility to determine whether a license is required in your area before operating this equipment.

For a list of license issuing authorities, refer to: [p.85 – Licensing issuing authorities](#)

FCC Notice - Radar

Changes or modifications to this equipment not expressly approved in writing by Raymarine Incorporated could violate compliance with FCC rules and void the operator's authority to operate the equipment.

MSIP Warning Statement for Radio Devices (Korea only)

- 제작자 및 설치자는 해당 무선설비가 전파혼신 가능성이 있으므로 안전 인명과 관련된
- 서비스는 할 수 없음을 사용자 설명서 등을 통하여 운용자 및 사용자에게 충분히 알릴 것
- 법에 의해 전방향 전파 발사 및 동일한 정보를 동시에 여러 곳으로 송신하는 점-대-다지점 서비스에의 사용은 금지되어 있습니다.

Technical accuracy

To the best of our knowledge, the information in this document was correct at the time it was produced. However, Raymarine cannot accept liability for any inaccuracies or omissions it may contain. In addition, our policy of continuous product improvement may change specifications without notice.

As a result, Raymarine cannot accept liability for any differences between the product and this document. Please check the Raymarine website (www.raymarine.com) to ensure you have the most up-to-date version(s) of the documentation for your product.

Operation instructions

For detailed operation instructions for your product, refer to the documentation that accompanies your display.

All product documentation is available to download from the Raymarine website: www.raymarine.com/manuals.

Retain your Wi-Fi passcode

To connect to the Radar using Wi-Fi (wireless), you will need to know the unit's **SSID**, and **Passcode**.

Both the SSID and Passcode are provided on the serial number label on the underside of the unit, and on spare serial number labels supplied in the box. You may wish to make a separate note of this information and keep in a secure location. You should also keep the Radar scanner packaging in a safe place for future reference.

The following information is applicable only to Quantum units running software version 1.62 or later, and Quantum Doppler units running software version 2.43 or later:

In the event that you misplace the SSID and Passcode before the initial pairing, you can power on your Quantum unit and determine the SSID by reviewing all available Wi-Fi networks, using a smartphone, tablet or laptop PC. An unpaired Quantum unit will advertise its SSID periodically in a 10-second cycle. This may take up to 3 minutes.

Once you've obtained the SSID, the next step is to contact Raymarine® product support and servicing, who can then provide you with the passcode associated with your SSID. For further information on how to contact Raymarine® product support and servicing, refer to the following section:

[p.74 — Raymarine product support and servicing](#)

Publication copyright

Copyright ©2023 Raymarine UK Ltd. All rights reserved. No parts of this material may be copied, translated, or transmitted (in any medium) without the prior written permission of Raymarine UK Ltd.



CHAPTER 2: DOCUMENT INFORMATION

CHAPTER CONTENTS

- 2.1 Applicable products — page 15
- 2.2 Document illustrations — page 15
- 2.3 Product documentation — page 15
- 2.4 Operation instructions — page 15

2.1 Applicable products

This document is applicable to the following products:

Product	Description
	(E70498) — <u>Quantum™ 2 Doppler Q24D Radome</u> : Quantum™ 2 Doppler Radar scanner with RayNet and Wi-Fi connections. Supplied with a 10 m power cable.
	(E70498-B) — <u>Black Quantum™ 2 Doppler Q24D Radome</u> : Black Quantum™ 2 Doppler Radar scanner with RayNet and Wi-Fi connections. Supplied with a 10 m power cable.

Special bundle and promotional products

From time to time, Raymarine® may supply certain products as special “bundle”, “package”, or “promotional” variants.

These bundles typically include additional accessories such as cables, and usually have a Txxxxx part number. For these bundle variants, the provided parts supplied and part numbers may differ slightly from those stated in this document. However, the core supplied product and its features will remain the same as those described in this document. To ensure that you are using the correct documentation for your product, please:

- Refer to the product’s core model number, which can be found listed on the label on the rear or underside of your product, or accessed from any Raymarine® multifunction display via the Diagnostics page. Ensure that the number matches one of those listed in the “Applicable products” section of your product documentation.
- Alternatively, contact the place of purchase and request the information. You may need to provide the product’s serial number, which can be found on the product packaging and also on the label on the rear or underside of the unit.

2.2 Document illustrations

Your product and if applicable, its user interface may differ slightly from that shown in the illustrations in this document, depending on product variant and date of manufacture.

All images are provided for illustration purposes only.

2.3 Product documentation

The following documentation is applicable to your product:

Description	Part number
Quantum™ 2 Doppler Radome Installation instructions (this document)	87342
Installation of a Quantum™ 2 Doppler Radar scanner and connection to a wider system of marine electronics.	
Quantum™ Radome Mounting template	87257
Mounting diagram for surface mounting a Quantum™ Radar scanner.	
LightHouse™ 4 Advanced Operation Instructions	81406
Details the operation of the Radar application for multifunction displays running LightHouse™ 4 software.	
LightHouse™ 3 Advanced Operation Instructions	81370
Details the operation of the Radar application for multifunction displays running LightHouse™ 3 software.	

2.4 Operation instructions

For detailed operation instructions for your product, refer to the documentation that accompanies your display.

All product documentation is available to download from the Raymarine website: www.raymarine.com/manuals.

CHAPTER 3: PRODUCT AND SYSTEM OVERVIEW

CHAPTER CONTENTS

- 3.1 Product overview — page 17
- 3.2 Required additional components — page 17
- 3.3 Multifunction display compatibility — page 19
- 3.4 Software updates — page 20
- 3.5 Installing software updates — page 21
- 3.6 Typical systems — page 21

3.1 Product overview

The Quantum™ 2 Doppler Radome is a compact, solid-state Radar scanner, utilizing MARPA technology for target tracking, CHIRP pulse compression for improved range resolution, Doppler technology to make it easier to track moving objects, and Wi-Fi connectivity for easier installation. In conjunction with a compatible multifunction display, the Quantum™ 2 Doppler scanner provides a map-like representation of the area around your vessel, enabling you to identify other vessels, buoys, and land features such as coastlines and hills.

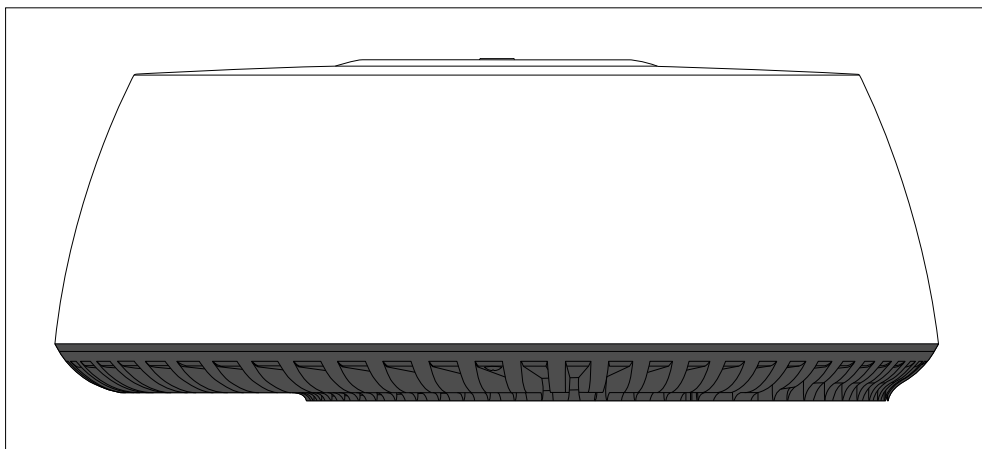

The Quantum™ 2 Doppler Radome has the following features:

- Solid-state technology (no magnetron) for improved efficiency, and rapid start-up.
- Range performance up to 24 nm (dependent on installation location).
- Doppler display, making it easier to track approaching and receding objects.
- MARPA for target tracking (up to 25 targets) and collision avoidance.
- CHIRP pulse compression for improved target range resolution, and reduced background noise.
- Wireless data connection via Wi-Fi, or wired connection via RayNet cable.
- Radar image display and control via Raymarine multifunction display.
- 24 RPM scanner rotation.
- Low power consumption.
- 12 V or 24 V operation.

Product and system overview

- Waterproof to IPx6.

Multiple Quantum Radar scanners

Only 1 (one) Quantum™ Radar scanner can be used at any one time, per networked system.

If you have more than one Quantum™ Radar scanner installed on your vessel and want to use them at the same time, the multifunction displays to which the scanners are connected must NOT be networked together. This applies to Quantum™ scanners connected either wired or wirelessly.

For more information, refer to:

[p.65 – Multiple Quantum Radars – more information](#)

Doppler Radar overview

Doppler Radar technology makes it easier to track moving objects with ground speed exceeding 3 knots.

The Doppler function highlights objects on the Radar display that are moving towards or away from the vessel (e.g. other vessels, but not land or buoys, for example). Stationary targets will not be highlighted.

Doppler Radar technology is particularly beneficial in a marine environment, where poor weather conditions and visibility can make object tracking challenging. With the integration of Doppler information on the Radar display, the process of matching on-screen Radar returns with real-world objects becomes a much simpler task.

Doppler Radar works by transmitting a microwave signal which is then reflected off a moving object at a distance. By analyzing how the object's motion has altered the frequency of the returned signal, the Doppler Radar can interpret the variation to provide highly accurate measurements of an object's direction of travel, relative to the Radar scanner.

3.2 Required additional components

This product forms part of a system of electronics and requires the following additional components for full operation.

- Compatible Raymarine® multifunction display. For a list of compatible multifunction displays, refer to the following section: [p.19 – Compatible multifunction displays](#)

- Optional data cable. The Quantum™ scanner is Wi-Fi-enabled, and can be operated without a fixed data cable. For suitable cables and adaptors for existing cable installations, refer to the following section: [p.79 — Spares and accessories](#)
- Use of the Doppler Radar features requires the following data sources to be available on your system (e.g. connected to your multifunction display, via SeaTalkng® or NMEA 0183). For more information refer to: [p.18 — Doppler data source requirements](#)
- Use of the MARPA Radar features requires the following data sources to be available on your system (e.g. connected to your multifunction display, via SeaTalkng® or NMEA 0183). For more information refer to: [p.18 — Radar target acquisition data source requirements](#)

Doppler data source requirements

Use of the Doppler Radar features requires the following data sources to be available on your system (e.g. connected to your multifunction display, via SeaTalkng® or NMEA 0183).

Required data sources

Data type	Example data source
COG (Course Over Ground)	GPS or GNSS receiver (MFD internal receiver or external receiver).
SOG (Speed Over Ground)	GPS or GNSS receiver (MFD internal receiver or external receiver).

Recommended data source

Data type	Example data source
HDG / HDT (True Heading)	Compass or Autopilot sensor providing Fastheading data (e.g. Evolution EV-1 / EV-2).

Note:

A heading data source is not essential for Doppler operation. However it will improve the performance of Doppler mode at slower speeds (< 15 knots), when tide set and leeway are present.

Radar target acquisition data source requirements

Radar target acquisition requires the following data sources to be available on your system (e.g. connected to your multifunction display, via SeaTalkng® or NMEA 0183).

Data type	Example data source
COG (Course Over Ground)	GPS or GNSS receiver (MFD internal receiver or external receiver).
SOG (Speed Over Ground)	GPS or GNSS receiver (MFD internal receiver or external receiver).
HDG / HDT (True Heading)	Compass or Autopilot sensor providing Fastheading data (e.g. Evolution EV-1 / EV-2).

Retain your Wi-Fi passcode

To connect to the Radar using Wi-Fi (wireless), you will need to know the unit's **SSID**, and **Passcode**.

Both the SSID and Passcode are provided on the serial number label on the underside of the unit, and on spare serial number labels supplied in the box. You may wish to make a separate note of this information and keep in a secure location. You should also keep the Radar scanner packaging in a safe place for future reference.

The following information is applicable only to Quantum units running software version 1.62 or later, and Quantum Doppler units running software version 2.43 or later:

In the event that you misplace the SSID and Passcode before the initial pairing, you can power on your Quantum unit and determine the SSID by reviewing all available Wi-Fi networks, using a smartphone, tablet or laptop PC. An unpaired Quantum unit will advertise its SSID periodically in a 10-second cycle. This may take up to 3 minutes.

Once you've obtained the SSID, the next step is to contact Raymarine® product support and servicing, who can then provide you with the passcode associated with your SSID. For further information on how to contact Raymarine® product support and servicing, refer to the following section: [p.74 — Raymarine product support and servicing](#)

3.3 Multifunction display compatibility

This product must be used in conjunction with a compatible Raymarine® multifunction display / chartplotter.

Compatible multifunction displays

This product is only compatible with the following Raymarine® multifunction displays / chartplotters and software versions:

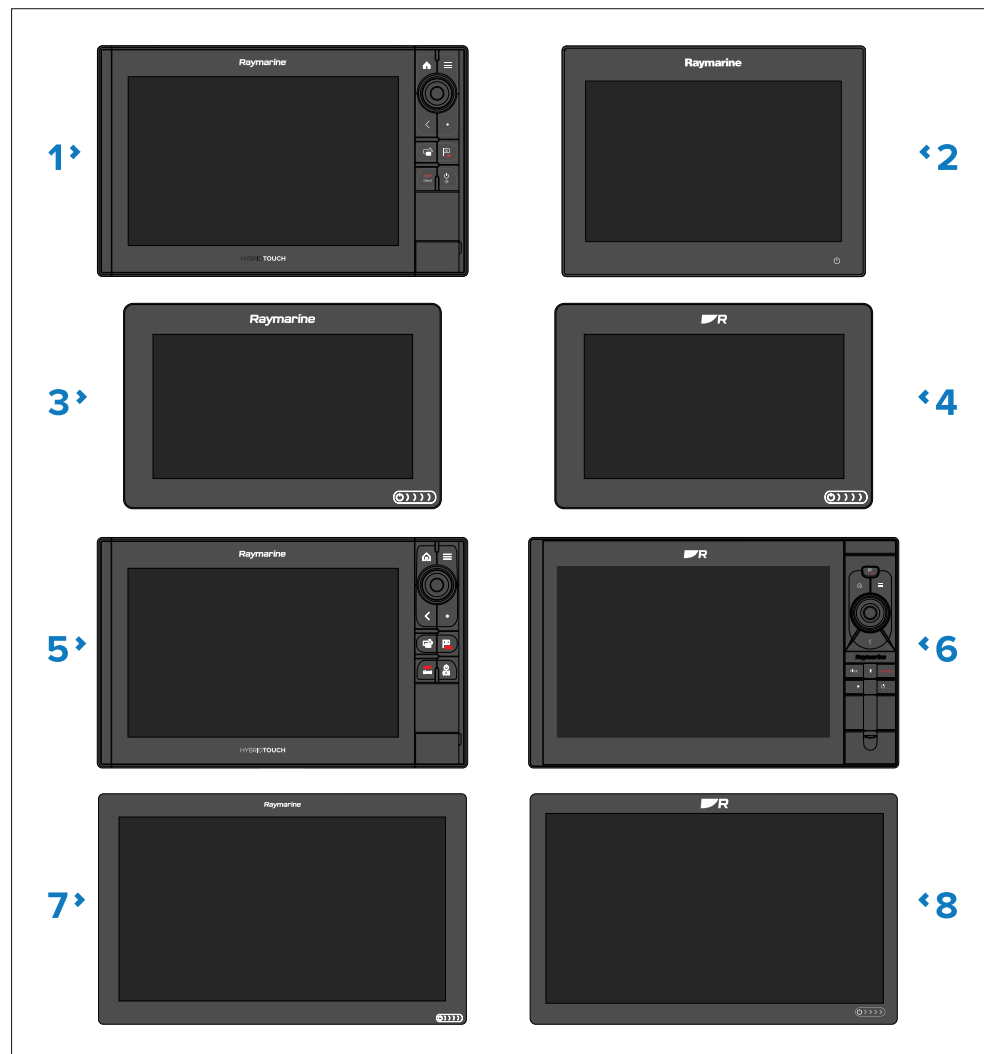

Item	Compatible Raymarine® MFDs	Required MFD software version
1	eS Series eS75, eS77, eS78, eS97, eS98, eS127, eS128	<ul style="list-style-type: none"> • <i>LightHouse 3, versions 3.4 or later</i> • MFDs running existing LightHouse 2 software MUST be upgraded to LightHouse 3, version 3.4 or later
2	gS Series gS95, gS125, gS165, gS195	<ul style="list-style-type: none"> • <i>LightHouse 3, versions 3.4 or later</i> • MFDs running existing LightHouse 2 software MUST be upgraded to LightHouse 3, version 3.4 or later
3	Axiom™ Series: All variants	<ul style="list-style-type: none"> • <i>LightHouse 4, v4.0 or later</i> • <i>LightHouse 3, v3.4 or later</i>
4	Axiom™ + Series: All variants	<ul style="list-style-type: none"> • <i>LightHouse 4, v4.0 or later</i> • <i>LightHouse 3, v3.12 or later</i>
5	Axiom™ Pro Series: 9 RVX, 9 S, 12 RVX, 12 S, 16 RVX, 16 S	<ul style="list-style-type: none"> • <i>LightHouse 4, v4.0 or later</i> • <i>LightHouse 3, v3.4 or later</i>
6	Axiom™ 2 Pro Series: 9 RVM, 9 S, 12 RVM, 12 S, 16 RVM, 16 S	<ul style="list-style-type: none"> • <i>LightHouse 4, v4.3.54 or later</i>
7	Axiom™ XL Series: XL 16, XL 19, XL 22, XL 24	<ul style="list-style-type: none"> • <i>LightHouse 4, v4.0 or later</i> • <i>LightHouse 3, v3.7 or later</i>
8	Axiom™ 2 XL Series: 2 XL 16, 2 XL 19, 2 XL 22, 2 XL 24	<ul style="list-style-type: none"> • <i>LightHouse 4, v4.4.70 or later</i>

Incompatible multifunction displays

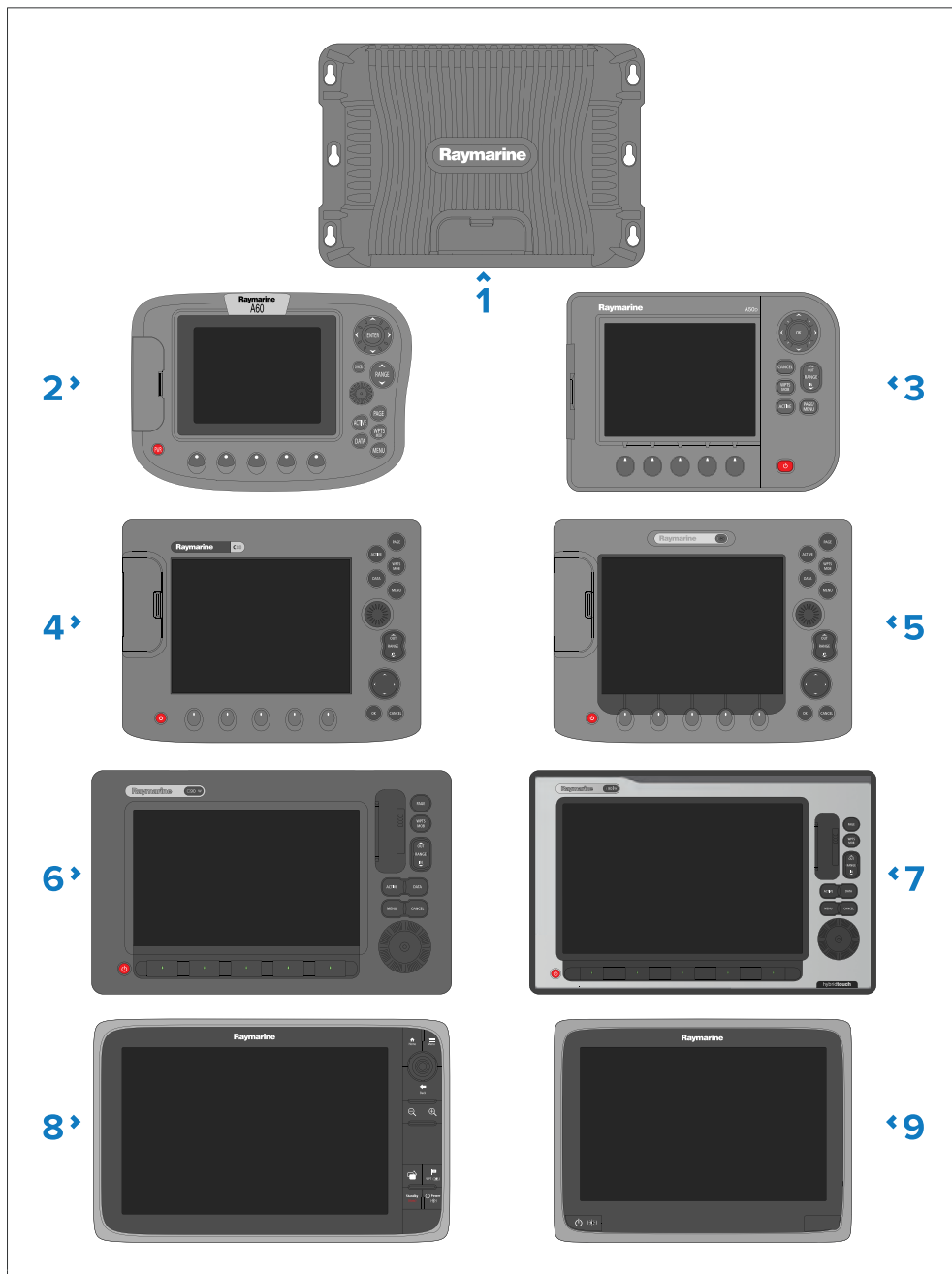

This product is NOT compatible with the following legacy Raymarine® multifunction displays:

Item	Incompatible Raymarine® MFDs
1	G-Series GPM400
2	“Classic” A-Series A60, A65
3	“Classic” A-Series A50, A50D, A57D, A70, A70D
4	“Classic” C-Series C70, C80, C120
5	“Classic” E-Series E80, E120
6	C-Series Widescreen C90W, C120W, C140W
7	E-Series Widescreen E90W, E120W, E140W
8	“New” c Series c95, c97, c125, c127 “New” e Series e7, e7D, e95, e97, e125, e127, e165
9	“New” a Series a65, a67, a68, a75, a77, a78, a95, a97, a98, a125, a127, a128

3.4 Software updates

Raymarine® regularly issues software updates for its products which provide new and enhanced features and improved performance and usability. It’s important to ensure that you have the latest software for your products by regularly checking the Raymarine® website for new software releases.

To check for the latest software updates and the software update procedure for your specific product(s) refer to: www.raymarine.com/software

Unless otherwise stated, software updates for Raymarine products are performed using a Raymarine MFD/chartplotter.

- Where applicable, you should always backup your user data and settings before performing a software update.
- To update SeaTalkng® products you must use the datamaster MFD/Chartplotter which is physically connected to the SeaTalkng® backbone.
- Ethernet (RayNet) products can be updated from any MFD/Chartplotter on the same network as the product to be updated.
- In order to perform a software update any connected Autopilot or Radar must be switched to Standby.
- The MFD's/Chartplotter's "Check online" feature is only available when the MFD has an Internet connection.

Note:

If in doubt as to the correct procedure for updating your product software, refer to your dealer or Raymarine® technical support.

3.5 Installing software updates

Short desc is not printed, but is used in searches

- The software update process is carried out at your own risk. Before initiating the update process ensure you have backed up any important files.
- Ensure that the product(s) has a reliable power supply and that the update process is not interrupted.
- Damage caused by an incomplete update is not covered by Raymarine warranty.
- By downloading the software update package, you agree to these terms.

3.6 Typical systems

The following illustrations show the various products that can be connected in a typical system.

These systems are shown as an **example only**, and may differ from your planned installation. For information on available cables and accessories, refer to: [p.79 — Spares and accessories](#)

Example: basic Radar system (wired data connection)

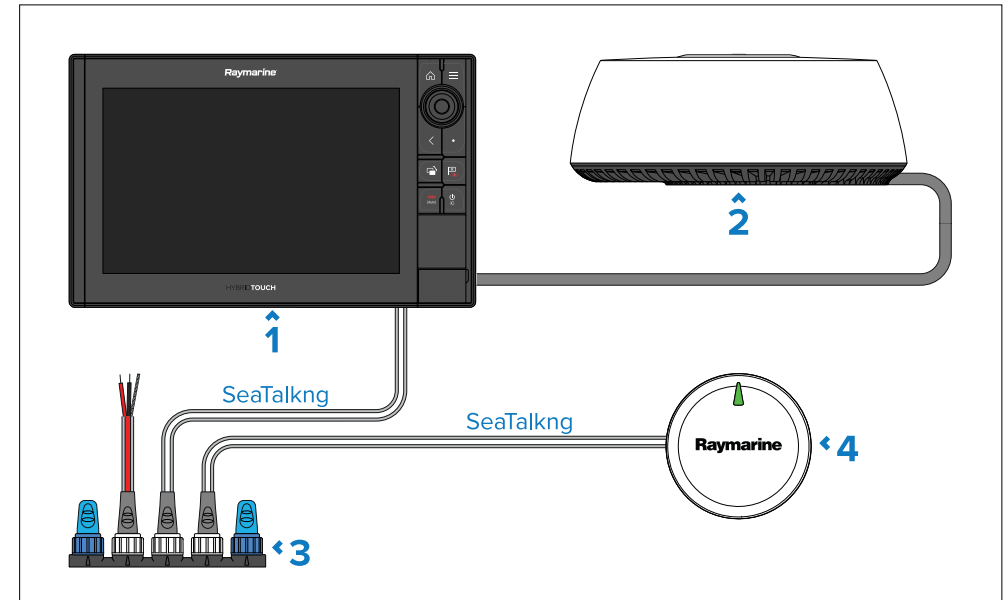

Note:

Power connections are not shown in the above illustration. The MFD, Quantum, and SeaTalkng® bus each require their own dedicated power supplies. For more information, refer to the *Installation instructions* for each respective product.

1. Multifunction display (MFD) / chartplotter.
2. Quantum™ 2 Doppler Radome.
3. SeaTalkng® bus (e.g. 5-way conector or backbone).
4. Evolution EV-1 / EV-2 (required for Doppler and MARPA features).

Example: basic Radar system (wireless data connection)

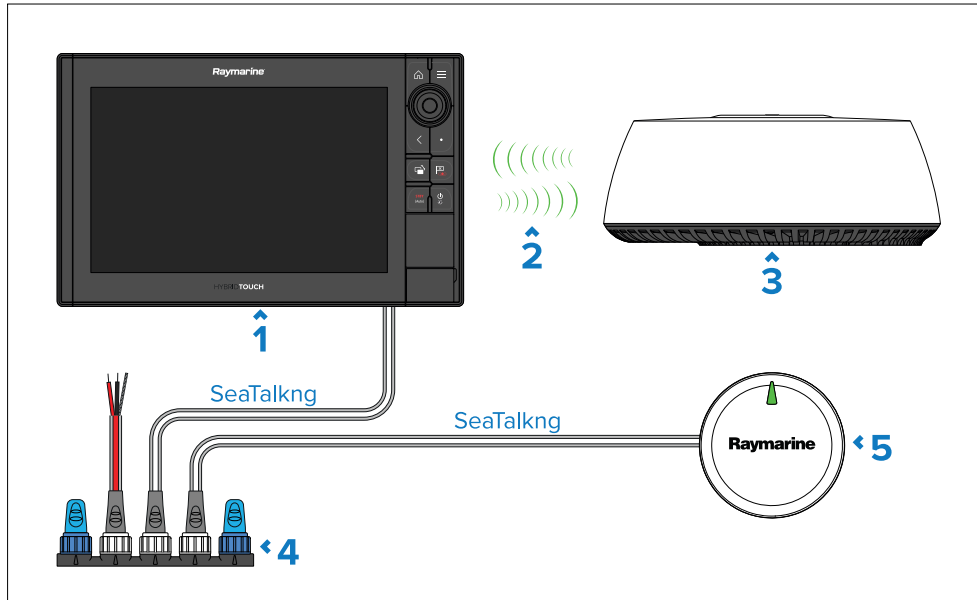

Note:

Power connections are not shown in the above illustration. The MFD, Quantum, and SeaTalkng® bus each require their own dedicated power supplies. For more information, refer to the *Installation instructions* for each respective product.

1. Multifunction display.
2. Wi-Fi data link between Quantum and MFD.
3. Quantum™ 2 Doppler Radome.
4. SeaTalkng® bus (e.g. 5-way connector or backbone).
5. Evolution EV-1 / EV-2 (required for Doppler and MARPA features).

CHAPTER 4: PARTS SUPPLIED

CHAPTER CONTENTS

- 4.1 Parts supplied — page 24
- 4.2 Inline fuse requirement — page 24

4.1 Parts supplied

The following items are supplied with your product.

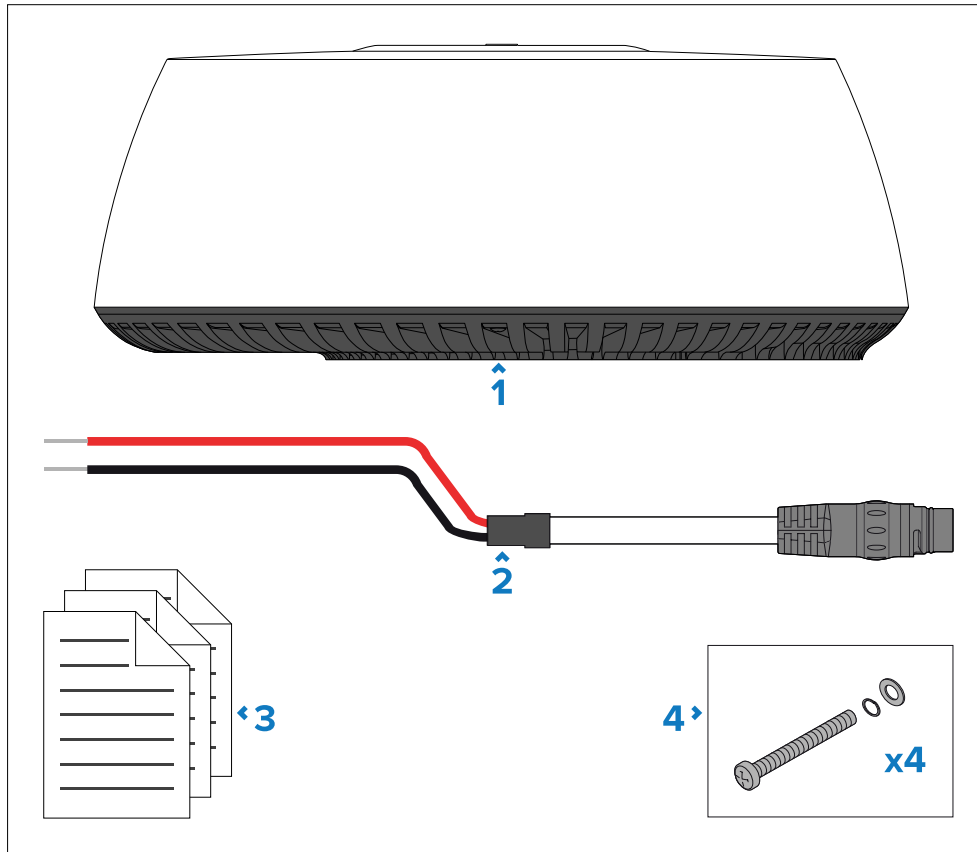

Item	Description
1	Quantum™ Radome.
2	Power cable 10 m (32.8 ft.).
3	Documentation.
4	Mounting fixings: 4x M8 bolts, 4x spring washers, 4x flat washers.

Note:

The list of parts supplied with your Quantum™ variant may differ slightly from the list provided here. Please be aware that, from time to time, Raymarine® may supply certain products as special “bundle”, “package”, or “promotional” variants, which may contain different accessories compared to the core product variants described in this document. Refer to the following section for more information: [p.15 — Special bundle and promotional products](#)

4.2 Inline fuse requirement

Your product requires a suitably-rated inline fuse to be fitted to the red power wire, housed in a waterproof fuse holder.

This fuse and its fuse holder are **NOT supplied** with your product, and must be obtained separately, from a marine or electrical retailer.

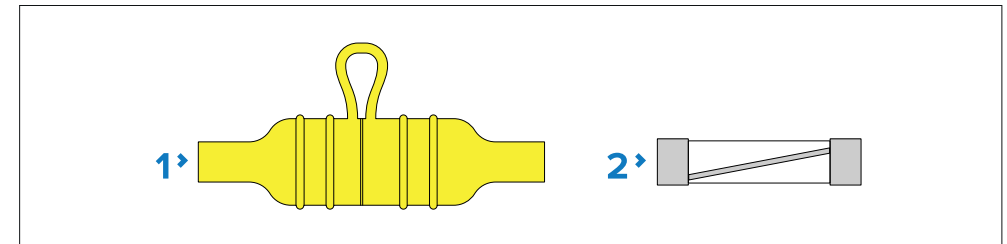

1. Waterproof fuse holder.
2. Suitably-rated inline fuse.

Fuse ratings:

- Voltage rating — must be equal to or greater than the voltage of your vessel’s power supply.
- Current rating — refer to the *Inline fuse and thermal breaker rating* section listed below.

In-line fuse and thermal breaker ratings

The following in-line fuse and thermal breaker ratings apply to your product:

In-line fuse rating	Thermal breaker rating
5 A	3 A

Note:

- The suitable fuse rating for the thermal breaker is dependent on the number of devices you are connecting. If in doubt consult an authorized Raymarine® dealer.
- Your product's power cable may have an in-line fuse fitted, if not then you must add an in-line fuse / breaker to the positive wire of your product's power connection.

CHAPTER 5: PRODUCT DIMENSIONS

CHAPTER CONTENTS

- [5.1 Product dimensions — page 27](#)

5.1 Product dimensions

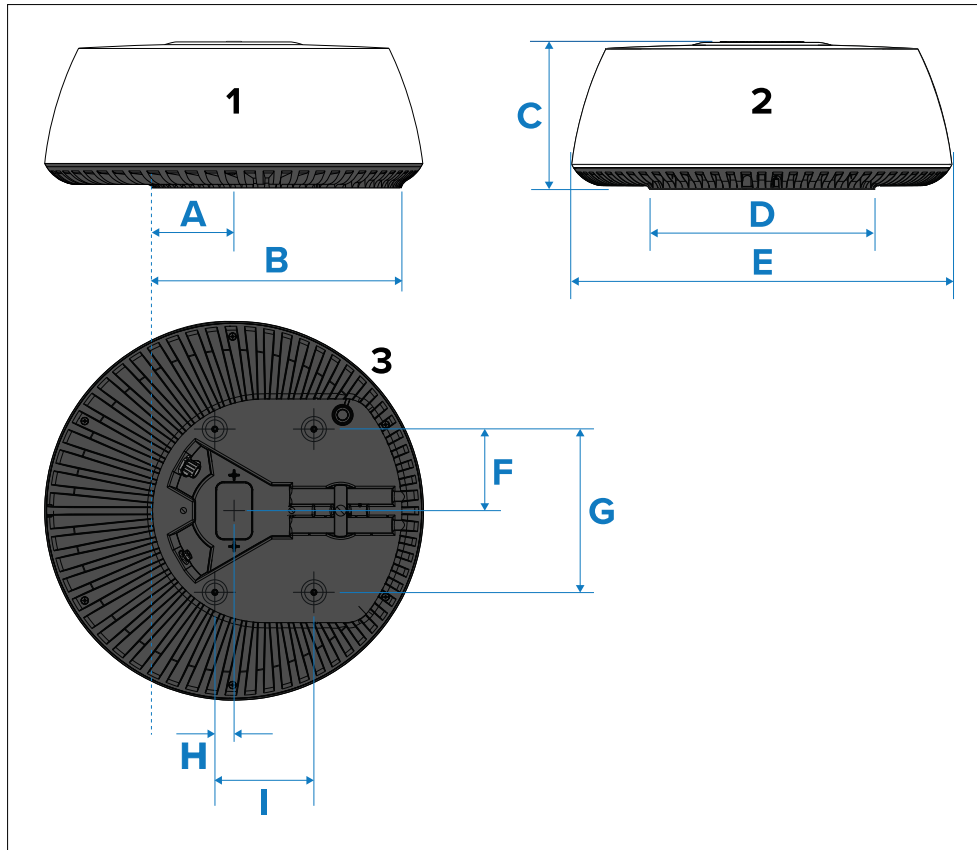

1. Side view of Radar scanner.
2. Rear view of Radar scanner.
3. Underside view of Radar scanner.

Dimension	Description
E = 541.0 mm (21.30 in.)	Width of Radar scanner.
F = 116.5 mm (4.59 in.)	Distance from centerline to rear mounting hole.
G = 233.0 mm (9.17 in.)	Distance between mounting holes.
H = 27.5 mm (1.08 in.)	Distance from centerline to front mounting hole.
I = 141.5 mm (5.57 in.)	Distance between front and rear mounting holes.

Dimension	Description
A = 116.0 mm (4.57 in.)	Distance from centerline of scanner to front of mounting base.
B = 355.0 mm (13.98 in.)	Distance from rear of mounting base to front of mounting base.
C = 209.5 mm (8.25 in.)	Height of Radar scanner.
D = 319.5 mm (12.58 in.)	Mounting base width (rear of unit).

CHAPTER 6: LOCATION REQUIREMENTS

CHAPTER CONTENTS

- 6.1 Warnings and cautions — page 29
- 6.2 Location requirements — page 29
- 6.3 Quantum Wi-Fi only installation requirements — page 30

6.1 Warnings and cautions

Important:

Before proceeding, ensure that you have read and understood the warnings and cautions provided in the following section of this document:
[p.9 – Important information](#)

6.2 Location requirements

The optimum height for the Quantum™ scanner is a location that is high enough above the waterline to give a long range line-of-sight to the horizon, but not so high as to be adversely affected by the vessel's pitching and rolling.

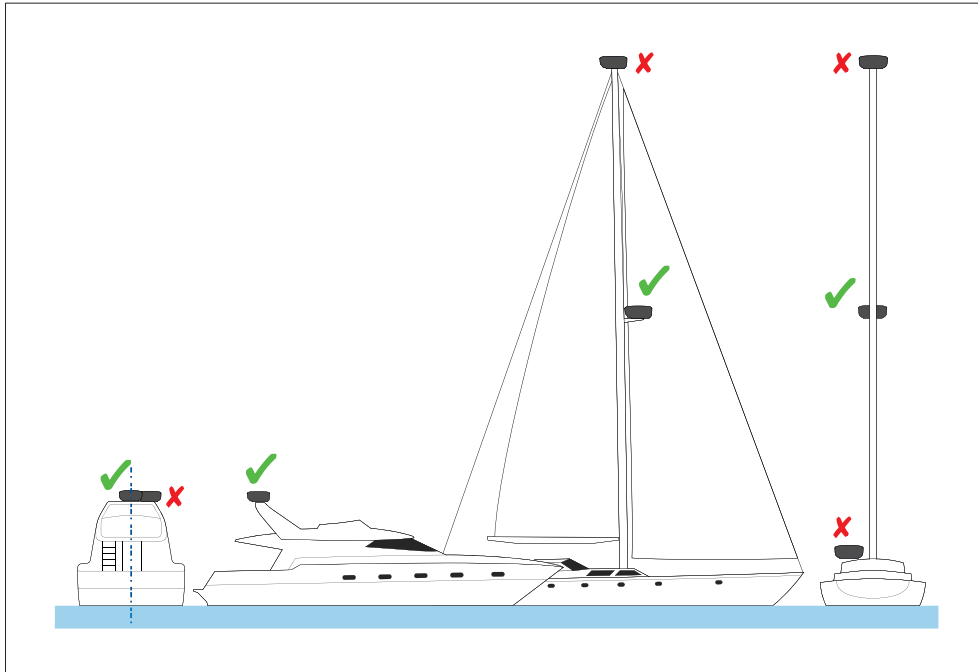

The scanner must also be mounted where it is:

- Above head height.
- Easily accessible.
- As near as possible to the vessel's centerline.

[Location requirements](#)

- On a rigid and stable platform, capable of securely supporting the scanner under seagoing conditions.
- Clear of large objects such as the flybridge, large engine stacks, searchlights, horns, masts, etc. For additional information, see: [p.29 – Shadow areas and false echoes](#)
- Clear of heat and fumes.
- At least 1 m (3 ft) from a magnetic compass or other scanners.

Shadow areas and false echoes

Mount the Radar scanner away from large structures or equipment, such as engine stacks, searchlights, horns, or masts. These objects may cause shadow areas and false echoes. For example, if you mount the Radar scanner on a mast, echoes from other targets may be reflected from the mast. Wet sails may also cause shadow areas, so Radar performance may be reduced in the rain. It is particularly important to avoid shadow areas near the bow. Raising or even lowering the Radar scanner may help to reduce these effects.

In shadow areas beyond the obstruction there will be a reduction of the beam intensity. There may be a blind sector if the beam intensity is not sufficient to obtain an echo from an object. This may occur even at close range. For this reason the angular width and relative bearing of any shadow area must be determined at installation.

You may be able to detect shadow areas or false echoes on your multifunction display. For example, sea clutter can be used as a good indicator of blind arcs. Dark sectors on the Radar display indicate possible shadowed areas. This information should be posted near the display unit and operators must be alert for targets in these blind areas.

Radar scanner mounting angle

Ensure the Radar scanner rotates parallel to the water line.

The Radar beam from the Radar scanner is approximately 20° wide in the vertical direction, to give good target detection even when your vessel pitches and rolls.

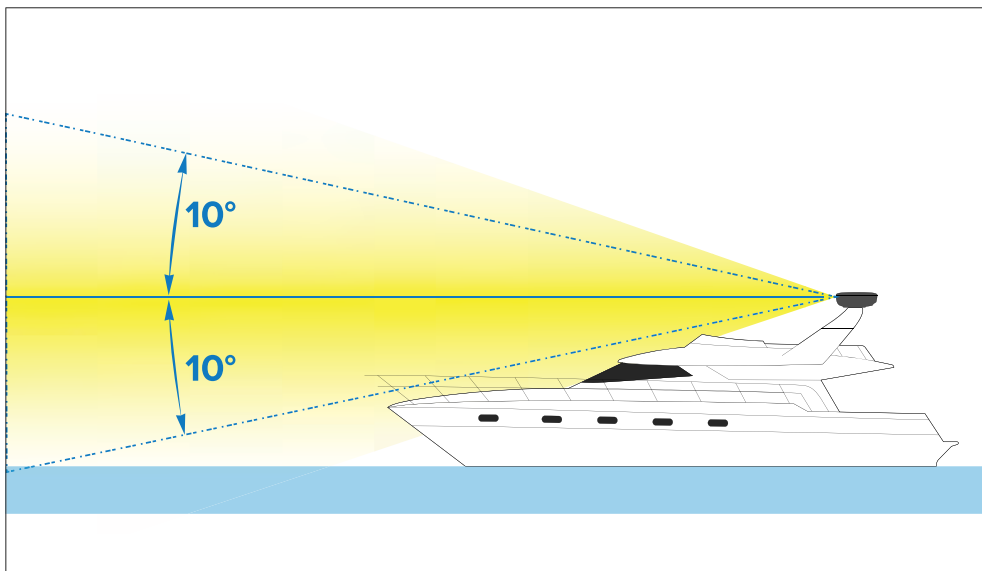

Planing hull vessels, and some displacement hull vessels, adopt a higher bow angle when the vessel is at cruising speed. This may raise the Radar's main radiation angle, and can cause poor detection of nearby targets. It may be necessary to compensate for the bow rise to ensure optimum target detection. This can be achieved by fitting a wedge or washers between the mounting platform and the base of the Radar scanner, so that the Radar beam remains parallel to the water line when the vessel's bow rises at cruising speed.

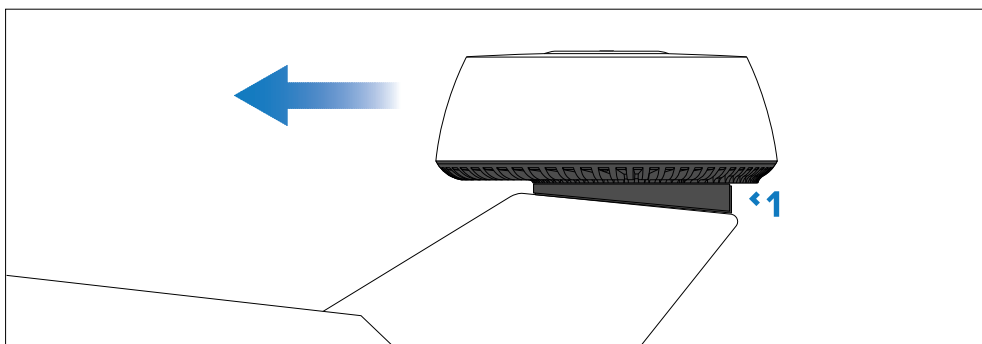

1. Wedge or washers

Multiple Radar scanners — location requirements

Important location considerations when installing multiple radar scanners on the same vessel.

- Scanners should be mounted above each other, vertically separated by at least 0.5 m (1.6 ft). This applies to all installation locations on the vessel.
- Multiple scanners should be mounted in a way that minimizes interference between the vertical beamwidths of the 2 scanners.
- In all cases, you should aim to achieve as much physical separation as possible, to minimize any potential interference.

6.3 Quantum Wi-Fi only installation requirements

Whilst the Wi-Fi performance has been tested and proven in many different installation scenarios, the requirements below must be taken into consideration before choosing a location for the Quantum™ Radar.

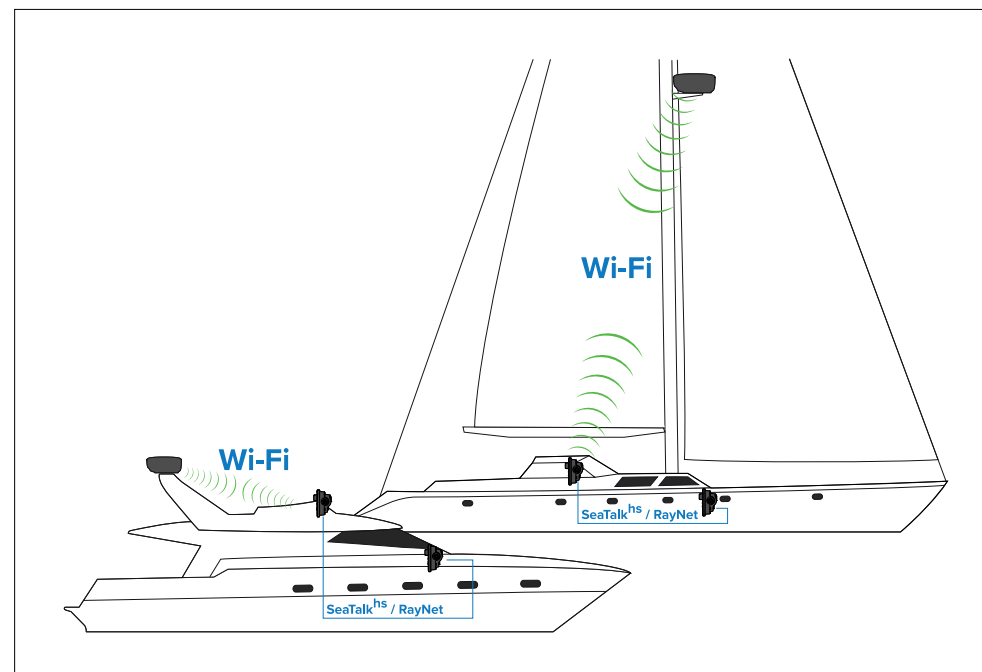

In systems with multiple MFDs, the Radar should be connected to the MFDs that are located closest to it, or to the MFDs with the clearest line of sight to the Radar.

The maximum distance between MFD and Radar will vary depending on the installation environment (i.e. obstructions and interference).

Example 1 — Open air, line-of-sight in optimum conditions

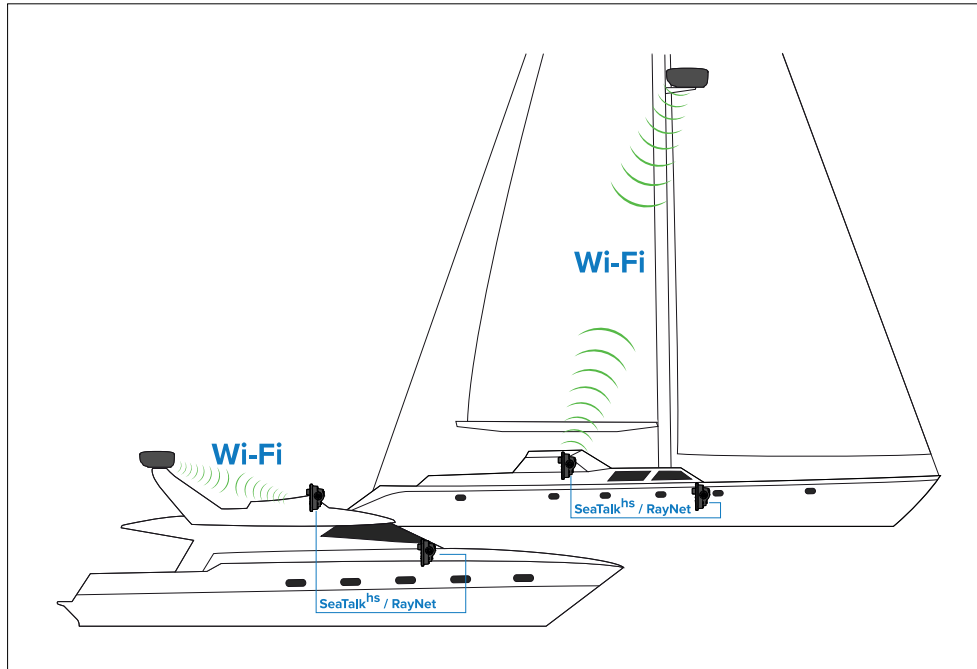

In optimum open air, clear line-of-sight conditions a reliable connection is possible at distances up to 100 m (328 ft). However, there are many factors that can influence this, so a pre-installation site survey should always be performed. For reliable Wi-Fi performance the signal strength should be better than -75dBm . The closer the signal is to zero the better the Wi-Fi performance will be (e.g. -40dBm is better than -75dBm). You can assess the potential signal strength at the desired location during the Pre-installation Site Survey using a Wi-Fi Analyzer app on your smart device.

Example 2 — Signal passing through Fiberglass coach roof

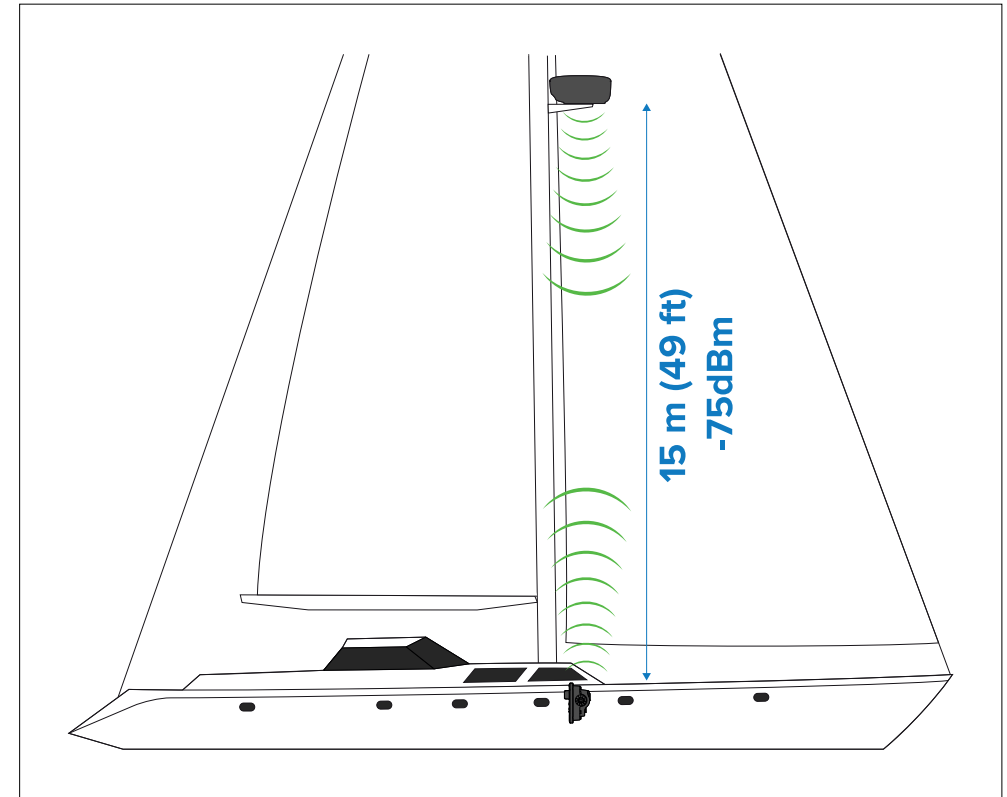

In the example above the maximum distance with acceptable Wi-Fi performance is 15 m (49 ft), due to the heavy fiberglass coach roof that the signal has to pass through.

Example 3 — Signal passing through heavy structure

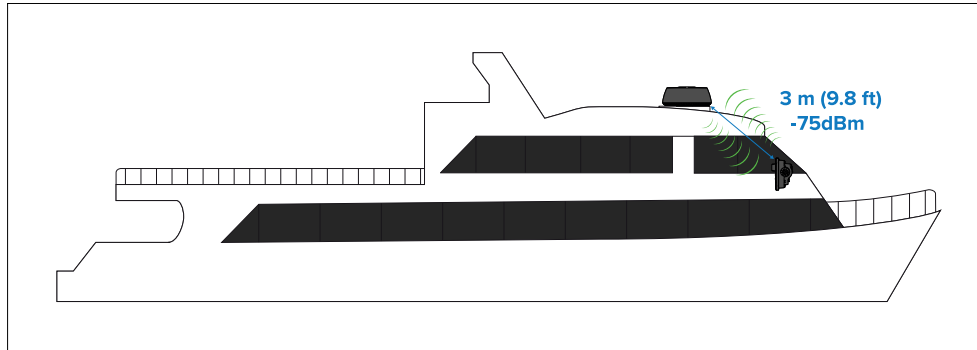

In the example above the maximum distance with acceptable Wi-Fi performance is 3 m (9.8 ft), due to the metal roof that the signal has to pass through.

Obstacles in the direct line of sight between the Radar and MFD will further impact Wi-Fi Performance. The impact of each obstacle is usually minimal, however the effect is cumulative. Obstacles can include but are not limited to:

- **Vessel structure** — Where the Wi-Fi signal passes through a vessel bulkhead or a coach roof, the Wi-Fi performance will be impacted. Depending on the material and thickness of the structure the impact may be severe; for example, a thick steel bulkhead may completely block the Wi-Fi signal.
- **Radar mounting** — The type of installation can impact performance; for example, mounting on a solid steel platform will have a greater impact on performance than mounting on a bar-style mount.
- **Electrical equipment and other objects** — Any object in the direct line-of-sight between the Radar and MFD can impact Wi-Fi performance. Electrical, electronic and electromagnetic devices will have a greater impact than furniture.
- **MFD installation** — MFD installation can also impact Wi-Fi performance; for example, if the MFD is surface mounted in a steel construction dash, the Wi-Fi performance will be impacted.

Wi-Fi Signal Reflection

When establishing a location for your Quantum Radar, that will be connected using a Wi-Fi connection, it is important to consider the effects your surroundings can have on the Wi-Fi signal. The Wi-Fi signal will reflect or

‘bounce’ off nearby objects which may create an easier path for the signal to take, whilst your connection may appear reliable it may quickly degrade when you take your vessel out into open water.

Example

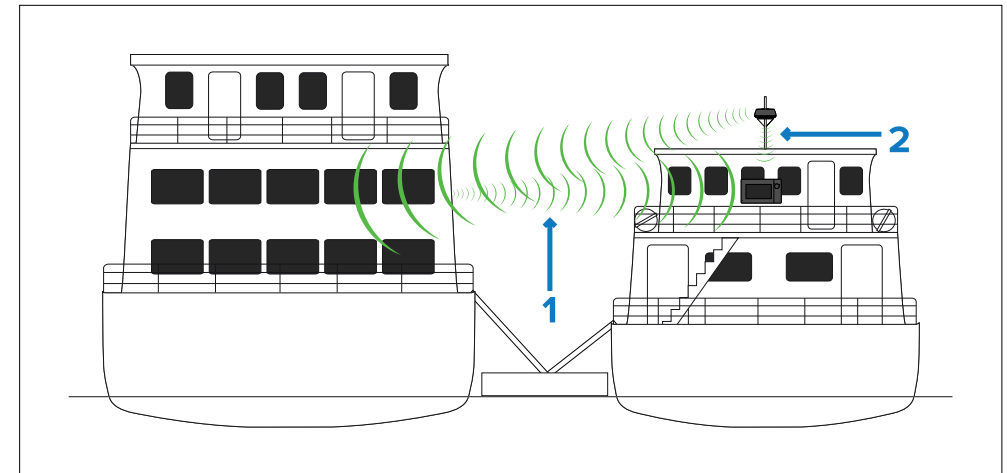

1. In this example the Wi-Fi signal is bounced off a nearby vessel and back through the windows on the bridge, this provides an easier path than passing through the metal roof.
2. In this example the Wi-Fi signal is reduced when passing through the metal roof. This, however may be the only path the signal can take when out in open water.

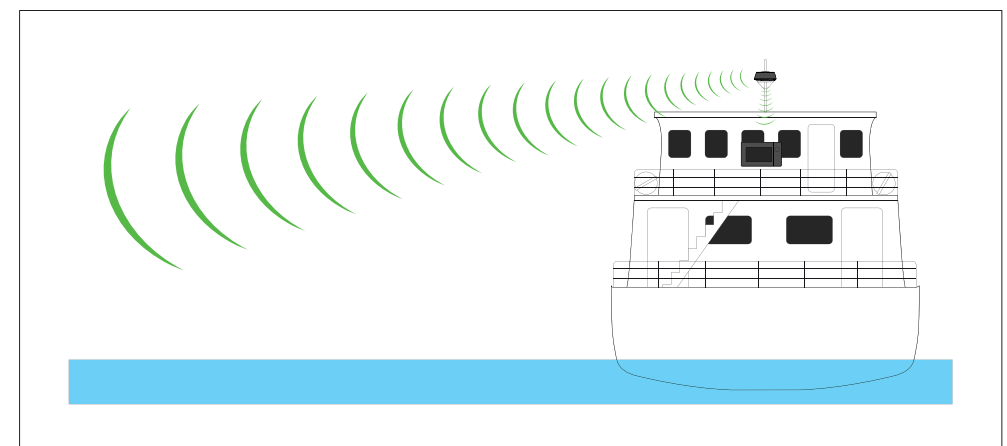



Warning: Quantum Wi-Fi connection

During installation there will usually be structure that affects the Wi-Fi signal. Before using the Radar for navigation, ensure you test the reliability of your Wi-Fi connection in open waters and away from any other vessels or structure.

Wireless location requirements for optimum performance

All wireless devices in your system must be located in such a way that they can reliably receive and/or transmit wireless signals.

A number of factors can influence wireless performance. For example, physical obstacles and certain vessel structures and materials can all negatively impact wireless performance. Therefore, **it's important to check a product's wireless performance at the desired installation location before drilling any mounting holes.**

Vessel construction and materials

Wherever possible, mount products on surfaces constructed from GRP (e.g. fiberglass resin, or foam), or on dry wooden bulkheads.

Conductive materials in the signal path can have a significant impact on wireless signal performance. Reflective surfaces such as metal surfaces, some types of glass and even mirrors can drastically affect performance or even block the wireless signal. Installation locations that are in close proximity to these materials should be avoided. **Do NOT mount wireless products directly to conductive materials.** This includes any mounting surface or enclosure/pod.

Examples of conductive materials include, but are not limited to:

- carbon fibre, kevlar, or aramid (including sails made from these materials)
- aluminium
- steel

In installations with conductive materials, if available, mount the wireless product using an accessory pole mount or deck mounting kit. A clearance of at least 10 cm (3.9 in) is required to minimize the ground effect from conductive materials. This applies to transmitters as well as displays. If moving the product fixes the problem, consider cutting an antenna clearance hole behind the unit (once the product position and mounting have been finalized).

Wireless performance can also be degraded in locations where the wireless signal passes through a bulkhead containing power cables.

Crew members (especially when wet) can also be obstructive to wireless signals, if their bodies pass through the signal area between wireless sensor and any associated displays.

Checking and optimizing signal strength

It may be necessary to experiment with the location of your wireless products to achieve optimal wireless performance and a clear signal path.

The distance between wireless products should always be kept to a minimum. Do not exceed the maximum stated range of your wireless product (maximum range will vary for each device).

Wireless performance degrades over distance, so products farther away will receive less network bandwidth. Products installed close to their maximum wireless range may experience slow connection speeds, signal dropouts, or not being able to connect at all.

For best results, the wireless product should have a clear, direct line-of-sight to the product it will be connected to. Any physical obstructions can degrade or even block the wireless signal.

Some wireless products feature a signal strength indicator to assist in the process of determining the location with the best wireless performance. Choose the location with the highest and most consistently strong direct signal reading, during a 5 minute monitoring period. Try alternative locations for the transmitter to maximise the signal strength to the displays; e.g. try locations below a hatch or skylight or near to a window. A small change in product position can result in a significant change in the signal strength.

Note:

Some wireless products (e.g. a Hull Transmitter) will not transmit data unless a transducer is connected. Also consider that an NMEA or SeaTalkng product (e.g. an interface) will not transmit data unless an appropriate data source is connected.

Interference and other equipment

Interference from other people's wireless devices can cause interference with your products. You can use a third-party wireless analyzer tool / smartphone app to assess the best wireless channel to use (e.g. a channel not in use or one used by the least number of devices).

Wireless products should be installed at least 1 m (3 ft) away from:

- Other wireless-enabled products
- Transmitting products that send wireless signals in the same frequency range
- Other electrical, electronic or electromagnetic equipment that may generate interference.

Software updates

It's also important to ensure all your wireless products are running the latest software versions, as improvements are made over time to wireless performance.

Pre-installation site survey – Wi-Fi Analyzer

Before installing a Quantum Radar, that will be connected using Wi-Fi, a site survey should be performed to ensure the Wi-Fi Signal strength is sufficient to maintain a reliable connection.

It is recommended that you perform the site survey using a smart device and a Wi-Fi Analyzer app (e.g. Wi-Fi Analyzer by Farproc for android devices).

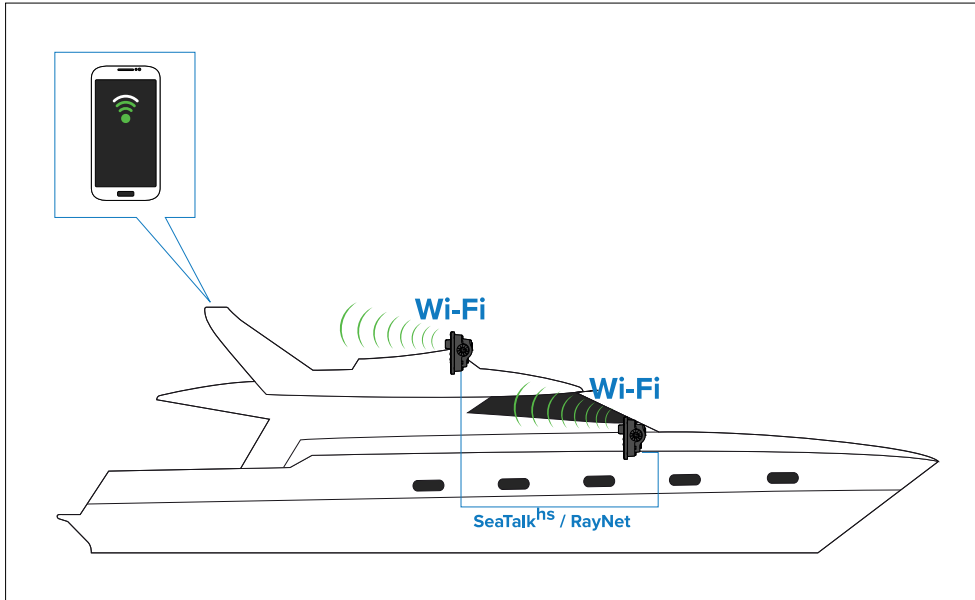

1. Install the Wi-Fi Analyzer app on your smart device.
2. Enable your MFDs Wi-Fi connection: ([Homescreen > Set-up > Wireless connection > Wi-Fi > Wi-Fi: On])

3. Make a note of the MFDs Wi-Fi Name ([Homescreen > Set-up > Wireless connection > Wi-Fi > Wi-Fi Sharing > Wi-Fi Name]).
4. Go to the location you have chosen for your Radar.
5. Open the Wi-Fi Analyzer app on your smart device and scan available networks.
6. Establish the signal strength of your MFDs Wi-Fi network at the intended install location.

For reliable Wi-Fi performance the signal strength should be better than -75dBm , the closer the signal is to zero the better the Wi-Fi performance will be (e.g. -40dBm is better than -75dBm).

7. If you have a weak or intermittent signal then you will need to investigate further, please refer to the Wi-Fi location requirements guide to help establish what may be causing the problem.
8. For networks with multiple MFDs, repeat steps 2 to 7 for each MFD in your network.

Pre-installation site survey – Raymarine app

You can also use Raymarine apps such as RayControl or RayView to assess the reliability of the Wi-Fi connection at the desired installation location.

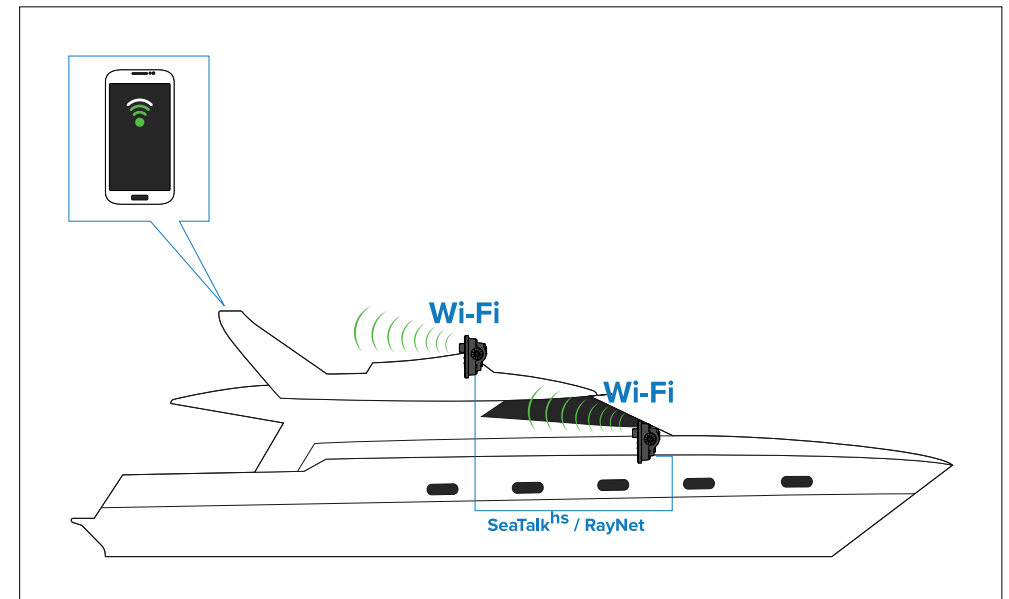

1. Enable your MFDs Wi-Fi connection: ([Homescreen > Set-up > Wireless connection > Wi-Fi > Wi-Fi: On])
2. Enable 'Viewing only' or 'Remote control' from the Mobile apps menu: ([Homescreen > Set-up > Wireless connection > Wi-Fi > Wi-Fi Sharing > Mobile apps]).
3. Make a note of the MFDs Wi-Fi Name ([Homescreen > Set-up > Wireless connection > Wi-Fi > Wi-Fi Sharing > Wi-Fi Name]).
4. Go to the location you have chosen for your Radar.
5. Using your smart device, search for available Wi-Fi networks.
6. Find your MFDs network and check the signal strength reported by your device.
7. If you have a strong signal strength, open a Raymarine mobile app such as RayView or RayControl and check functionality at the desired location. If you do not experience any performance issues running the app then you can proceed with the installation.
8. If you have a weak or intermittent signal then you will need to investigate further, please refer to the Wi-Fi location requirements guide to help establish what may be causing the problem.
9. For networks with multiple MFDs, repeat steps 1 to 9 for each MFD in your network.

- **1/4** — Unable to maintain a connection, usually accompanied by very poor connection speed (**LightHouse™** MFD: -150dBm or worse).
- **2/4** — Intermittent disconnects and reconnects, usually accompanied by a slow connection speed (**LightHouse™** MFD: -80dBm to -149dBm).
- **3/4** — Reliable connection with good connection speed (**LightHouse™** MFD: -70dBm to -79dBm).
- **4/4** — Reliable connection, excellent connection speed (**LightHouse™** MFD: -55dBm or better).

Wi-Fi signal strength

Wi-Fi signal strength is measured in decibel-milliwatts (dBm). The signal strength of the network you are currently connected to is usually represented graphically by a Wi-Fi symbol.

The signal strength range represented by each filled bar is determined independently by each device manufacturer. However, in general the performance will be similar.

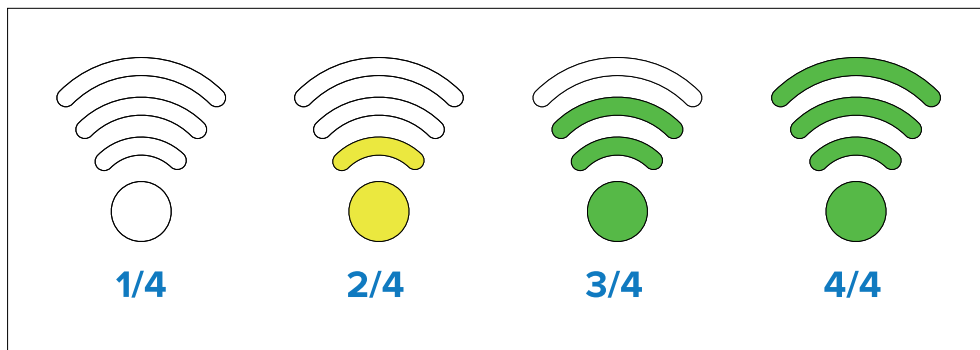

CHAPTER 7: MOUNTING

CHAPTER CONTENTS

- 7.1 Tools required — page 37
- 7.2 Mounting pre-requisite: "breather" holes — page 37
- 7.3 Mounting the scanner — page 37
- 7.4 Radar scanner protection — sailing vessels — page 41

7.1 Tools required

Product installation requires the following tools:

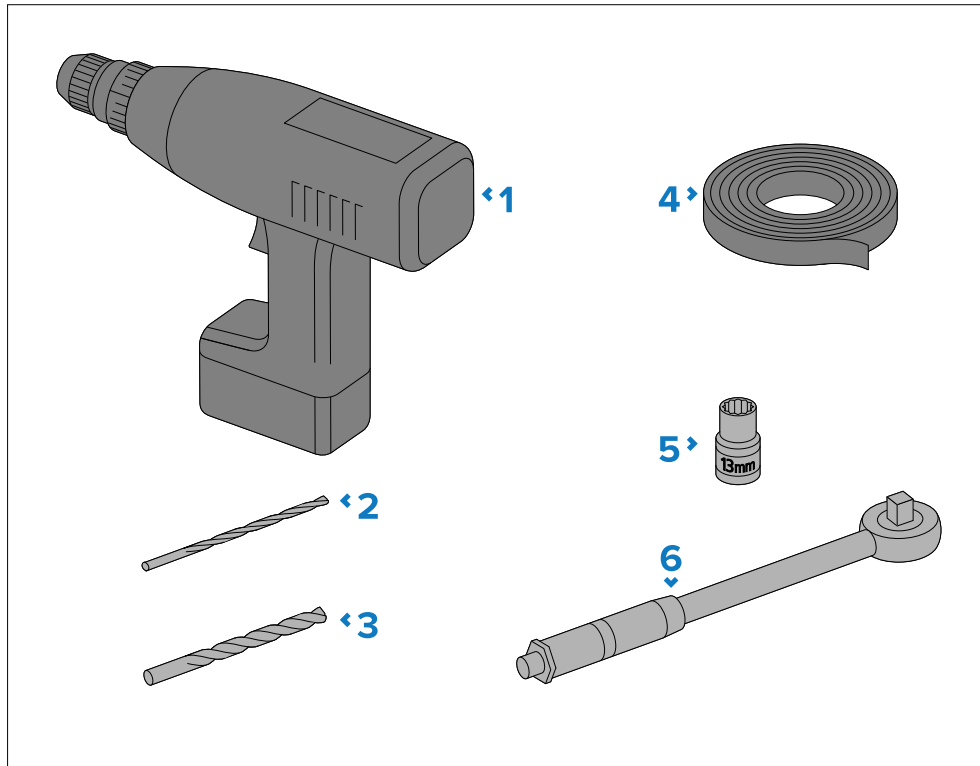

1. Power drill
2. 3 mm drill bit
3. 10 mm drill bit
4. Adhesive tape
5. 13 mm socket
6. Torque wrench

7.2 Mounting pre-requisite: "breather" holes

The base of the unit features a "breather", a series of small holes which allow air to circulate between the underside of the unit and the mounting surface.

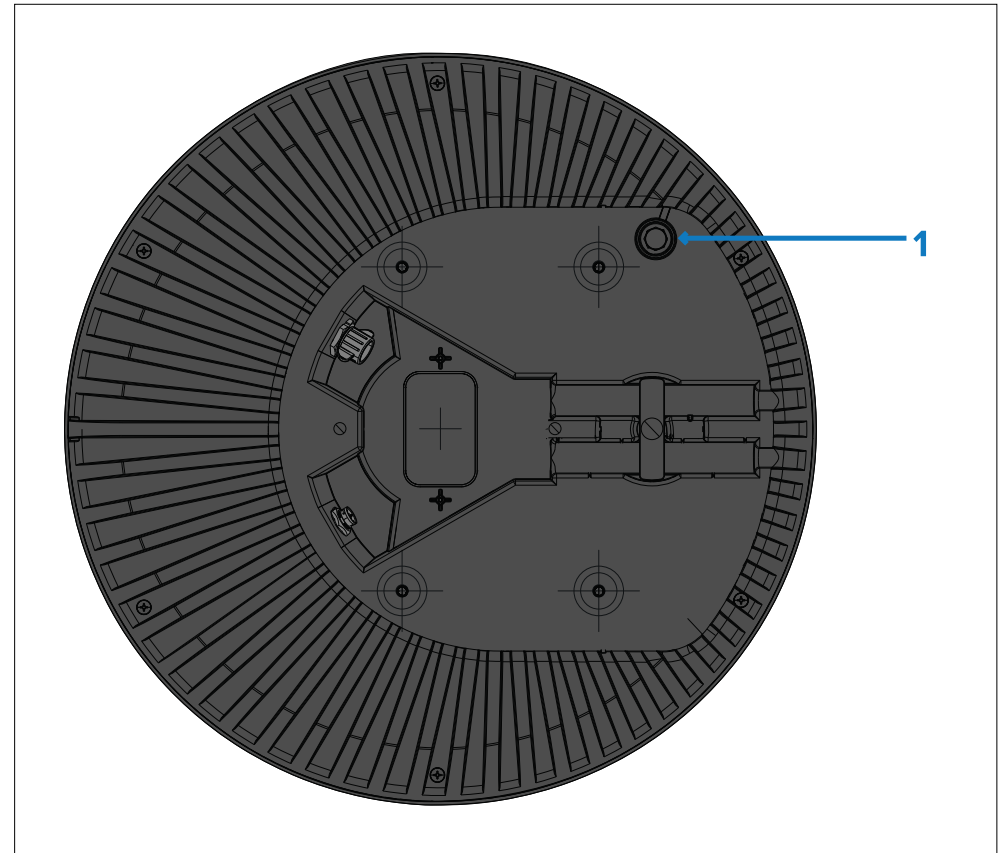

1. Location of "breather" holes.

Ensure that the breather is not blocked in any way. Examples of obstacles to airflow include sealant and paint.

If necessary, use additional washers to allow a small gap between the underside of the unit and the mounting surface, for airflow.

7.3 Mounting the scanner

Use a mounting location that:

- Is robust enough to support the Quantum™ scanner, under seagoing conditions.
- Meets the requirements described under *Scanner Position*.

Then:

1. Tape the template to the mounting platform, ensuring that the arrow on the template is pointed towards the front of the vessel.

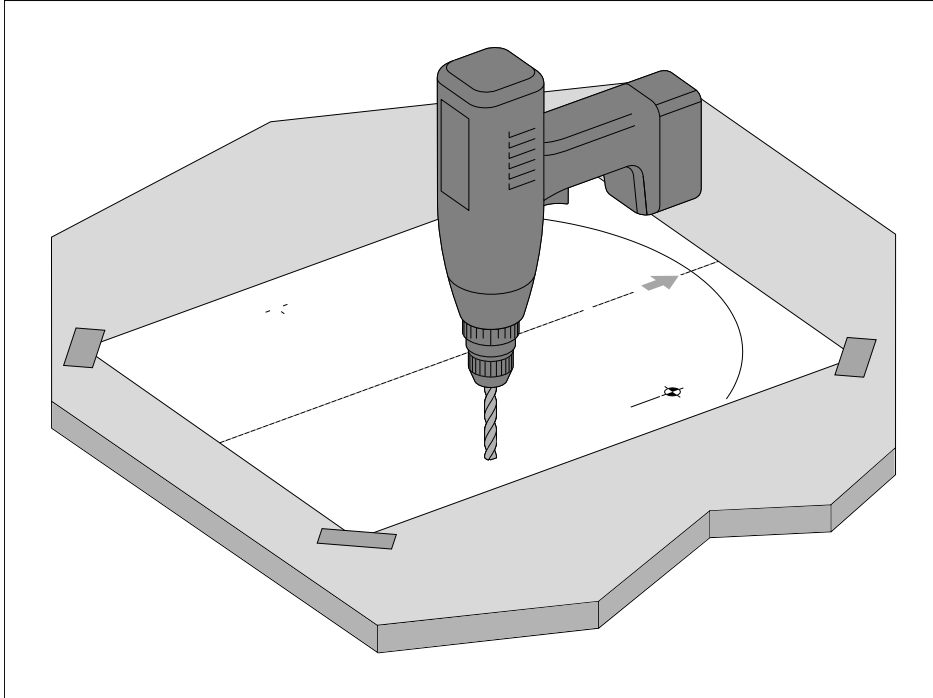

2. Drill 3 mm pilot holes in the 4 positions shown on the template.
3. Drill out the pilot holes to 10 mm diameter.
4. Place the Quantum™ scanner in position. If you are fitting it on a planing vessel, shim the rear of the scanner, so that the beam points slightly down

in the forward direction when the boat is at rest, to compensate for the bow rising at cruising speed

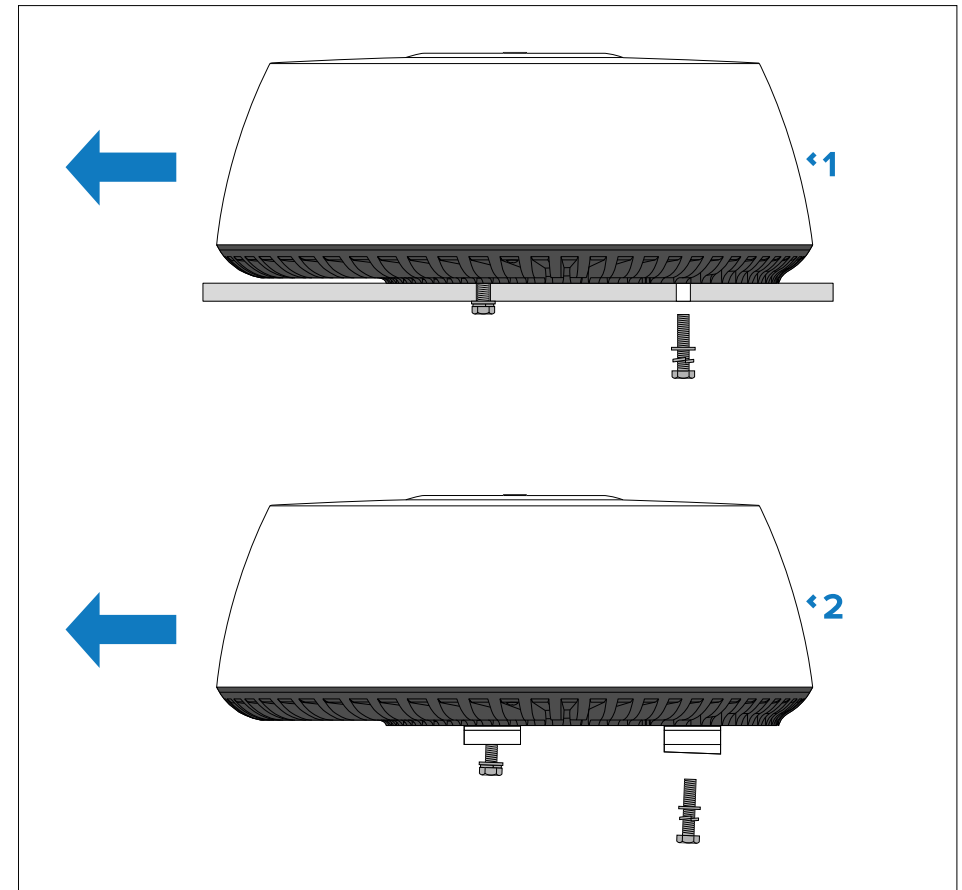

Item	Description
1	Mounting platform, non-planing boat (level install)
2	Mounting platform, planing boat (typical planing angle shown)

5. Before securing the scanner to the mounting platform, connect the power cable (and optionally a data cable), ensuring that all cables are routed appropriately. For further information about making connections and cable routing, refer to the follow section: [p.45 – Connections overview](#)
6. Ensuring that the bolts have a **minimum** insertion in the scanner base of 16 mm (0.63 in.), and a **maximum** of 22 mm (0.87 in.) (allowing for

washers), secure the scanner with the 4 bolts, flat washers and spring washers provided, as illustrated. If necessary, use appropriate shims or extra washers to limit the length of bolt entering the scanner base.

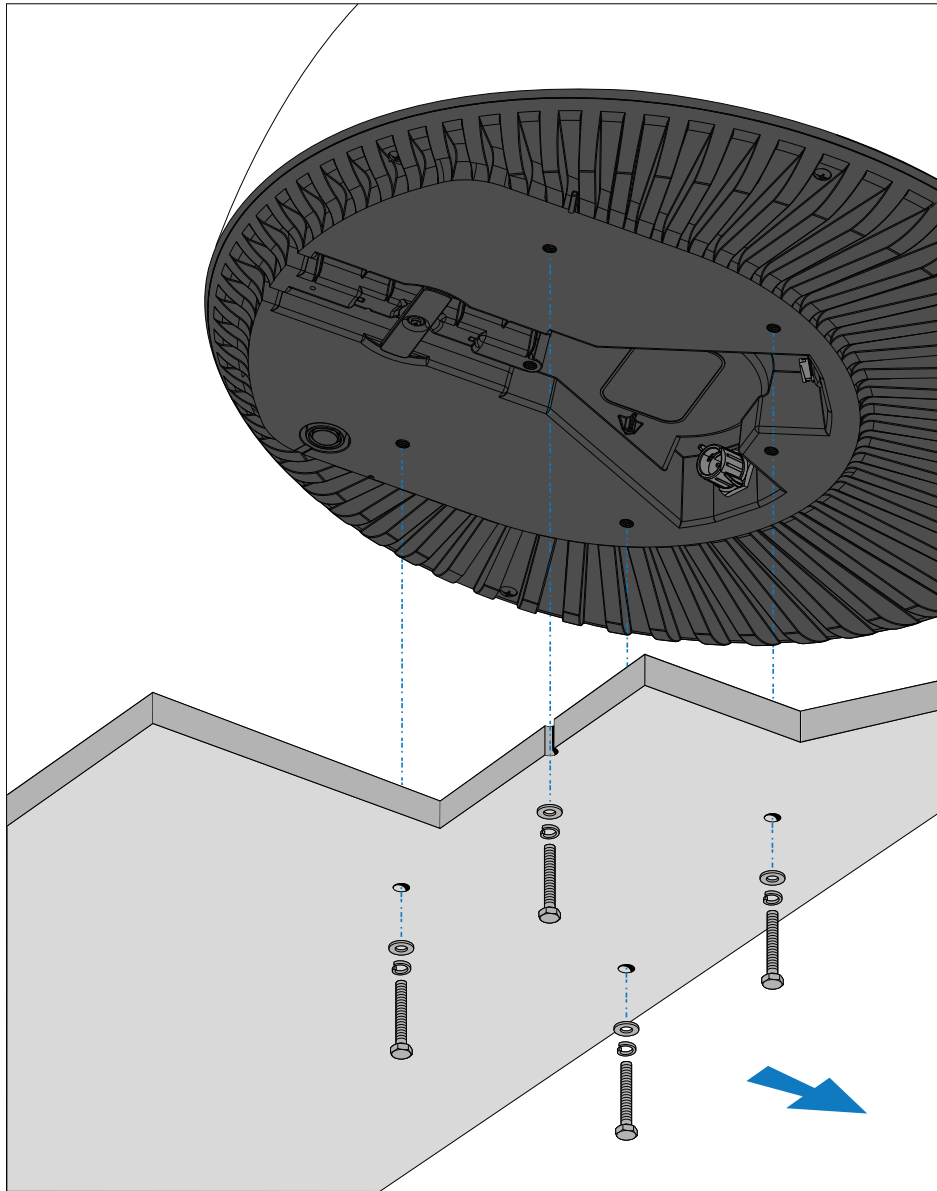

7. Tighten the bolts to a torque of 15 N·m (11 lbf-ft).

8. Attach a safety lanyard (not supplied) to your vessel, and secure the free end to the scanner using the attachment point shown in the following illustration:

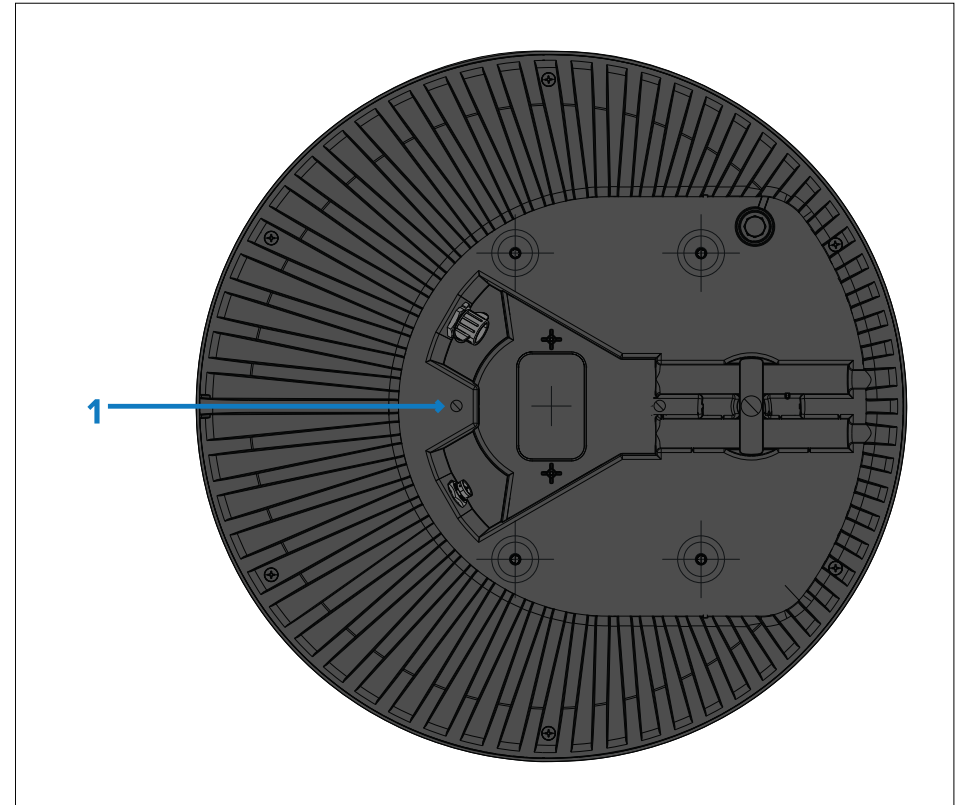

Item	Description
1	Safety lanyard attachment point.

Note:
If you are installing the Radar scanner on a sailing vessel, additional protection for the Radar scanner may be required. Refer to [p.41 – Radar scanner protection – sailing vessels](#)

Multiple Quantum Radar scanners

Only 1 (one) Quantum™ Radar scanner can be used at any one time, per networked system.

If you have more than one Quantum™ Radar scanner installed on your vessel and want to use them at the same time, the multifunction displays to which the scanners are connected must NOT be networked together. This applies to Quantum™ scanners connected either wired or wirelessly.

For more information, refer to:

[p.65 — Multiple Quantum Radars — more information](#)

Multiple Radar scanners — location requirements

Important location considerations when installing multiple radar scanners on the same vessel.

- Scanners should be mounted above each other, vertically separated by at least 0.5 m (1.6 ft). This applies to all installation locations on the vessel.
- Multiple scanners should be mounted in a way that minimizes interference between the vertical beamwidths of the 2 scanners.
- In all cases, you should aim to achieve as much physical separation as possible, to minimize any potential interference.

7.4 Radar scanner protection — sailing vessels

Additional considerations apply when installing the Radar scanner on a sailing vessel.

- When mounting the Radar scanner unit onto the mast, check that the unit is not fouled by the sails, especially when tacking.
- Depending on the type of sailing vessel and the design of the sailplan, a Radar scanner guard should be attached to the mast if the sails or rigging contact either the Radar scanner unit or the mounting bracket. Without a proper Radar guard, serious damage can result to the Radar mounting bracket and the Radar itself. In extreme cases, such damage could result in the Radar scanner unit being pulled off the mast. Therefore, it is recommended that a Radar scanner guard should be mounted additionally and separately to the Radar scanner mounting bracket.
- To prevent the risk of the Radar scanner unit falling after it has been damaged, the security lanyard supplied with the mast bracket **MUST** be secured properly to the mast and to the Radar scanner unit, according to the instructions provided with the bracket. If a safety lanyard is not supplied with the mounting bracket, contact your local dealer for appropriate parts. Do **NOT** attach other equipment to either the Radar scanner unit or the bracket.
- Raymarine® strongly recommends that you check the condition and security of the bracket mounting feet, the security lanyard(s), the Radar scanner guard, and the Radar scanner unit itself, on a yearly basis (or more frequently depending on environmental applications). Any fittings should be replaced as appropriate.

The following illustration shows an example of an installation featuring a Radar scanner fitted to a typical mounting bracket, a Radar guard attached to the mast (separately to the Radar mounting bracket), and safety lanyards:

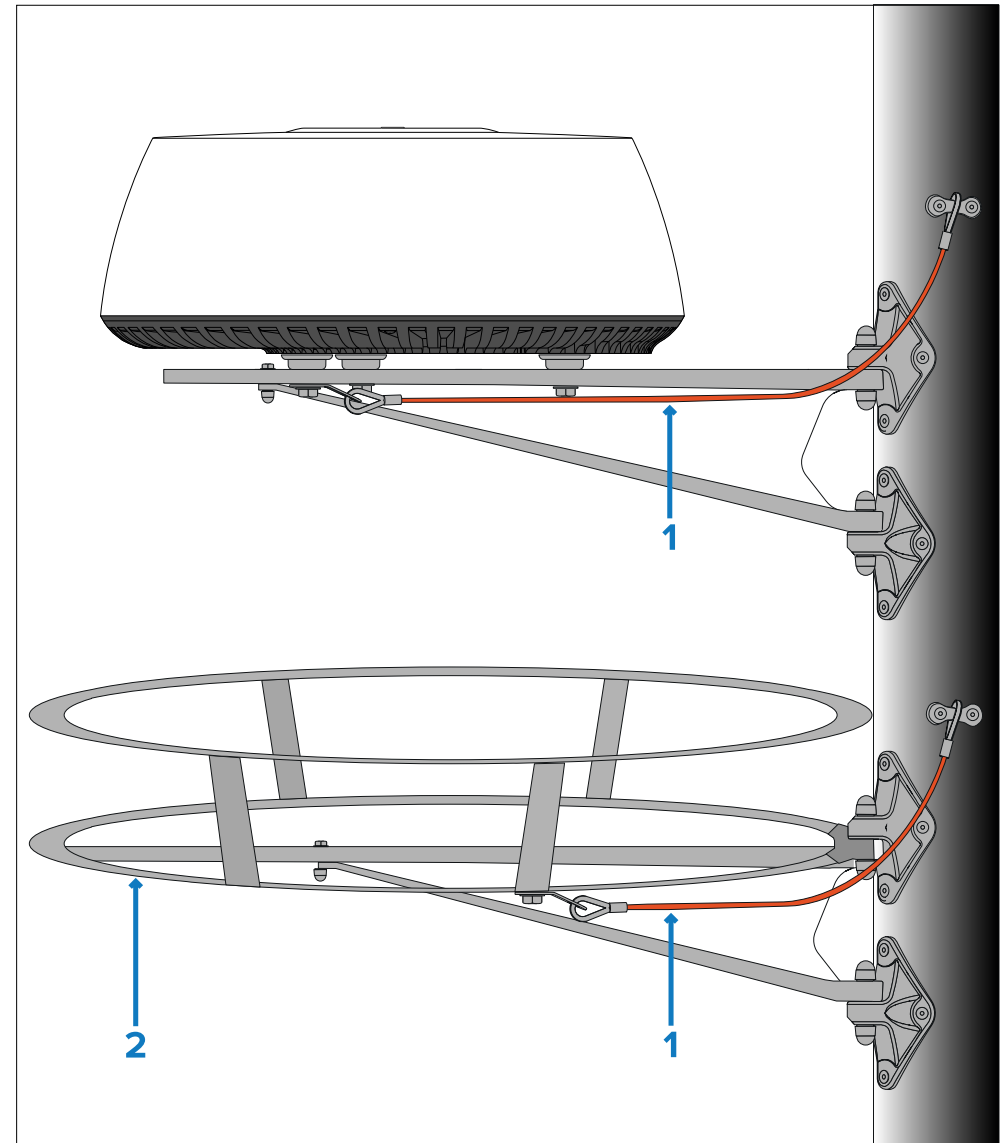

1. Example of a typical safety lanyard.
2. Example of a typical Radar scanner guard, attached to the mast independently of the Radar mounting bracket.

Note:

The Radar guard shown in the illustration above is provided as an example only. The exact design and positioning of the Radar guard is wholly dependent on the nature of your vessel, sailplan, and installation environment. For example, for some vessels it is appropriate to locate the guard above the Radar scanner; for other vessels, it may be more appropriate to fit it below the scanner. Raymarine® does not supply Radar guards but recommends that you select a guard that is attached directly to the mast and is completely separate to the Radar mounting bracket. It may be necessary to have a Radar guard custom designed to suit your specific vessel and installation environment. Please contact your local dealer for further advice.

CHAPTER 8: CABLES AND CONNECTIONS — GENERAL INFORMATION

CHAPTER CONTENTS

- 8.1 Cable types and length — page 44
- 8.2 Cable routing — page 44
- 8.3 Strain relief — page 44
- 8.4 Circuit isolation — page 44
- 8.5 Cable shielding — page 44
- 8.6 Suppression ferrites — page 44
- 8.7 Connections overview — page 45

8.1 Cable types and length

It is important to use cables of the appropriate type and length.

- Unless otherwise stated only use cables supplied by Raymarine.
- Where it is necessary to use non-Raymarine cables, ensure that they are of correct quality and gauge for their intended purpose. (e.g.: longer power cable runs may require larger wire gauges to minimize voltage drop along the run).

8.2 Cable routing

Cables must be routed correctly, to maximize performance and prolong cable life.

- Do NOT bend cables excessively. Wherever possible, ensure a minimum bend diameter (\emptyset) of 200 mm (7.87 in) / minimum bend radius (R) of 100 mm (3.94 in).

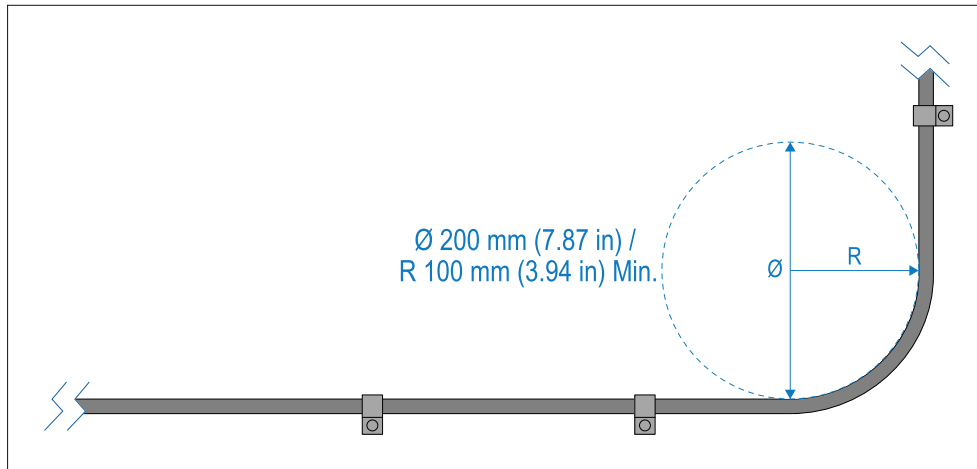

- Protect all cables from physical damage and exposure to heat. Use trunking or conduit where possible. Do NOT run cables through bilges or doorways, or close to moving or hot objects.
- Secure cables in place using cable clips or cable ties. Coil any excess cable and tie it out of the way.
- Where a cable passes through an exposed bulkhead or deckhead, use a suitable watertight feed-through.

- Do NOT run cables near to engines or fluorescent lights.
- Always route data cables as far away as possible from:
 - Other equipment and cables.
 - High current carrying AC and DC power lines.
 - Antennas.

8.3 Strain relief

Use adequate strain relief for cabling to ensure that connectors are protected from strain and will not pull out under extreme sea conditions.

8.4 Circuit isolation

Appropriate circuit isolation is required for installations using both AC and DC current:

- Always use isolating transformers or a separate power-inverter to run PCs, processors, displays and other sensitive electronic instruments or devices.
- If using Weather FAX audio cables, always use an isolating transformer.
- If using a third-party audio amplifier, always use an isolated power supply.
- If using an RS232/NMEA converter, always ensure optical isolation on the signal lines.
- Always ensure that PCs or other sensitive electronic devices have a dedicated power circuit.

8.5 Cable shielding

Ensure that cable shielding is not damaged during installation and that all cables are properly shielded.

8.6 Suppression ferrites

- Raymarine® cables may be pre-fitted or supplied with suppression ferrites. These are important for correct EMC performance. If ferrites are supplied

separately to the cables (i.e. not pre-fitted), you must fit the supplied ferrites, using the supplied instructions.

- If a ferrite has to be removed for any purpose (e.g. installation or maintenance), it must be replaced in the original position before the product is used.
- Use only ferrites of the correct type, supplied by Raymarine® or its authorized dealers.
- Where an installation requires multiple ferrites to be added to a cable, additional cable clips should be used to prevent stress on the connectors due to the extra weight of the cable.

8.7 Connections overview

Use the following information to help you identify the connections on your product.

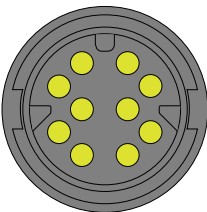
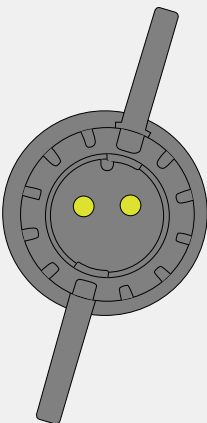
Connector	Connection
	Connects to a RayNet network or device. Not required if connecting using Wi-Fi. For further information on the suitable cables, refer to the following section: p.79 – Spares and accessories
	Connects to a 12 V / 24 V power supply. A suitable power cable is supplied with your product.

The power and data connections are located on the underside of the scanner unit, as shown in the following illustration.

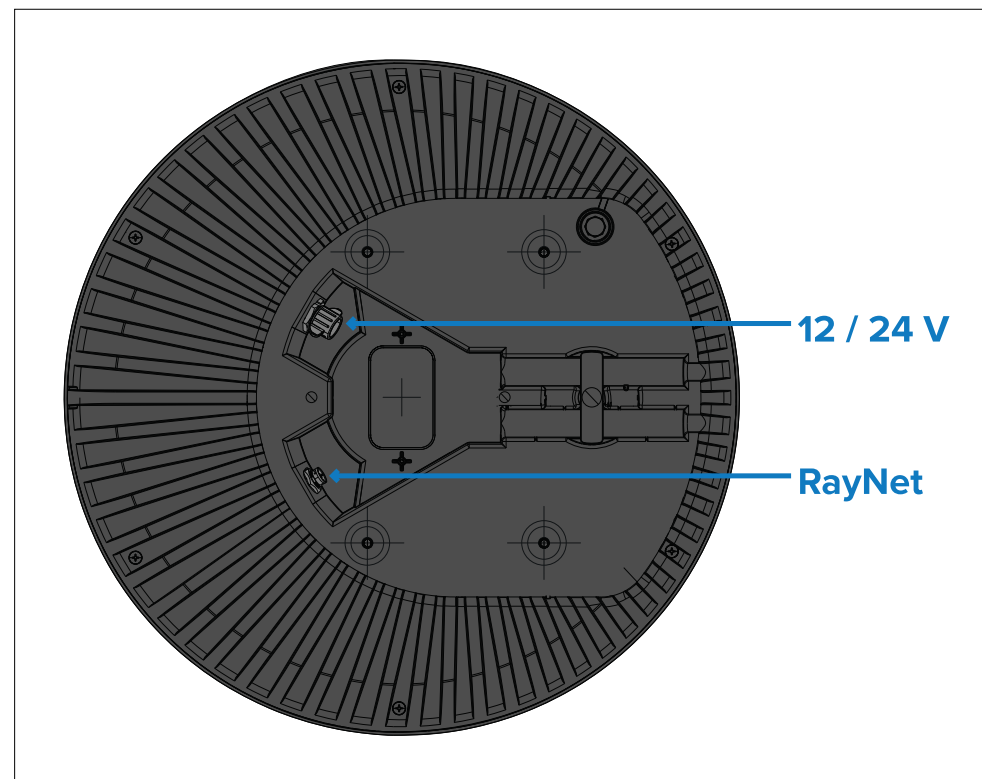

Typical cable routing scenarios

There are 4 typical cable routing scenarios.

Note:

The routing options described and illustrated in this section assume that a physical data connection is used between your Radar scanner and multifunction display (MFD). However, if the scanner is connected to your MFD via Wi-Fi, a physical RayNet connection is not required.

1. Cable routing for a scanner mounted on a platform, using separate cables for the power and data connection.

2. Cable routing for a scanner mounted on a platform, using the combined power and data cable from an existing Raymarine® Digital Radar scanner installation. For this, the **A80308** Y-adapter accessory is required (not supplied with the scanner).
3. Cable routing for a scanner mounted on a pole, using separate cables for the power and data connection.
4. Cable routing for a scanner mounted on a pole, using the combined power and data cable from an existing Raymarine® Digital Radar scanner installation. For this, the **A80308** Y-adapter accessory is required (not supplied with the scanner).

Cable routing — platform mount

There are 2 typical cable routing scenarios for platform mount installations.

1. Using separate power and data cables.
2. Using an existing combined power / data cable from an older Raymarine® Digital Radar scanner. In this scenario, the **A80308** Y-adapter accessory is required (not supplied with the scanner).

Note:

The routing options described and illustrated in this section assume that a physical data connection is used between your Radar scanner and multifunction display (MFD) / chartplotter. However, if the Radar scanner is connected to your MFD via Wi-Fi, a physical RayNet connection is not required.

Scenario 1: Using separate power and data cables

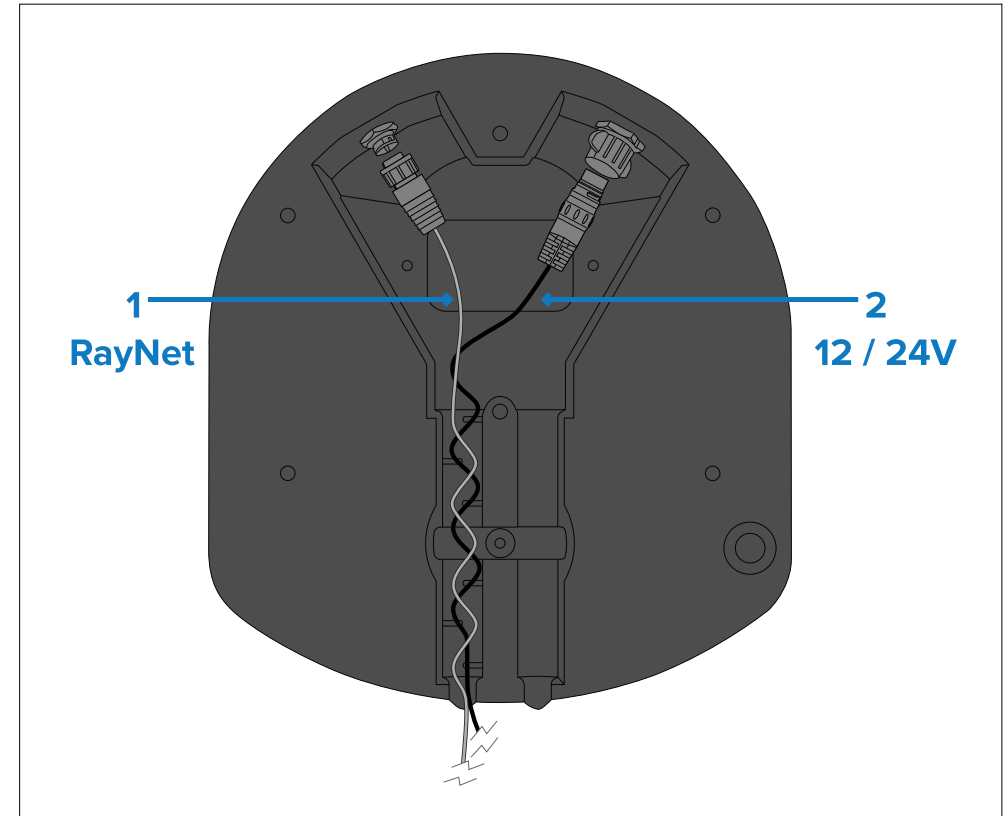

1. RayNet data connection. (This connection is not required if connecting to the MFD via Wi-Fi.)
2. 12 V / 24 V power connection, via the supplied power cable.

Note:

- Not all Quantum™ radar variants are supplied with a RayNet cable. For more information, refer to: [p.14 — Document information](#)
- For information on suitable accessory RayNet cables, refer to: [p.79 — Spares and accessories](#)

Scenario 2: Using an existing combined power / data cable from an older Raymarine® Digital Radar

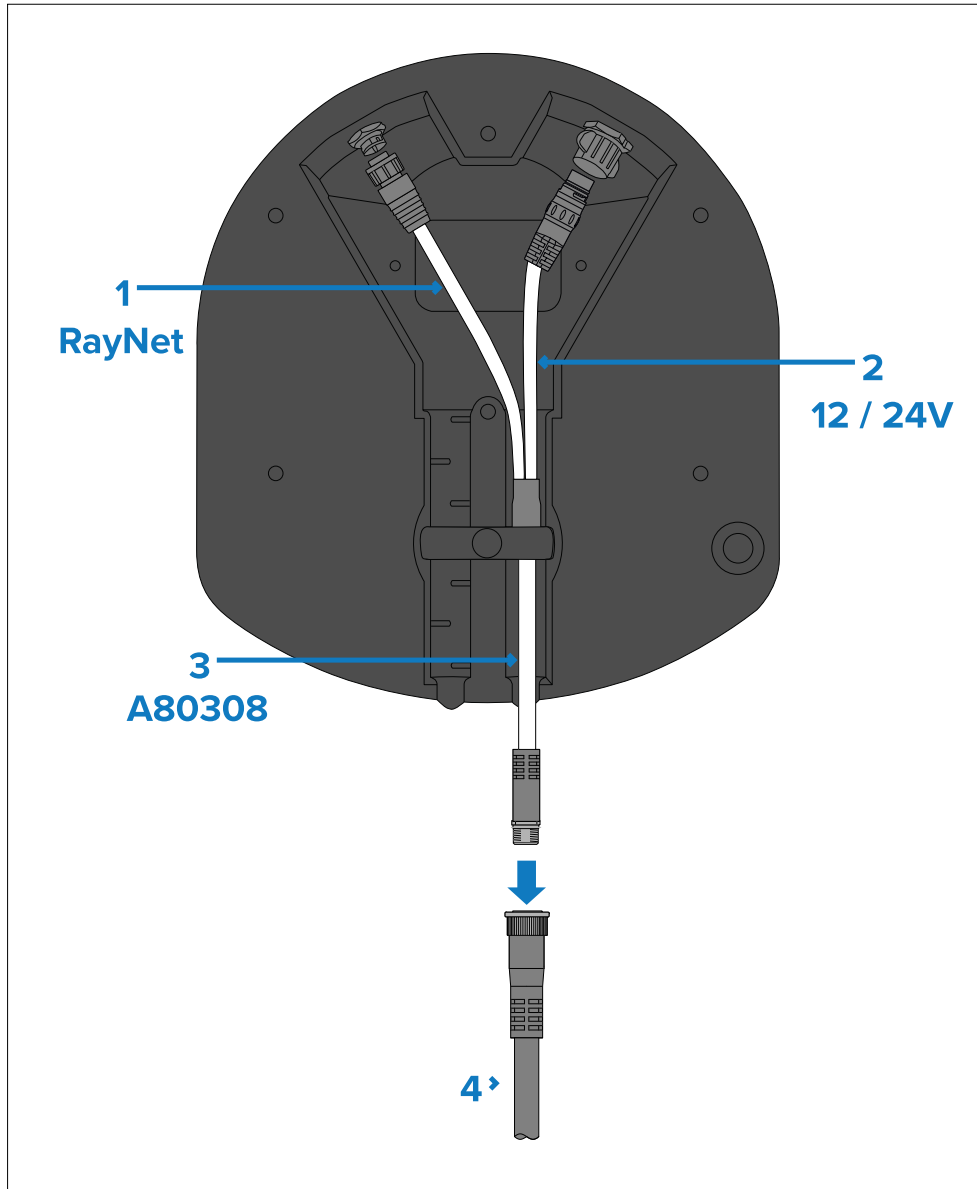

1. RayNet data connection. (This connection is not required if connecting to the MFD via Wi-Fi.). This cable is part of the **A80308** Y-adaptor accessory cable.
2. 12 V / 24 V power connection. This cable is part of the **A80308** Y-adaptor accessory cable.
3. **A80308** Y-adaptor accessory cable (not supplied with the scanner).
4. Existing combined Digital Radar power / data cable.

Cable routing — pole mount

There are 2 typical cable routing scenarios for pole mount installations.

1. Using separate power and data cables.
2. Using an existing combined power / data cable from an older Raymarine® Digital Radar scanner. In this scenario, the **A80308** Y-adaptor accessory is required (not supplied with the scanner).

Note:

The routing options described and illustrated in this section assume that a physical data connection is used between your Radar scanner and multifunction display (MFD) / chartplotter. However, if the Radar scanner is connected to your MFD via Wi-Fi, a physical RayNet connection is not required.

Scenario 1: Using separate power and data cables

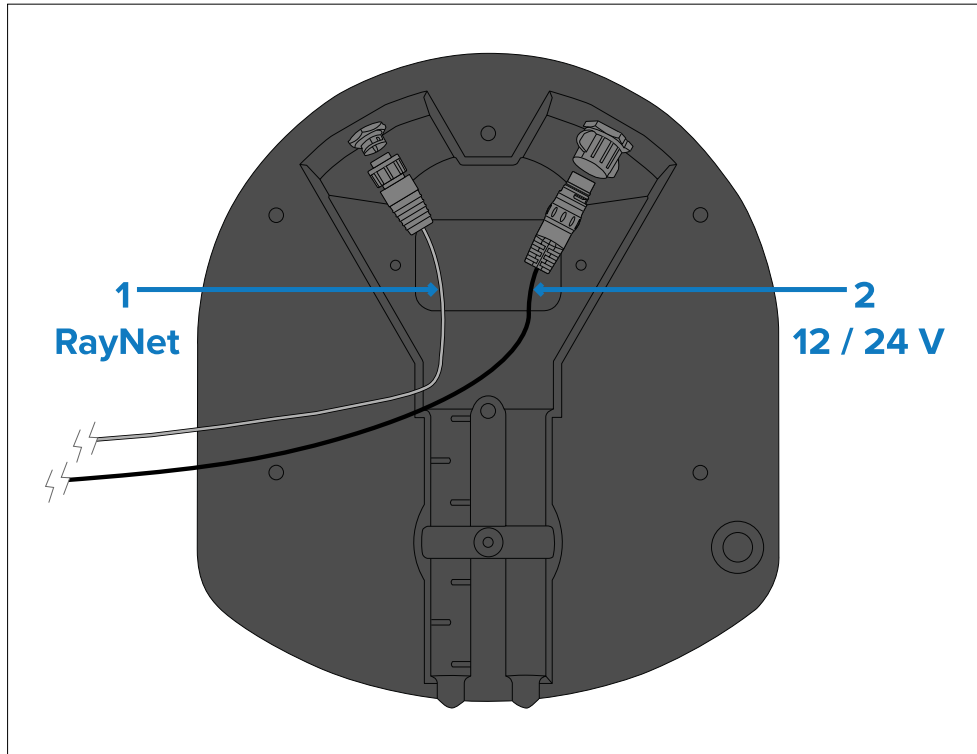

1. RayNet data connection. (This connection is not required if connecting to the MFD via Wi-Fi.)
2. 12 V / 24 V power connection, via the supplied power cable.

Note:

- Not all Quantum™ radar variants are supplied with a RayNet cable. For more information, refer to: [p.14 – Document information](#)
- For information on suitable accessory RayNet cables, refer to: [p.79 – Spares and accessories](#)

Scenario 2: Using an existing combined power / data cable from an older Raymarine Digital Radar

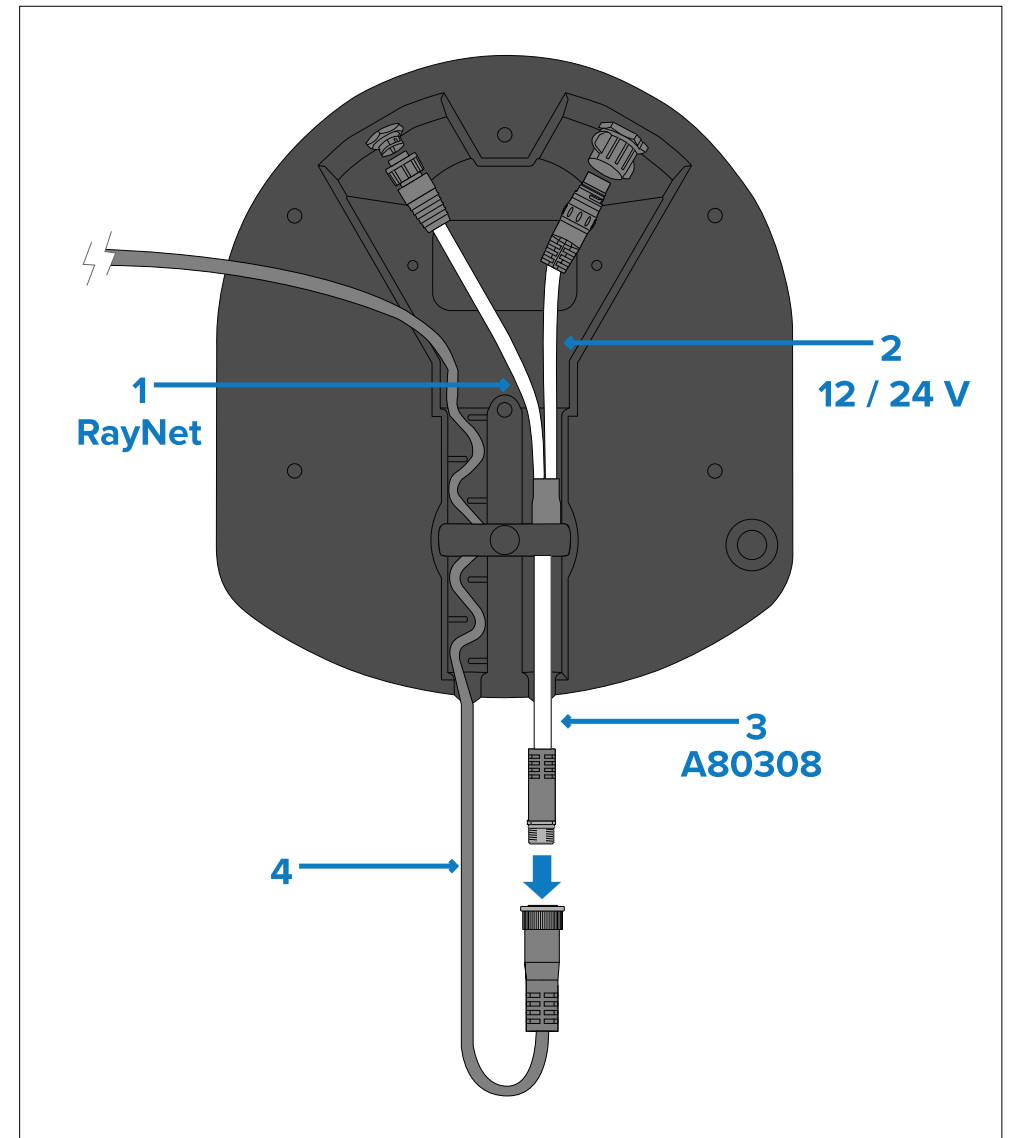

Note:

The Y-adapter cable is actually white. For clarity, it is shown in the above drawing in different colors.

1. RayNet data connection. (This connection is not required if connecting to the MFD via Wi-Fi.). This cable is part of the **A80308** Y-adapter accessory cable.
2. 12 V / 24 V power connection. This cable is part of the **A80308** Y-adapter accessory cable.
3. **A80308** Y-adapter accessory cable (not supplied with the scanner).
4. Existing combined Digital Radar power / data cable.

Making connections

Follow the steps below to connect the cable(s) to your product. If you intend to use the scanner's Wi-Fi functionality to connect to your multifunction display, you need only connect a power cable to the scanner.

Note:

If your vessel is already fitted with a combined power / data Digital Radar cable, you can use a Y-adapter (part number A80308) to connect the existing cable-end to the scanner's connectors.

1. Ensure that the vessel's power supply is switched off.
2. Ensure that the multifunction display being connected to the scanner has been installed in accordance with the installation instructions supplied with that device.
3. Ensure the power connector locking collar on the scanner is in the unlocked position.
4. Route the power cable and optional data cable within the scanner base, as shown in the cable routing illustrations in this section. Cable routing depends on whether you mount the scanner on a platform or on a pole, and on whether you are using a Y-adapter to connect to an existing combined power / data Digital Radar cable.
5. Ensure that the power cable connector is orientated so that the notch lines up with the guide in the connector.
6. Push the power cable connector all the way into the scanner's power connector.

7. Rotate the locking collar clockwise until it is in the locked position (2 clicks).
8. Push the optional data cable fully onto the corresponding connector on the scanner.
9. If you are using a Y-adapter, make the final connection between the adapter and the existing combined power / data Digital Radar cable.

Note:

When switching from a Wi-Fi connection to a wired connection for the Quantum Radar, you may encounter a connection issue if the Wi-Fi connection is established before the wired adaptor completes its initialization procedure. To resolve this issue, upgrade your Quantum unit to the latest software version, and then power cycle the unit.

CHAPTER 9: NETWORK CONNECTIONS

CHAPTER CONTENTS

- [9.1 Network cable connector types — page 51](#)
- [9.2 Network connections — page 51](#)
- [9.3 Network connection — wired \(single display\) — page 51](#)
- [9.4 Network connection — wireless \(Wi-Fi\) — page 52](#)
- [9.5 Network connection — wired \(multiple displays\) — page 52](#)

9.1 Network cable connector types

There are 3 types of network cable connectors — RayNet, RJ45 (SeaTalkhs®), and RJ45.

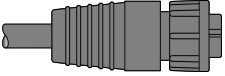
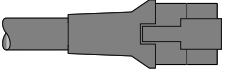
Connector	Description
	RayNet
	RJ45 (SeaTalkhs®) for connection to (legacy) Raymarine equipment featuring a SeaTalkhs® connector.
	RJ45

9.2 Network connections

The scanner must be connected to a compatible Raymarine multifunction display (MFD), either via Wi-Fi, or via a physical RayNet cable connection. Once connected, the multifunction display can show Radar echo data.

The following section provides examples of 3 different connection scenarios that may be applicable when connecting the Radar to your equipment:

1. [p.51 — Wired \(RayNet\) multifunction display network connection](#)
2. [p.52 — Wi-Fi multifunction display network connection](#)
3. [p.52 — Multiple multifunction display network configuration](#)

9.3 Network connection — wired (single display)

Radar scanner connected to a multifunction display using a RayNet cable.

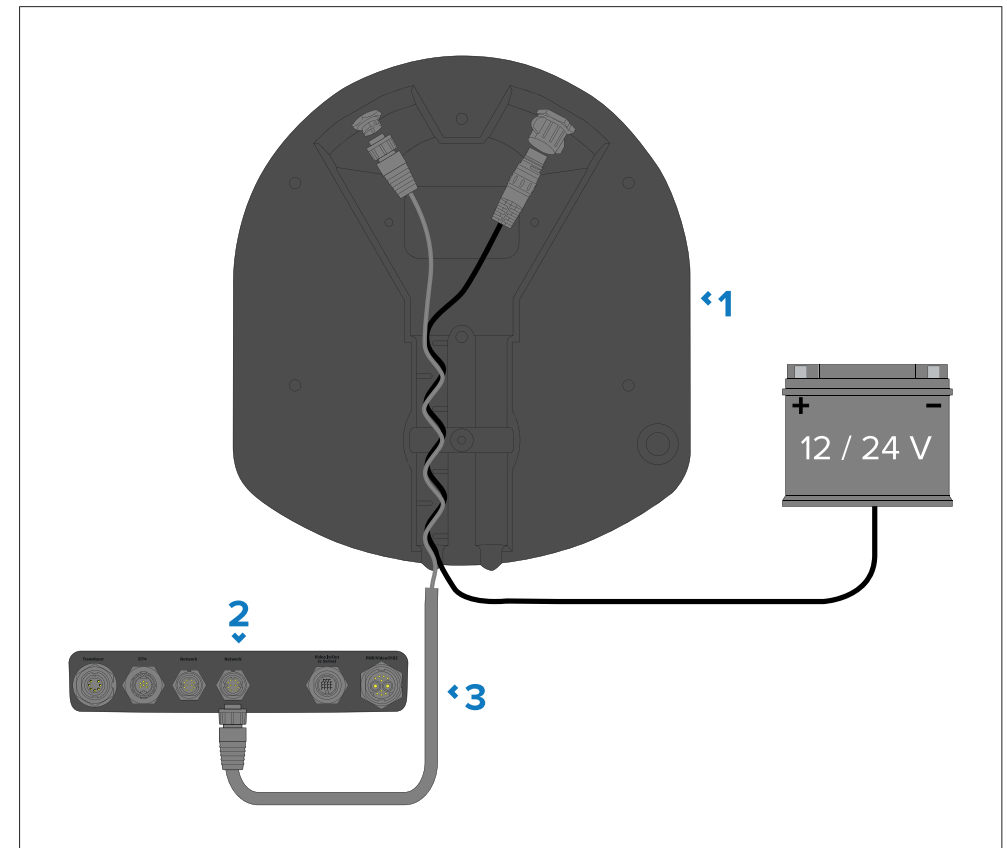

Item	Description
1	Quantum™ Radome (for clarity, only the connections area of the underside of the unit is shown here).
2	Connector panel of compatible Raymarine® multifunction display (for clarity, only the connections area of the unit is shown here).
3	RayNet data cable.

9.4 Network connection — wireless (Wi-Fi)

Radar scanner connected to a multifunction display via Wi-Fi.

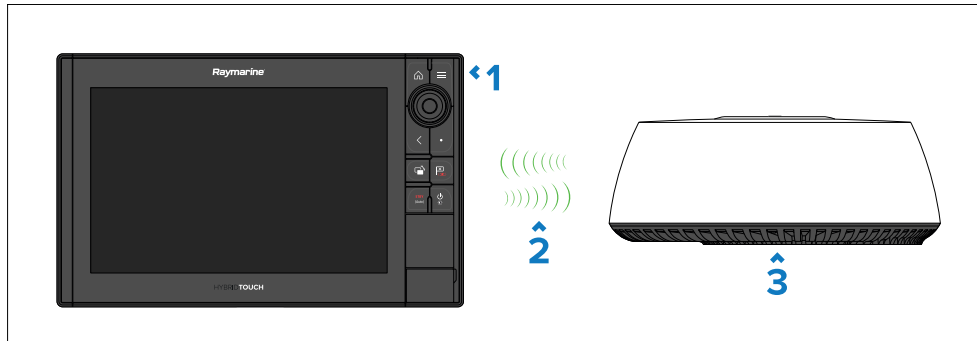

Note:

Power connections are not shown in the above illustration. The MFD and Quantum each require their own dedicated power supplies.

Item	Description
1	Compatible Raymarine® multifunction display with Wi-Fi capability.
2	Quantum™ Radome with Wi-Fi capability.
3	Wi-Fi datalink.

Note:

Refer to your MFD documentation and the following section for further information about setting up the Wi-Fi connection between your MFD and the Quantum™ Radar scanner: [p.58 — System checks and troubleshooting](#)

9.5 Network connection — wired (multiple displays)

A Raymarine® network switch can be used to connect the Radar scanner to more than one multifunction display at the same time.

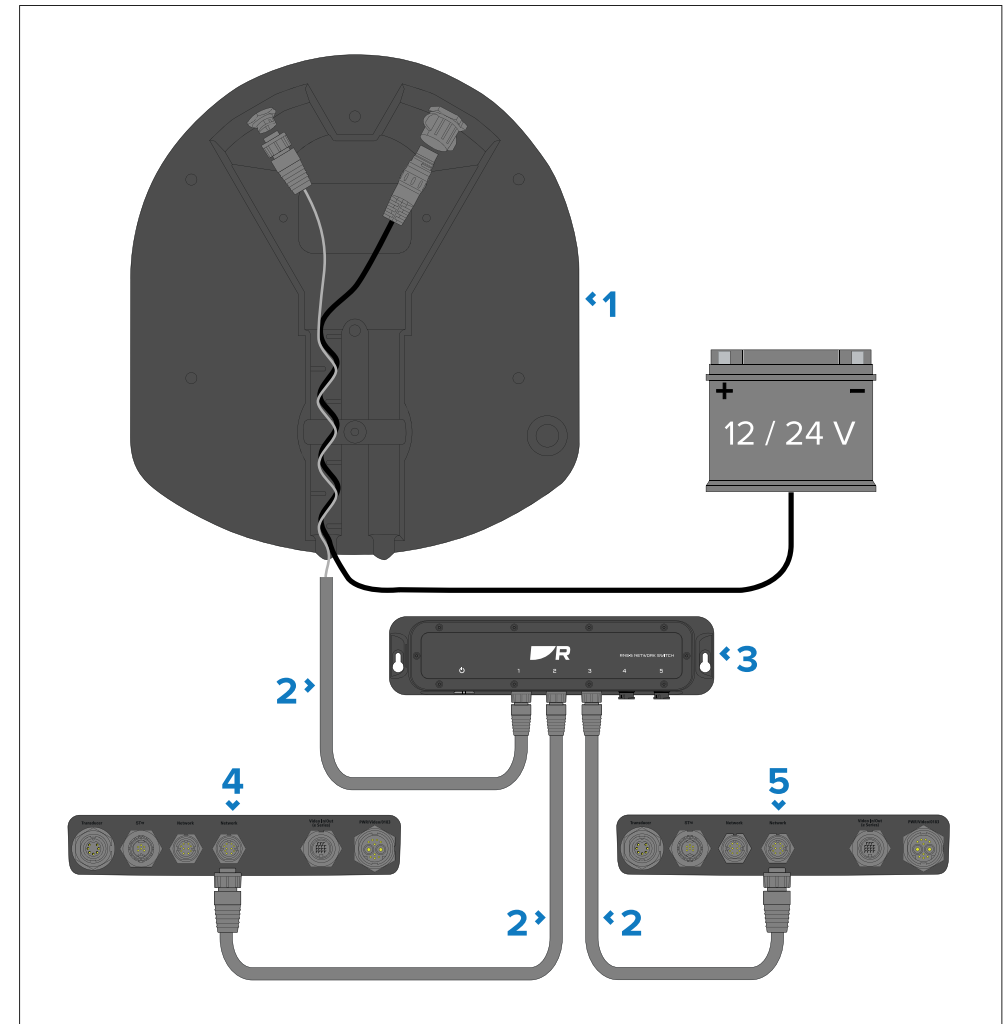

Item	Description
1	Quantum™ radome (for clarity, only the connections area of the underside of the unit is shown here).
2	RayNet cable.
3	RayNet network switch.
4	Connector panel of compatible Raymarine® multifunction display (for clarity, only the connections area of the unit is shown here).
5	Connector panel of additional compatible Raymarine® multifunction display (for clarity, only the connections area of the unit is shown here).

CHAPTER 10: POWER CONNECTIONS

CHAPTER CONTENTS

- 10.1 Power connection — page 55
- 10.2 In-line fuse and thermal breaker ratings — page 55
- 10.3 Grounding not required — page 55
- 10.4 Power distribution — page 55
- 10.5 Power cable extension (12 / 24 V systems) — page 57
- 10.6 Grounding not required — page 57

10.1 Power connection

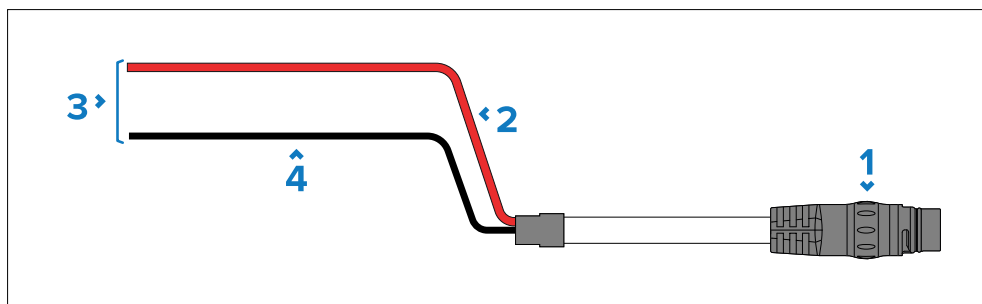

Note:

A Y-adapter cable (part number A80308) is available for existing installations that already use a combined power/data cable from a Digital or HD Color Radome. The Y-adapter splits the existing combined cable into the separate data and power connectors used by the scanner.

Item	Description
1	Power cable, connects to the product's power connector.
2	Red wire (positive), connects to the power supply's positive terminal.
3	Connection to 12 V / 24 V power supply.
4	Black wire (negative), connects to the power supply's negative terminal.

10.2 In-line fuse and thermal breaker ratings

The following in-line fuse and thermal breaker ratings apply to your product:

In-line fuse rating	Thermal breaker rating
5 A	3 A

Note:

- The suitable fuse rating for the thermal breaker is dependent on the number of devices you are connecting. If in doubt consult an authorized Raymarine® dealer.
- Your product's power cable may have an in-line fuse fitted, if not then you must add an in-line fuse / breaker to the positive wire of your product's power connection.

10.3 Grounding not required

This product is fully insulated and does NOT require separate grounding.

10.4 Power distribution

Recommendations and best practice.

- The product is supplied with a power cable, either as a separate item or a captive cable permanently attached to the product. Only use the power cable supplied with the product. Do NOT use a power cable designed for, or supplied with, a different product.
- Refer to the *Power connection* section for more information on how to identify the wires in your product's power cable, and where to connect them.
- See below for more information on implementation for some common power distribution scenarios:

Important:

- When planning and wiring, take into consideration other products in your system, some of which (e.g. sonar modules) may place large power demand peaks on the vessel's electrical system, which may impact the voltage available to other products during the peaks.
- The information provided below is for guidance only, to help protect your product. It covers common vessel power arrangements, but does NOT cover every scenario. If you are unsure how to provide the correct level of protection, please consult an authorized dealer or a suitably qualified professional marine electrician.

Implementation — connection to distribution panel (Recommended)

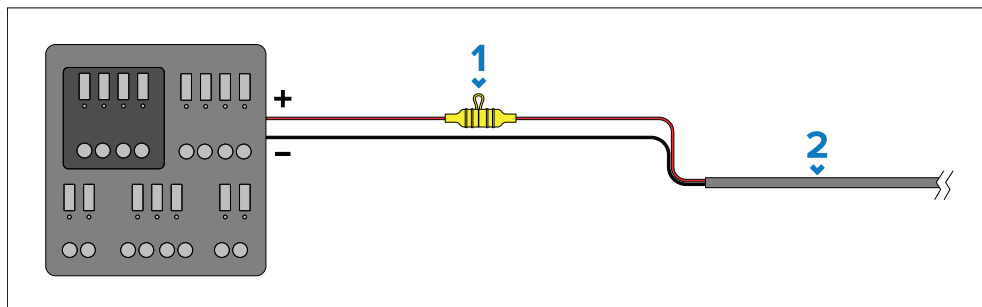

Item	Description
1	Waterproof fuse holder containing a suitably-rated inline fuse must be fitted. For suitable fuse rating, refer to: <i>Inline fuse and thermal breaker ratings</i> .
2	Product power cable.

- It is recommended that the supplied power cable is connected to a suitable breaker or switch on the vessel's distribution panel or factory-fitted power distribution point.
- The distribution point should be fed from the vessel's primary power source by 8 AWG (8.36 mm²) cable.
- Ideally, all equipment should be wired to individual suitably-rated thermal breakers or fuses, with appropriate circuit protection. Where this is not possible and more than one item of equipment shares a breaker, use individual inline fuses for each power circuit to provide the necessary protection.

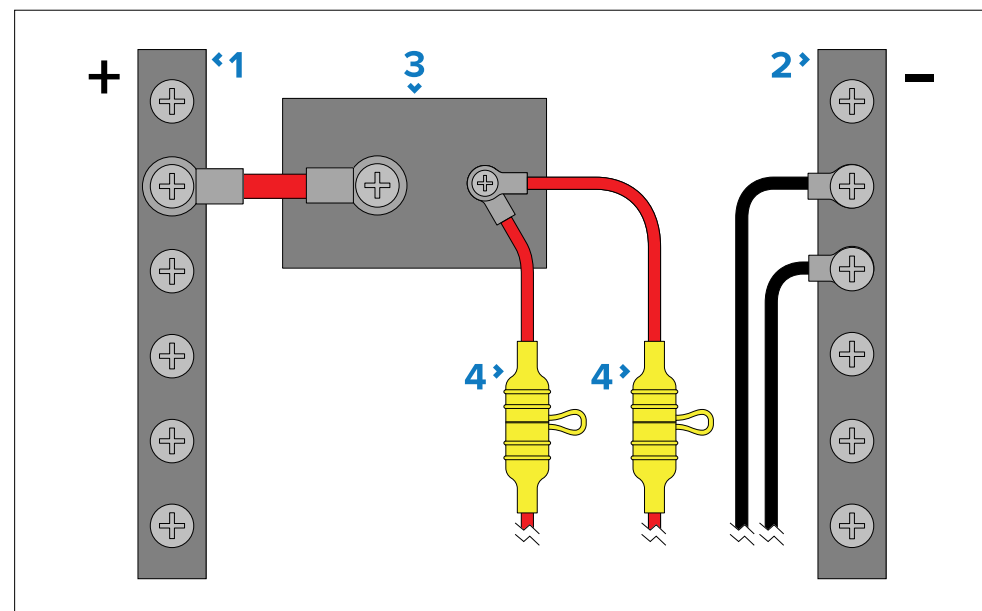

Item	Description
1	Positive (+) bar
2	Negative (-) bar
3	Circuit breaker
4	Waterproof fuse holder containing a suitably-rated inline fuse must be fitted. For suitable fuse rating, refer to: <i>Inline fuse and thermal breaker ratings</i> .

Important:

Observe the recommended fuse / breaker ratings provided in the product's documentation, however be aware that the suitable fuse / breaker rating is dependent on the number of devices being connected.

Implementation — direct connection to battery

- Where connection to a power distribution panel is not possible, the power cable supplied with your product may be connected directly to the vessel's battery, via a suitably rated fuse or breaker.

- The power cable supplied with your product does NOT include a separate drain wire. Therefore, only the power cable's red and black wires need to be connected.
- If the power cable is NOT supplied with a fitted inline fuse, you **MUST** fit a suitably rated fuse or breaker between the red wire and the battery's positive terminal.
- Refer to the inline fuse ratings provided in the product's documentation.
- If you need to extend the length of the power cable supplied with your product, ensure you observe the dedicated *Power cable extensions* advice provided in the product's documentation.

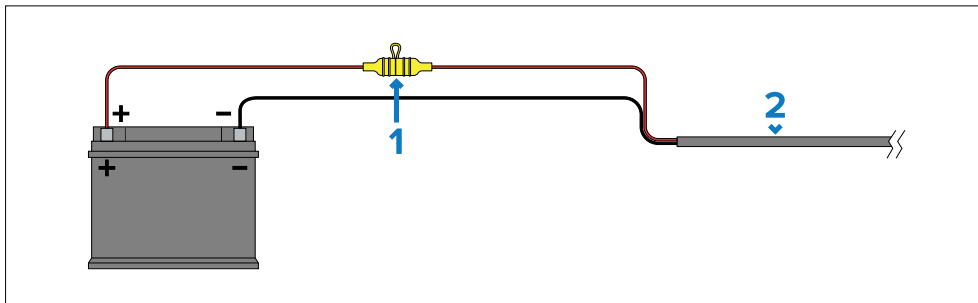

Item	Description
1	Waterproof fuse holder containing a suitably-rated inline fuse must be fitted. For suitable fuse rating, refer to: <i>Inline fuse and thermal breaker ratings</i> .
2	Product power cable.

More information

It is recommended that best practice is observed in all vessel electrical installations, as detailed in the following standards:

- BMEA Code of Practice for Electrical and Electronic Installations in Boats
- NMEA 0400 Installation Standard
- ABYC E-11 AC & DC Electrical Systems on Boats
- ABYC A-31 Battery chargers and Inverters
- ABYC TE-4 Lightning Protection

10.5 Power cable extension (12 / 24 V systems)

If you need to extend the length of the power cable supplied with your product, ensure you observe the following advice:

- The power cable for each unit in your system should be run as a separate, single length of 2-wire cable from the unit to the vessel's battery or distribution panel.
- Ensure that the extension cable is of a sufficient gauge for the supply voltage and the total load of the device and the length of the cable run. Refer to the following table for typical **minimum** power cable wire gauges:

Cable length in meters (feet)	Wire gauge in AWG (mm ²) for 12 V supply	Wire gauge in AWG (mm ²) for 24 V supply
<8 (<25)	16 (1.31 mm ²)	18 (0.82 mm ²)
16 (50)	14 (2.08 mm ²)	18 (0.82 mm ²)
24 (75)	14 (2.08 mm ²)	16 (1.31 mm ²)
>32 (>100)	14 (2.08 mm ²)	16 (1.31 mm ²)

Important:

Be aware that some products in your system (such as sonar modules) can create voltage peaks at certain times, which may impact the voltage available to other products during the peaks.

Important:

To ensure power cables (including any extension) are of a sufficient gauge, ensure that there is a continuous **minimum** voltage of **10.8 V dc** at the end of the cable where it enters the product's power connector, even with a fully flat battery at 11 V dc. (Do not assume that a flat battery is at 0 V dc. Due to the discharge profile and internal chemistry of batteries, the current drops much faster than the voltage. A "fully flat" battery still shows a positive voltage, even if it doesn't have enough current to power your device.)

10.6 Grounding not required

This product is fully insulated and does NOT require separate grounding.

CHAPTER 11: SYSTEM CHECKS AND TROUBLESHOOTING

CHAPTER CONTENTS

- 11.1 Post installation procedures — page 59
- 11.2 Troubleshooting — page 63

11.1 Post installation procedures

Before using the product, carry out the following:

- Mechanical checks.
- Switch on and initial setup.

Mechanical checks

Before switching on the product:

- Ensure that:
 - All securing bolts are fully tightened and the appropriate mechanical locking washers are in place.
 - All connections are securely made.
 - All connecting cables and wires are secured and protected as necessary.
- Ask your local Raymarine authorized installer to check the installation.

Connecting to a Radar scanner over RayNet

Once you've made all the relevant power and data connections as described in the *Cables and connections* section, you can use the Radar application on a compatible display to conduct further initial tests.

For detailed instructions on how to conduct the initial tests, refer to the *Radar application* chapter of the Operations handbook for your display.

Powering on a Quantum Radar

With the radar scanner in a powered off state, and connected to a compatible multifunction display (MFD):

1. On the MFD, launch the Radar application.
A message box is displayed indicating that a Radar scanner is off or “not connected”.
2. Select *[On]* from the onscreen message box.
The Radar will power up in Standby mode.
3. Once the Radar has powered up, select *[Tx]* to start the Radar transmitting.

Radar returns will now be displayed onscreen.

Pairing with a Quantum Radar using Wi-Fi

If your Radar scanner supports a Wi-Fi connection, you can connect to a LightHouse™ MFD which also supports Wi-Fi. During pairing, the Wi-Fi credentials of all MFDs with Wi-Fi switched on are sent to the Quantum Radar. At subsequent power cycles the Quantum Radar will automatically connect to the MFD with the strongest signal.

Note:

1. During initial set up you will have 60 minutes (for Quantum Doppler software versions 2.43 or later) or 10 minutes (for earlier Quantum Doppler software versions) in which to connect the Radar to your MFD. After this time, if no connection is made, the Radar will automatically go to Sleep. If this occurs, power cycle the Radar to bring it out of Sleep mode and establish a connection.
2. Networked MFDs that only have their Wi-Fi enabled after the initial pairing period, will send Wi-Fi credentials to the Radar when their Wi-Fi is switched on.

1. Apply power to your MFD(s).
2. Power on and then enable the Wi-Fi connection to the MFDs which have the strongest signal (typically these will be the MFDs closest to and / or with the clearest line of sight to the Radar), as identified during the [p.34 — pre-installation site survey](#)
3. Apply power to your Radar scanner.
4. Select *[Quantum Radar]* from the settings menu on the MFD:
 - i. On a LightHouse™ 4 / LightHouse™ 3 MFD: *[Homescreen > Settings > This display (tab) > Pair with Quantum]*.
5. If prompted, select *[OK]* to enable your MFD's Wi-Fi connection.
6. Enter the passcode (e.g. 901589f5) in the *[Passcode]* field.
for details on locating your SSID and Passcode, refer to the following section: [p.61 — Retain your Wi-Fi Passcode](#)

LightHouse™ 4 connection screen:

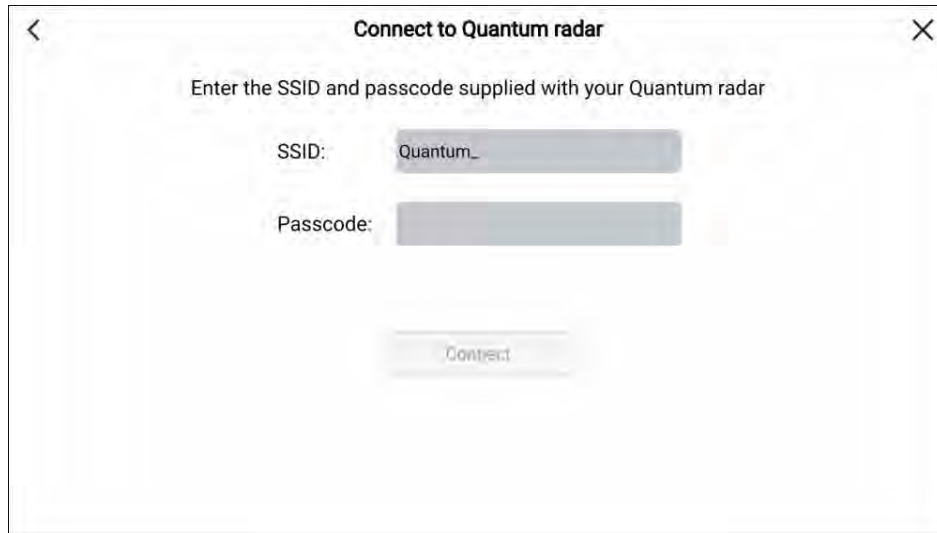

Important:

- Ensure that the SSID and Passcode are entered exactly as shown on the serial number label that was supplied with the Radar.
- The SSID is always made up of the word “**Quantum**”, followed by an underscore “_”, followed by the product’s 7 digit **serial number**, (e.g. **Quantum_1234567**).

7. Select [Connect].

The initial connection can take up to 2 minutes to complete. If the connection does not complete within 2 minutes, power cycle the Radar and repeat Steps 4 to 7.

8. Select [OK] from the Successful Connection pop-up.
9. Open a Radar application page.
10. Check that the reported Radar on the power / transmit pop-up is the Radar that you have just paired with.
11. If the correct Radar is reported, select [Tx] (Transmit).
12. If the reported Radar is not the Radar scanner you just paired with, select the correct Radar from the Radar application menu: [Menu > Select Radar:] and then select [Tx] (Transmit).

The Radar image can be displayed on all networked MFDs.

Changing Quantum radar channel

In rare circumstances Radar noise which cannot be eliminated using the Radar app’s [Sensitivity] settings may be fixed by changing the Radar’s internal wired adaptor channel.

Note:

- This feature requires Quantum 2 software version 2.50 (or later) / Quantum software version 2.44 (or later) and LightHouse™ 4 MFD software version 4.3.54 (or later).
- In the first instance you should try adjusting [Sensitivity] settings to eliminate the noise before changing the [Wired adaptor channel].

Follow the steps below to change the channel from your display:

1. Select the [Installation] tab from the Radar app menu: ([Menu > Settings > Installation]).
2. Select the [Wired Adapter Channel] field.

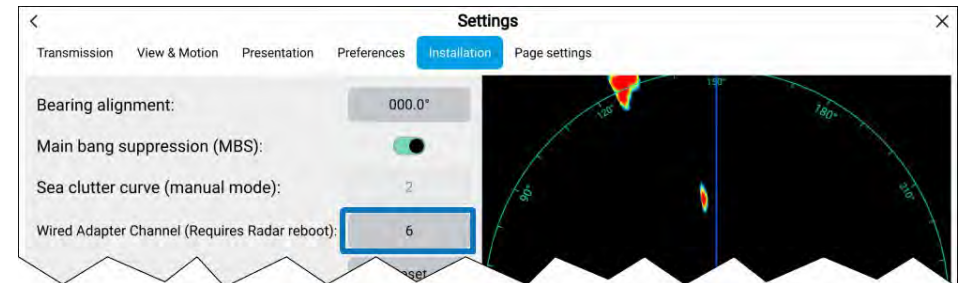

3. Change the channel to a different number.
4. Reboot the Radar scanner for the changes to take effect.

MFD access point connection when connected to Quantum Wi-Fi

Depending on you MFD variant, you may be restricted from connecting your MFD to a Wi-Fi access point, if a Quantum Radar that is connected using Wi-Fi is currently transmitting on the system.

a, c, e, gS Series and **Axiom** MFDs CANNOT connect to a Wi-Fi access point if there is a transmitting Wi-Fi connected Quantum Radar in the system. To connect these MFDs to a Wi-Fi access point the Quantum Radar must be placed in Standby mode first.

eS Series, Axiom Pro, Axiom Pro-s, Axiom XL, Axiom 2 Pro, Axiom 2 XL MFDs CAN connect to a Wi-Fi access point at the same time as being connected to a transmitting Wi-Fi connected Quantum Radar.

Standby and sleep modes for Wi-Fi connections

The radar scanner has 2 modes which may initially prevent you from successfully pairing the radar to an MFD via Wi-Fi, in the event that the Wi-Fi connection between the 2 devices is lost. These modes are part of the scanner's normal operation, but it's important to understand how these modes can potentially impact the pairing process.

- **Sleep mode** — If the connection to the MFD is lost while the scanner is in **Standby** mode, the scanner will switch to Sleep mode within 30 minutes. When the connection to the MFD is restored, return the scanner to Standby mode using the *[Power up Radar]* option on the MFD's Shortcut screen, accessible by momentarily pressing the MFD's Power button.
- **Standby mode** — If the connection to the MFD is lost while the scanner is in **Transmit** mode, the scanner will switch to Standby mode within 5 seconds. When the connection to the MFD is restored, return the scanner to Transmit mode using the *[Radar: Tx]* option on the MFD's Shortcut screen.

For a full description of all the Radar modes and associated on-screen status symbols, refer to the *Radar scanner status symbols* topic in the *Radar application* chapter of your MFD's Operations handbook.

Retain your Wi-Fi passcode

To connect to the Radar using Wi-Fi (wireless), you will need to know the unit's **SSID**, and **Passcode**.

Both the SSID and Passcode are provided on the serial number label on the underside of the unit, and on spare serial number labels supplied in the box. You may wish to make a separate note of this information and keep in a secure location. You should also keep the Radar scanner packaging in a safe place for future reference.

The following information is applicable only to Quantum units running software version 1.62 or later, and Quantum Doppler units running software version 2.43 or later:

In the event that you misplace the SSID and Passcode before the initial pairing, you can power on your Quantum unit and determine the SSID by reviewing all available Wi-Fi networks, using a smartphone, tablet or laptop PC. An unpaired Quantum unit will advertise its SSID periodically in a 10-second cycle. This may take up to 3 minutes.

Once you've obtained the SSID, the next step is to contact Raymarine® product support and servicing, who can then provide you with the passcode associated with your SSID. For further information on how to contact Raymarine® product support and servicing, refer to the following section: [p.74 — Raymarine product support and servicing](#)

Doppler data source requirements

Use of the Doppler Radar features requires the following data sources to be available on your system (e.g. connected to your multifunction display, via SeaTalkng® or NMEA 0183).

Required data sources

Data type	Example data source
COG (Course Over Ground)	GPS or GNSS receiver (MFD internal receiver or external receiver).
SOG (Speed Over Ground)	GPS or GNSS receiver (MFD internal receiver or external receiver).

Recommended data source

Data type	Example data source
HDG / HDT (True Heading)	Compass or Autopilot sensor providing Fastheading data (e.g. Evolution EV-1 / EV-2).

Note:

A heading data source is not essential for Doppler operation. However it will improve the performance of Doppler mode at slower speeds (< 15 knots), when tide set and leeway are present.

Radar target acquisition data source requirements

Radar target acquisition requires the following data sources to be available on your system (e.g. connected to your multifunction display, via SeaTalkng® or NMEA 0183).

Data type	Example data source
COG (Course Over Ground)	GPS or GNSS receiver (MFD internal receiver or external receiver).
SOG (Speed Over Ground)	GPS or GNSS receiver (MFD internal receiver or external receiver).
HDG / HDT (True Heading)	Compass or Autopilot sensor providing Fastheading data (e.g. Evolution EV-1 / EV-2).

Bearing alignment

The Radar bearing alignment ensures that Radar objects appear at the correct bearing relative to your vessel's bow. You should check the bearing alignment for any new installation.

Checking alignment

Align the bow with a stationary object between 0.25 and 2 NM away.

Reduce the gain to make the target as small as possible on the screen.

Note the position of the object on the Radar screen. If the target is not under the ship's heading marker (SHM), then bearing alignment adjustment is required.

Adjusting alignment

Adjust the *[Bearing alignment]* setting until the target object appears under the SHM.

[Bearing alignment] setting can be accessed from the *[Installation]* tab: *[Menu > Installation > Bearing alignment]*.

Note:

Heading (HDG) is displayed in the Radar application. Please be aware that bearing alignment refers to the **relative** bearing of **targets** to the vessel's bow using visual checks / traditional means.

Heading alignment

For systems with a compass providing heading data, it is important to ensure correct heading alignment.

Correct alignment ensures that the heading data provided by the compass matches the actual heading of the vessel. You should check the heading alignment for any new installation.

Checking alignment

Open the Chart application on the MFD and enable the Radar layer: *[Menu > Settings > Layers]*.

While the vessel is stationary (e.g. tied to a dock), orient the vessel's bow to a known bearing. Examples include:

- navigational range markers;
- a correctly calibrated fluid-filled compass onboard the vessel;
- other fixed marks from which an accurate heading can be obtained.

Alternatively, another option for checking heading alignment is to align the compass to the Course Over Ground (COG) data provided by a GPS receiver, while your vessel is underway in calm conditions where there is no tide.

Use the Radar and Chart displays to confirm the heading alignment. The on-screen icon representing your vessel should be oriented in exactly the same direction as the known bearing (e.g. navigational range marker).

Adjusting alignment

If the heading alignment is incorrect it may be necessary to re-calibrate the compass.

It is also possible that the compass is affected by sources of magnetic interference (such as marine pontoons, high current carrying cables, or electric motors). In this case it will be necessary to re-linearize the compass to compensate for magnetic interference. In extreme cases it may be necessary to re-locate the compass away from sources of magnetic interference.

For instructions on how to re-calibrate and/or re-linearize the compass, consult the compass manual.

11.2 Troubleshooting

The troubleshooting section provides possible causes and the corrective action required for common problems that are associated with the installation and operation of your product.

Before packing and shipping, all Raymarine® products are subjected to comprehensive testing and quality assurance programs. If you do experience problems with your product, this section will help you to diagnose and correct problems to restore normal operation.

If after referring to this section you are still having problems with your product, please refer to the *Technical support* section of this manual for useful links and Raymarine® Product Support contact details.

Troubleshooting procedure

Use the following table to identify problems and remedial actions.

Symptom	Action
No connection can be made to the scanner.	<p>Ensure the data cable (if used) is connected at both ends and is in good condition.</p> <p>If using a Wi-Fi (wireless) connection to the scanner unit, check that you have entered the correct Wi-Fi passcode for the SSID that matches your scanner. Both the SSID and Wi-Fi passcode are provided on the scanner packaging, and are also shown on the serial number label on the underside of the unit. For more information, refer to: p.65 — Retain your Wi-Fi passcode.</p>

Symptom	Action
	<p>Ensure power supply thermal breaker has not tripped or fuse has not blown. If necessary, reset breaker or replace fuse ONCE ONLY. If breaker keeps tripping or fuse keeps blowing, contact a Raymarine® authorized dealer for assistance.</p> <p>Ensure power supply maintains the correct voltage when the system is switched on.</p> <p>Ensure all products in the system have the correct software. Refer to www.raymarine.com/software for the latest software updates and the software update procedure for your product.</p> <p>If the Quantum™ Radome is connected to the multifunction display (MFD) via a RJ45 (SeaTalkhs®) or RayNet network switch, ensure that:</p> <ul style="list-style-type: none"> • All relevant equipment is correctly connected to the network switch. • The network switch power supply is satisfactory. • The network switch is in good condition. • Network cables are securely connected and in good condition.
Connection problems when switching from a wireless (Wi-Fi) to a wired (RayNet) connection.	<ol style="list-style-type: none"> 1. Upgrade MFD to latest software. 2. Upgrade Quantum radar to latest software. 3. Disable the MFD's Wi-Fi connection (refer to the MFD operations manual for instructions). 4. Power cycle the Quantum radar. 5. Open the Radar app on the MFD and confirm that the Radar is transmitting. 6. Re-enable the MFD's Wi-Fi connection.

Symptom	Action
---------	--------

Note:
For the latest software, refer to:
www.raymarine.com/software

Note:
If at some point in the future you decide to revert to the wireless (Wi-Fi) connection, refer to the pairing procedure: [p.59 – Pairing with a Quantum Radar using Wi-Fi](#).

Symptom	Action
---------	--------

Displayed bearing is different to the true bearing. Carry out the bearing alignment procedure described in the MFD Operations manual.

Note:
Heading (HDG) is displayed in the Radar application on the multifunction display (MFD). Please be aware that bearing alignment refers to the **relative** bearing of **targets** to the vessel's bow using visual checks / traditional means.

“Failed to update wired adaptor” error during Quantum software update

Note:
The following information does NOT apply to the Wi-Fi-only Quantum variant (E70344).

A small number of Quantum units fail to retain the unit’s serial number in the onboard memory. While this does not affect the normal operation or performance of the radar in any way, it is necessary to fix the issue for warranty and servicing purposes:

- If your MFD is running **LightHouse 3**, you can fix this issue by upgrading your Quantum unit to the latest available software version. Then power cycle the Quantum unit.
- If your MFD is running **LightHouse 2**, return the Quantum unit to Raymarine® Service to have the serial number restored.

Doppler troubleshooting

Doppler coloration is incorrect

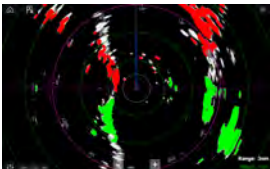
Example	Possible solution
<p>Stationary targets such as land are colored red or green when under way:</p> 	<ol style="list-style-type: none">1. Check bearing alignment, as described in this document and the MFD Operations manual.2. At low speeds (< 15 knots) and if a source of Heading data is available on the system, the compass alignment may be incorrect. Check the compass alignment, as described in the manual for the relevant Heading (compass) device.

Multiple Quantum Radars — more information

Only 1 (one) Quantum™ Radar scanner can be powered at any one time, per networked system.

- It is possible to have 1 Quantum™ + 1 NON-Quantum Raymarine Digital radar scanner powered at the same time, on the same networked system.
- It is NOT possible to have 2 Quantum™ Radar scanners connected via Wi-Fi powered at the same time, on the same networked system, or a single standalone display. While it is technically possible to power up 2 Quantum™ radar scanners connected via Wi-Fi separately to 2 standalone (non-networked) displays, or 2 displays which each belong to a different RayNet network, this configuration is NOT recommended. There may be Wi-Fi radio interference between 2 Quantum™ radars operating at the same time.
- It is NOT recommended to have 2 Quantum™ Radar scanners connected via RayNet powered at the same time, on the same networked system. However, it is possible to have 2 Quantum™ radar scanners connected via RayNet separately to 2 standalone (non-networked) displays, or 2 displays which each belong to a different RayNet network.
- It is NOT possible to have 2 Quantum™ Radar scanners powered at the same time, where one is connected via RayNet, and the other is connected via Wi-Fi, on the same networked system, or single standalone display. However, it is possible to have 2 Quantum™ radar scanners powered in this configuration if they are connected separately to 2 standalone

(non-networked) displays, or 2 displays which each belong to a different RayNet network.

Retain your Wi-Fi passcode

To connect to the Radar using Wi-Fi (wireless), you will need to know the unit's **SSID**, and **Passcode**.

Both the SSID and Passcode are provided on the serial number label on the underside of the unit, and on spare serial number labels supplied in the box. You may wish to make a separate note of this information and keep in a secure location. You should also keep the Radar scanner packaging in a safe place for future reference.

The following information is applicable only to Quantum units running software version 1.62 or later, and Quantum Doppler units running software version 2.43 or later:

In the event that you misplace the SSID and Passcode before the initial pairing, you can power on your Quantum unit and determine the SSID by reviewing all available Wi-Fi networks, using a smartphone, tablet or laptop PC. An unpaired Quantum unit will advertise its SSID periodically in a 10-second cycle. This may take up to 3 minutes.

Once you've obtained the SSID, the next step is to contact Raymarine® product support and servicing, who can then provide you with the passcode associated with your SSID. For further information on how to contact Raymarine® product support and servicing, refer to the following section: [p.74 — Raymarine product support and servicing](#)

Wi-Fi troubleshooting

Before troubleshooting problems with your Wi-Fi connection, ensure that you have followed the Wi-Fi location requirements guidance provided in the relevant installation instructions and performed a power cycle/reboot of the devices you are experiencing problems with.

Cannot find network

Possible cause	Possible solutions
Wi-Fi not currently enabled on devices.	Ensure Wi-Fi is enabled on both Wi-Fi devices and rescan available networks.
Some devices may automatically turn off Wi-Fi when not in use to save power.	Power cycle / reboot devices and rescan available networks.
Device not broadcasting.	<ol style="list-style-type: none">1. Try to enable broadcasting of the device's network using the Wi-Fi settings on the device you are trying to connect to.2. You may still be able to connect to the device, when it is not broadcasting, by manually entering the device's Wi-Fi Name / SSID and passphrase in the connection settings of the device you are trying to connect.
Devices out of range or signal being blocked.	Move devices closer together or, if possible remove the obstructions and then rescan available network.

Cannot connect to network

Possible cause	Possible solutions
Some devices may automatically turn off Wi-Fi when not in use to save power.	Power cycle/reboot devices and retry the connection.
Trying to connect to the wrong Wi-Fi network	Ensure you are trying to connect to the correct Wi-Fi network, the Wi-Fi network's name can be found in the Wi-Fi settings on the broadcasting device (the device that you are trying to connect to).

Possible cause	Possible solutions
Incorrect network credentials	Ensure you are using the correct passphrase, the Wi-Fi network's passphrase can be found in the Wi-Fi settings on the broadcasting device (the device that you are trying to connect to).
Bulkheads, decks and other heavy structure can degrade and even block the Wi-Fi signal. Depending on the thickness and material used it may not always be possible to pass a Wi-Fi signal through certain structures	<ol style="list-style-type: none">1. Try repositioning the devices so the structure is removed from the direct line of sight between the devices, or2. If possible use a wired connection instead.
Interference being caused by other Wi-Fi enabled or older Bluetooth enabled devices (Bluetooth and Wi-Fi both operate in the 2.4 GHz frequency range, some older bluetooth devices may interfere with Wi-Fi signals.)	<ol style="list-style-type: none">1. Change the Wi-Fi Channel of the device you are trying to connect to and retry the connection. You can use free Wi-Fi analyzer apps on your smart device to help you choose a better channel (channel with least traffic).2. Temporarily disable each wireless device in turn until you have identified the device causing the interference.

Possible cause	Possible solutions
<p>Interference caused by other devices that use the 2.4GHz frequency See list below of some common devices that use the 2.4GHz frequency:</p> <ul style="list-style-type: none"> • Microwave ovens • Fluorescent lighting • Cordless phones / baby monitors • Motion sensors 	<p>Temporarily switch off each device in turn until you have identified the device causing the interference, then remove or reposition the offending device(s).</p>
<p>Interference caused by electrical and electronic devices and associated cabling could generate an electromagnetic field which may interfere with the Wi-Fi signal.</p>	<p>Temporarily switch off each item in turn until you have identified the device causing the interference, then remove or reposition the offending device(s).</p>

Connection extremely slow and or keeps dropping out

Possible cause	Possible solutions
<p>Wi-Fi performance degrades over distance so products farther away will receive less network bandwidth. Products installed close to their maximum Wi-Fi range will experience slow connection speeds, signal drop outs or not being able to connect at all.</p>	<ul style="list-style-type: none"> • Move devices closer together. • For fixed installations such as a Quantum Radar, enable the Wi-Fi connection on an display installed closer to the device.
<p>Interference being caused by other Wi-Fi enabled or older Bluetooth enabled devices (Bluetooth and Wi-Fi both operate in the 2.4 GHz frequency range, some older bluetooth devices may interfere with Wi-Fi signals.)</p>	<ol style="list-style-type: none"> 1. Change the Wi-Fi Channel of the device you are trying to connect to and retry the connection. You can use free Wi-Fi analyzer apps on your smart device to help you choose a better channel (channel with least traffic). 2. Change the Quantum's Wi-Fi Channel via your master MFD. For more information, refer to: p.60 – Changing the Quantum Wi-Fi channel 3. Temporarily switch off each device in turn until you have identified the device causing the interference, then remove or reposition the offending device(s).
<p>Interference from devices on other vessels. When in close proximity to other vessels, for example, when moored up in a marina, many other Wi-Fi signals may be present.</p>	<ol style="list-style-type: none"> 1. Change the Wi-Fi Channel of the device you are trying to connect to and retry the connection. You can use free Wi-Fi analyzer apps on your smart device to help you choose a better channel (channel with least traffic). 2. Change the Quantum's Wi-Fi Channel via your master MFD. For more information, refer to: p.60 – Changing the Quantum Wi-Fi channel 3. If possible, move your vessel to a location with less Wi-Fi traffic.

Network connection established but no data

Possible cause	Possible solutions
Connected to the wrong network.	Ensure that your devices is connected to the correct network.
Device software incompatibility.	Ensure both devices are running the latest available software.
It may be possible that the device has become defective.	<ol style="list-style-type: none">1. Try updating software to a later version, or2. try reinstalling the software.3. Obtain new replacement device.

Mobile application running slowly or not at all

Possible cause	Possible solutions
Raymarine® app not installed	Install mobile app from relevant app store.
Raymarine® app version not compatible with display software	Ensure mobile app and display software are latest available versions.
Mobile apps not enabled on display	Enable “Viewing only” or “Remote Control” as required in the Mobile Apps setting on your display.

Wi-Fi connection recovery

You should use the SSID and Passcode supplied with your Radar to pair the Radar with your MFD. In the event that the original SSID and Passcode cannot be located follow the steps below to try and re-connect to your Radar.

1. The Radar will store the Wi-Fi credentials (SSID and passphrase) of the last 10 devices it has been paired with, this means that you can use the Wi-Fi credentials from a MFD that has previously been paired with the Quantum Radar. Enter the MFD’s Wi-Fi Name and Wi-Fi Passphrase on the Quantum Radar pairing page and try to connect. The MFD’s Wi-Fi Name (SSID) and Passphrase is located in the Wi-Fi menu: *(Homescreen > Set-up > System Set-up > Wireless Connections > Wi-Fi > Wi-Fi Sharing)*
2. The following information is applicable only to Quantum units running software version 1.62 or later, and Quantum Doppler units running software version 2.43 or later: In the event that you misplace the SSID and Passcode before the initial pairing, you can power on your Quantum

unit and determine the SSID by reviewing all available Wi-Fi networks, using a smartphone, tablet or laptop PC. An unpaired Quantum unit will advertise its SSID periodically in a 10-second cycle. This may take up to 3 minutes. Once you’ve obtained the SSID, the next step is to contact Raymarine® product support, who can then provide you with the passcode associated with your SSID. For further information on how to contact Raymarine® product support, refer to the following section: [p.74 — Raymarine product support](#)

CHAPTER 12: OPERATION

CHAPTER CONTENTS

- 12.1 Operation instructions — page 70

12.1 Operation instructions

For detailed operation instructions for your product, refer to the documentation that accompanies your display.

All product documentation is available to download from the Raymarine website: www.raymarine.com/manuals.

CHAPTER 13: MAINTENANCE

CHAPTER CONTENTS

- 13.1 Maintenance — page 72
- 13.2 Unit cleaning instructions — page 72

13.1 Maintenance

Once a year:

1. Power-off the Radar.
2. Remove one of the antenna-securing bolts and associated washers.
3. Clean the bolt and washers.
4. Ensure that the passage to the "breather" from the side of the unit is clear of sealant or paint, or other obstacles. For more information on the "breather", refer to: [p.37 – Mounting pre-requisite: "breather" holes](#).
5. Replace the bolt and associated washers.
6. Repeat steps 1 to 5 for all antenna-securing bolts.
7. Tighten all antenna-securing bolts to a torque of 15 N·m (11 lbf·ft).

Periodically, carry out these other maintenance tasks, with the Radar powered off:

- Ensure the antenna is firmly attached to the mounting surface.
- Check that any connected cables are in good condition and securely attached.
- Examine all cables for signs of chafing, cuts or other damage.



Warning: High voltage

This product contains high voltage. Do NOT remove covers or attempt to access internal components, unless specifically instructed in the documentation provided.

13.2 Unit cleaning instructions

The unit does not require regular cleaning. However, if you find it necessary to clean the unit, please follow the steps below:

1. Ensure power is switched off.
2. Wipe unit clean with a damp cloth.
3. If necessary, use a mild detergent solution to remove grease marks.

CHAPTER 14: TECHNICAL SUPPORT

CHAPTER CONTENTS

- 14.1 Raymarine product support and servicing — page 74
- 14.2 Viewing product information — page 75

14.1 Raymarine product support and servicing

Raymarine provides a comprehensive product support service, as well as warranty, service, and repairs. You can access these services through the Raymarine website, telephone, and e-mail.

Product information

If you need to request service or support, please have the following information to hand:

- Product name.
- Product identity.
- Serial number.
- Software application version.
- System diagrams.

You can obtain this product information using diagnostic pages of the connected display.

Servicing and warranty

Raymarine offers dedicated service departments for warranty, service, and repairs.

Don't forget to visit the Raymarine website to register your product for extended warranty benefits: <https://www.raymarine.com/en-us/support/product-registration>

United Kingdom (UK), EMEA, and Asia Pacific:

- E-Mail: emea.service@raymarine.com
- Tel: +44 (0)1329 246 932

United States (US):

- E-Mail: rm-usrepair@flir.com
- Tel: +1 (603) 324 7900

Web support

Please visit the "Support" area of the Raymarine website for:

- **Manuals and Documents** — <http://www.raymarine.com/manuals>
- **Technical support forum** — <https://raymarine.custhelp.com/app/home>
- **Software updates** — <http://www.raymarine.com/software>

Worldwide support

United Kingdom (UK), EMEA, and Asia Pacific:

- Help desk: <https://raymarine.custhelp.com/app/home>
- Tel: +44 (0)1329 246 777

United States (US):

- Help desk: <https://raymarine.custhelp.com/app/home>
- Tel: +1 (603) 324 7900 (Toll-free: +800 539 5539)

Australia and New Zealand (Raymarine subsidiary):

- E-Mail: aus.support@raymarine.com
- Tel: +61 2 8977 0300

France (Raymarine subsidiary):

- E-Mail: support.fr@raymarine.com
- Tel: +33 (0)1 46 49 72 30

Germany (Raymarine subsidiary):

- E-Mail: support.de@raymarine.com
- Tel: +49 40 237 808 0

Italy (Raymarine subsidiary):

- E-Mail: support.it@raymarine.com
- Tel: +39 02 9945 1001

Spain (Authorized Raymarine distributor):

- E-Mail: sat@azimut.es
- Tel: +34 96 2965 102

Netherlands (Raymarine subsidiary):

- E-Mail: support.nl@raymarine.com
- Tel: +31 (0)26 3614 905

Sweden (Raymarine subsidiary):

- E-Mail: support.se@raymarine.com
- Tel: +46 (0)317 633 670

Finland (Raymarine subsidiary):

- E-Mail: support.fi@raymarine.com
- Tel: +358 (0)207 619 937

Norway (Raymarine subsidiary):

- E-Mail: support.no@raymarine.com

- Tel: +47 692 64 600

Denmark (Raymarine subsidiary):

- E-Mail: support.dk@raymarine.com
- Tel: +45 437 164 64

Russia (Authorized Raymarine distributor):

- E-Mail: info@mikstmarine.ru
- Tel: +7 495 788 0508

2. You can view further information about your display, or view information about products networked using SeaTalkhs[®] and SeaTalkng[®] / NMEA 2000, by selecting the [Network] tab, then:
 - i. to display detailed software information and your display's network IP address, select your display from the list.
 - ii. to display detailed diagnostics information for all products, select [Product info] from the [Diagnostics] pop over menu.

14.2 Viewing product information

Use the [Settings] menu to view hardware and software information about your display, and connected products.

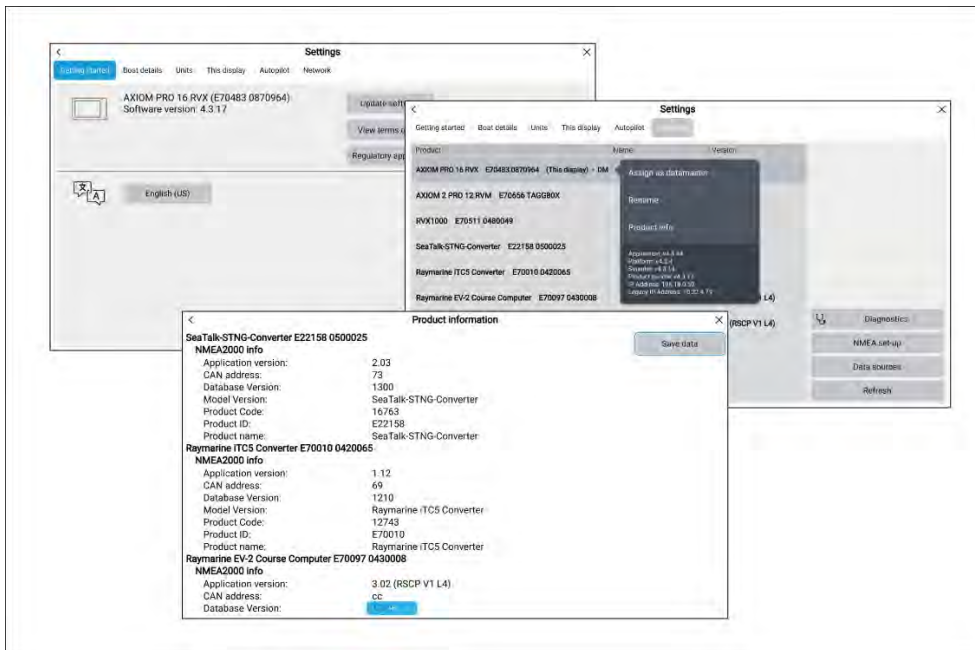

1. Select [Settings], from the Homescreen.
The [Getting started] menu contains hardware and software information for your display.

CHAPTER 15: TECHNICAL SPECIFICATION

CHAPTER CONTENTS

- 15.1 Conformance specification — page 77
- 15.2 Physical specification — page 77
- 15.3 Power specification — page 77
- 15.4 Environmental specification — page 77
- 15.5 Range — page 77
- 15.6 Transmitter specification — page 77
- 15.7 Receiver specification — page 78
- 15.8 Antenna specification — page 78
- 15.9 Doppler specification — page 78

15.1 Conformance specification

Specification	
International:	EN 60945 : 2002 IEC 60945 : 2002-08
USA:	47CFR FCC Part 2 & Part 80 Certificate of Approval
Canada:	RSS238 Iss. 1 Technical Acceptance Certificate
European Union & EFTA:	Radio Equipment Directive 2014/53/EU Certificate of Opinion
Australia / New Zealand:	ACMA Declaration of Conformity Compliance level 3

15.2 Physical specification

Specification	
Diameter:	541.0 mm (21.3 in)
Height:	209.5 mm (8.25 in)
Weight:	5.6 kg (12.3 lbs)

15.3 Power specification

Specification	
Supply voltage:	Either 12 V dc or 24 V dc nominal Minimum: 10.8 V dc Maximum: 31.2 V dc
Power consumption:	Transmit mode (maximum): 17 W Standby mode: 7 W Sleep mode (applies only to radars connected via Wi-Fi): 2 W
Inline fuse rating:	5 A
Thermal breaker rating:	3 A

15.4 Environmental specification

Specification	
Waterproof rating:	IPx6
Operating temperature range:	-10° C (14° F) to +55° C (131° F)
Storage temperature range:	-25° C (-13° F) to +70° C (+158° F)
Additional storage conditions:	Store upright; do not block vents on underside of unit
Humidity:	Up to 95% at 35° C (95° F)
Maximum wind speed:	100 kts

15.5 Range

Specification	
Range scales:	1/16, 1/8, 1/4, 3/8, 1/2, 3/4, 1, 1.5, 2, 3, 4, 6, 8, 12, 16, and 24 nautical miles

15.6 Transmitter specification

Specification	
Type:	X-band solid-state transmitter with pulse compression technology
Transmit frequency:	9354 MHz to 9446 MHz
Peak power output:	20 W
Duplexer:	Circulator
Pulse widths (3 dB):	40 ns to 14.7 µs
CHIRP lengths:	400 ns to 22 µs
Pulse repetition frequency:	920 Hz to 5900 Hz
CHIRP bandwidth:	Up to 32 MHz
Standby mode:	Scanner rotation - OFF Scanner transmission - OFF Wi-Fi link - ON

15.7 Receiver specification

Specification

IF frequency:	26 MHz
Noise figure:	< 4 dB

15.8 Antenna specification

Specification

Type:	Patch Array
Beamwidth (nominal):	Horizontal: 4.9° Vertical: 20°
Polarization:	Horizontal
Rotation speed:	24 RPM nominal

15.9 Doppler specification

Specification

Target tracking:	Tracking of 25 simultaneous Radar targets.
Target filtering:	<i>True Motion</i> mode identifies only those objects that are moving relative to the vessel.

CHAPTER 16: SPARES AND ACCESSORIES

CHAPTER CONTENTS

- 16.1 Quantum Radar accessories — page 80
- 16.2 RayNet to RayNet cables and connectors — page 81
- 16.3 RayNet to RJ45, and RJ45 (SeaTalkhs) adapter cables — page 82

16.1 Quantum Radar accessories

The following accessories are available for the Quantum™ Radar scanner:

Item	Part number
10 m (32.8 ft.) Quantum™ power cable	A80309
15 m (49.2 ft.) Quantum™ power cable	A80369
5 m (16.4 ft.) Quantum™ data cable	A80274
10 m (32.8 ft.) Quantum™ data cable	A80275
15 m (49.2 ft.) Quantum™ data cable	A80310
25 m (82.0 ft.) Quantum™ data cable	A80311
Quantum™ Y-adapter cable	A80308
RayNet cable joiner	A80162

Note:

For more information on additional RayNet cables and adapters, refer to the following sections:

- [p.81 — RayNet to RayNet cables and connectors](#)
- [p.82 — RayNet to RJ45, and RJ45 \(SeaTalkhs\) adapter cables](#)

16.2 RayNet to RayNet cables and connectors

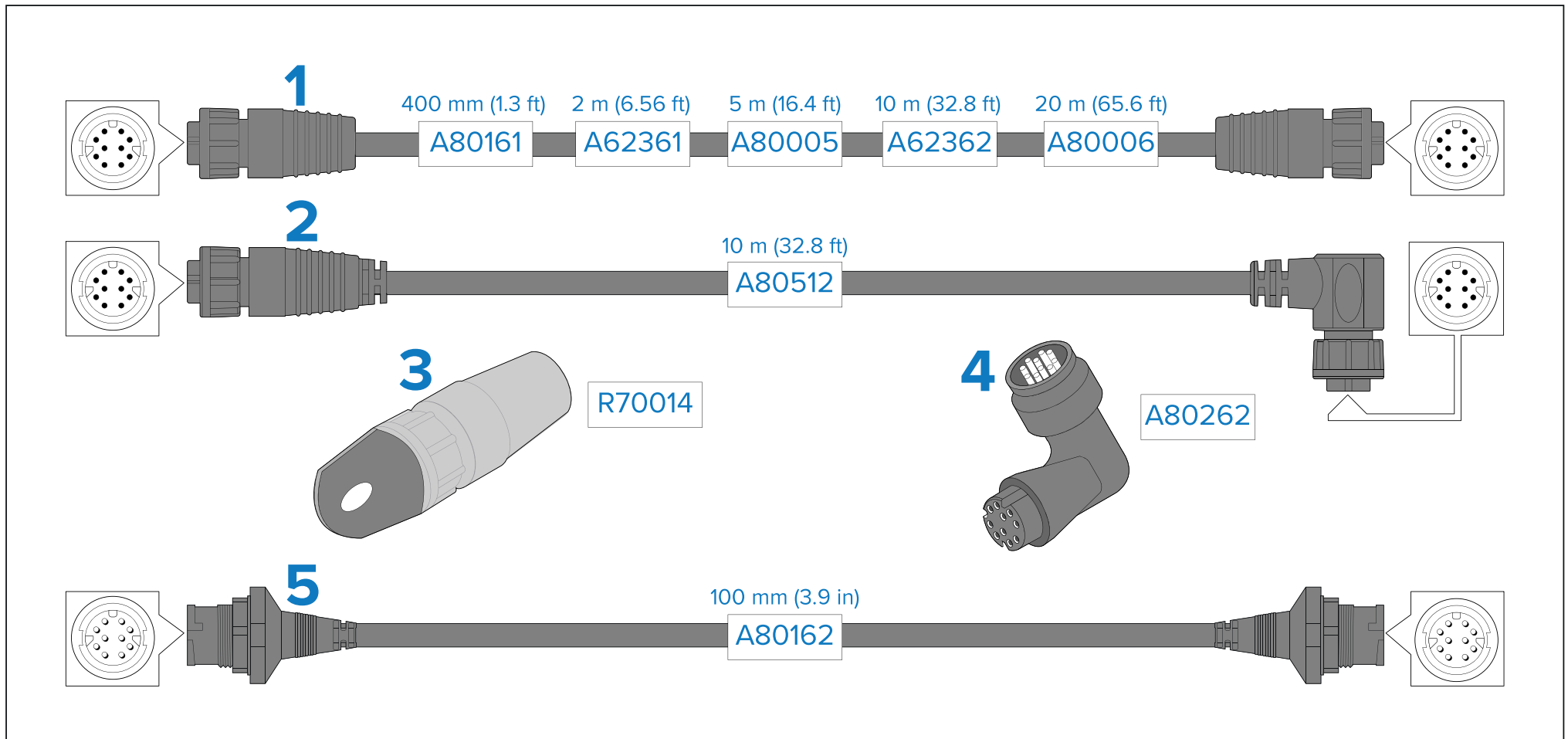

1. Standard RayNet connection cable with a RayNet (female) socket on both ends.
2. Right-angle RayNet connection cable with a straight RayNet (female) socket on one end, and a right-angle RayNet (female) socket on the other. Suitable for connecting at 90° (right angle) to a device, for installations where space is limited.
3. RayNet cable puller (5 pack).
4. RayNet to RayNet right-angle coupler / adapter. Suitable for connecting RayNet cables at 90° (right angle) to devices, for installations where space is limited.
5. Adapter cable with a RayNet (male) plug on both ends. Suitable for joining (female) RayNet cables together for longer cable runs.

16.3 RayNet to RJ45, and RJ45 (SeaTalkhs) adapter cables

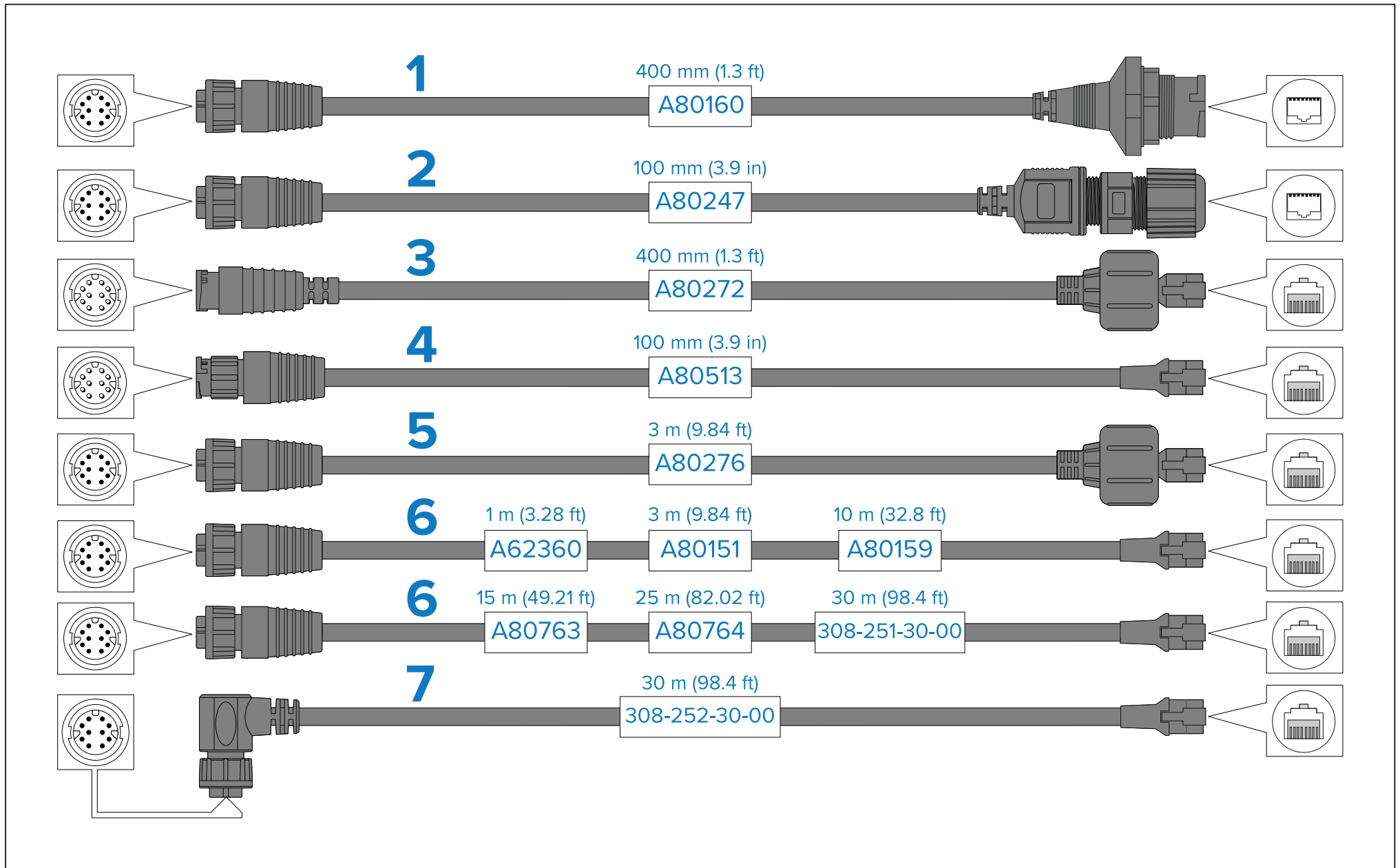

1. Adapter cable with a RayNet (female) socket on one end, and a waterproof (female) RJ45 (SeaTalkhs[®]) socket on the other end, accepting the following cables with an RJ45 (SeaTalkhs[®]) waterproof locking (male) plug:
 - A62245 (1.5 m).
 - A62246 (15 m).
2. Adapter cable with a RayNet (female) socket on one end, and a waterproof (female) RJ45 (SeaTalkhs[®]) socket on the other end, along with a locking gland for a watertight fit.
3. Adapter cable with a RayNet (male) plug on one end, and an RJ45 (SeaTalkhs[®]) waterproof (male) plug on the other end.
4. Adapter cable with a RayNet (male) plug on one end, and an RJ45 (male) plug on the other end.
5. Adapter cable with a RayNet (female) socket on one end, and an RJ45 (SeaTalkhs[®]) waterproof (male) plug on the other end.
6. Adapter cable with a RayNet (female) socket on one end, and an RJ45 (male) plug on the other end.
7. Adapter cable with a right-angled RayNet (female) socket on one end, and an RJ45 (male) plug on the other end.

Appendix A Licensing issuing authorities

The following table lists the relevant issuing authority for licences in each region, along with a link to the relevant website. Many authorities allow you to apply for a license online.

Country & regulatory authority	Website
<u>Argentina (AR):</u> Ente Nacional de Comunicaciones	http://www.enacom.gov.ar
<u>Australia (AU):</u> Australian Communications and Media Authority	http://www.acma.gov.au/
<u>Austria (AT):</u> Austrian Regulatory Authority for Broadcasting and Telecommunications	http://www.rtr.at
<u>Belgium (BE):</u> Belgian Institute for Postal services and Telecommunications (BIPT)	http://www.bipt.be
<u>Brazil (BR):</u> Agencia Nacional de Telecomunicacoes	http://www.anatel.gov.br
<u>Bulgaria (BG):</u> Communications Regulation Commission	http://www.crc.bg
<u>Canada (CA):</u> Industry Canada	https://www.ic.gc.ca/eic/site/smt-gst.nsf/eng/home
<u>China (ZH):</u> Ministry of Information Industry	http://www.mii.gov.cn
<u>Costa Rica (CR):</u> Superintendencia de Telecomunicaciones	http://sutel.go.cr

Country & regulatory authority	Website
<u>Croatia (HR):</u> Croatian Post and Electronic Communications Agency	http://www.hakom.hr/default.aspx?id=7
<u>Cyprus (CY):</u> Office of Electronic Communications & Postal Regulation	http://www.ocecpr.org.cy/nqcontent.cfm?a_id=767&tt=ocecpr&lang=gr
<u>Czech Republic (CZ):</u> The Czech Telecommunication Office	http://www.ctu.eu/main.php?pageid=178
<u>Denmark (DK):</u> Danish Energy Agency	https://ens.dk/en
<u>Estonia (EE):</u> Estonian Competition Authority	http://www.konkurentsiamet.ee/?lang=en
<u>Finland (FI):</u> Finnish Communications Regulatory Authority	http://www.ficora.fi/en
<u>France (FR):</u> Autorité de Régulation des Communications Électroniques et des Postes	http://www.arcep.fr
<u>Germany (DE):</u> Bundesnetzagentur	http://www.bundesnetzagentur.de
<u>Greece (EL):</u> Hellenic Telecommunications and Post Commission	http://www.eett.gr/opencms/opencms/EETT_EN/index.html
<u>Holland (NL):</u> Autoriteit Consument & Markt	https://www.acm.nl/nl
<u>Hong Kong (HK):</u> Office of Communications Authority	http://www.ofca.gov.hk

Country & regulatory authority	Website
<u>Hungary (HU):</u> National Media and Infocommunication Authority	http://www.nmhh.hu
<u>Iceland (IS):</u> Post and Telecom Administration	http://www.pfs.is/default.aspx?cat_id=101
<u>Indonesia (ID):</u> Indonesian Telecommunications Regulatory Authority	http://www.brti.or.id
<u>Ireland (IE):</u> Commission for Communications Regulation	http://www.comreg.ie
<u>Isle of Man (IM):</u> Communications Commission	http://www.gov.im/government/boards/cc.xml
<u>Italy (IT):</u> Autorità per le Garanzie nelle Comunicazioni	http://www.agcom.it
<u>Jamaica (JM):</u> Spectrum Management Authority	http://www.sma.gov.jm
<u>Japan (JP):</u> Ministry of Internal Affairs and Communications	http://www.soumu.go.jp/english/index.html
<u>Korea, South (KR):</u> Korea Communications Commission	http://eng.kcc.go.kr
<u>Lichtenstein (LI):</u> Office for Communications	http://www.llv.li/amtsstellen/llv-ak-english-page.htm
<u>Lithuania (LT):</u> Communications Regulatory Authority	http://www.rtt.lt/en/home.html

Country & regulatory authority	Website
<u>Luxembourg (LU):</u> Institut luxembourgeois de régulation	http://www.ilr.public.lu
<u>Latvia (LV):</u> Elektronisko sakaru direkcija	https://www.vases.lv/lv/content/juras-sakaru-atlaujas
<u>Malaysia (MY):</u> Malaysian Communications and Multimedia Commission	http://www.mcmc.gov.my
<u>Malta (MT):</u> Malta Communications Authority	http://www.mca.org.mt
<u>Mexico (MX):</u> Instituto Federal de Telecomunicaciones	http://www.ift.org.mx
<u>New Zealand (NZ):</u> Commerce Commission of New Zealand	http://www.comcom.govt.nz
<u>Norway (NO):</u> Norwegian Communications Authority	http://www.nkom.no
<u>Panama (PA):</u> Autoridad Nacional de los Servicios Públicos	http://www.asep.gob.pa/default.asp
<u>Poland (PL):</u> Prezes Urzędu Komunikacji Elektronicznej	http://www.uke.gov.pl
<u>Portugal (PT):</u> Autoridade Nacional de Comunicações	https://www.anacom.pt

Country & regulatory authority	Website
<u>Romania (RO):</u> National Authority for Management and Regulation in Communications of Romania	http://www.ancom.org.ro/en
<u>Russia (RU):</u> Ministry of Telecom and Mass Communications of the Russian Federation	https://minsvyaz.ru/en
<u>Saudi Arabia (SA):</u> Communications and Information Technology Commission (Saudi Arabia)	http://www.citc.gov.sa
<u>Singapore (SG):</u> Info-communications Media Development Authority of Singapore	https://www.imda.gov.sg
<u>Slovenia (SI):</u> Agency for communication networks and services of the Republic of Slovenia	http://www.akos-rs.si/akos-ang
<u>Slovakia (SK):</u> Telecommunications Regulatory Authority of the Slovak Republic	http://www.teleoff.gov.sk/index.php?ID=9
<u>South Africa (ZA):</u> Independent Communications Authority of South Africa	http://www.icasa.org.za
<u>Spain (ES):</u> Comisión Nacional de los Mercados y la Competencia	https://www.cnmc.es/en
<u>Sweden (SE):</u> Swedish Post and Telecom Authority	http://www.pts.se

Country & regulatory authority	Website
<u>Switzerland (CH):</u> Office fédéral de la communication	http://www.bakom.admin.ch/themen/frequenzen/00689/01563/index.html?lang=fr
<u>Taiwan (TW):</u> National Communications Commission	http://www.ncc.gov.tw/english/index.aspx
<u>Thailand (TH):</u> National Broadcasting and Telecommunications Commission	http://nbt.go.th/wps/portal/NTC/eng
<u>Turkey (TR):</u> Information And Communication Technologies Authority	http://eng.btk.gov.tr
<u>United Arab Emirates (AE):</u> Telecommunications Regulatory Authority	http://www.tra.ae
<u>United Kingdom and Northern Ireland (UK (NI)):</u> OFCOM	http://www.ofcom.org.uk
<u>United States (US):</u> FCC	https://www.fcc.gov/bureau-divisions/mobility-division/ship-radio-stations#block-menu-block-4

Appendix B Ethernet (IPv4) networking of Raymarine devices with third-party products

Raymarine uses a custom Ethernet (IPv4) networking configuration. Use the following information to help you understand how Raymarine's Ethernet (IPv4) implementation interacts with third-party Ethernet (IPv4) devices on your vessel, such as routers, switches, Access Points (APs) etc.

Important:

- Third-party networking products such as routers, switches, and Access Points (APs) *may* work when connected to Raymarine networks, when configured correctly. However, correct operation is not guaranteed. It's important to refer to the instructions provided by the relevant third-party device manufacturer, to ensure that your intended use of a third-party device is consistent with the device's design intent.
- Raymarine does not warrant that Raymarine products are compatible with products manufactured by any person or entity other than Raymarine.
- When using third-party products in your Raymarine electronics network, you should be aware of, and understand, the concepts and limitations described in the following Disclaimer: [p.10 — Disclaimer](#)

Overview

- Ethernet (IPv4) networking is a method for interconnecting multiple electronic devices, allowing many devices to function in a network and share data using only a single RJ45 or RayNet connection for each device.
- In order to function correctly, every Ethernet (IPv4) device (whether Raymarine or third-party) must have a unique IP address allocated to it, and it must not conflict with that of any other device.
- IPv4 addresses can be centrally-allocated to devices either **automatically**, using a method known as *DHCP* (Dynamic Host Configuration Protocol), or **manually** (i.e. allocated a static IP address). The most common method for allocating IPv4 addresses on vessel electronics networks is *DHCP*. In this configuration, the *server* device is known as a *DHCP server*.

Client / Server device	Example(s)
Raymarine IPv4 DHCP client	<ul style="list-style-type: none">• Radar scanner (e.g. <i>Quantum</i>)• Sonar module (e.g. <i>CP470</i>)• IP camera (e.g. <i>CAM300</i>)
Raymarine IPv4 DHCP server and self-addressing device	<ul style="list-style-type: none">• Multifunction display (MFD / Chartplotter), running LightHouse 3 or LightHouse 4 (e.g. <i>Axiom</i>)• Marine Router (e.g. <i>YachtSense Link Router</i>)
Third-party IPv4 DHCP client	IP camera
Third-party IPv4 DHCP server	<ul style="list-style-type: none">• Router• Switch• Access Point (AP)

Note:

The DHCP server maintains a pool of IP addresses and “leases” an address to any DHCP-enabled client, when the client device first powers up and announces its presence on the network. Because the IP addresses are dynamic (leased) rather than static (permanently assigned), addresses no longer in use are automatically returned to the DHCP server's pool, for subsequent reallocation.

It's also possible to have multiple DHCP servers issuing addresses on an IPv4 network, but to avoid addressing conflicts, all DHCP servers must be carefully configured to only allocate IP addresses in distinct address ranges. The *subnet mask* must also be carefully configured, to ensure that devices can correctly communicate with one another.

Implementation

- Raymarine Ethernet (IPv4) devices expect to use a private **Raymarine IPv4 network**, which is designed to be internal to the vessel only. Raymarine has carefully chosen a specific IP address range (**198.18.0.0/21**) to ensure that it does not interfere with any external IP address ranges, or other legacy and real-world addressing constraints (including but not limited to marina Wi-Fi networks).

Note: Raymarine's IP address range is for **local traffic** within the **vessel's private Raymarine network only**, and does NOT traverse across Raymarine products to external networks, or to the Internet.

- In a Raymarine Ethernet (IPv4) network, IP addresses are self-allocated by certain Raymarine equipment in the following range: **198.18.0.32 to 198.18.3.255** (inclusive). **You must avoid placing any devices in this range using manual (static) IP addresses.**
- Whether your network includes only Raymarine Ethernet (IP) devices, or a mixture of Raymarine and third-party Ethernet (IPv4) devices, you have 3 options for configuring the Ethernet (IPv4) network and managing the IP addresses for your devices:
 1. Use a Raymarine device as the sole DHCP server to allocate IP addresses automatically to all Raymarine and third-party Ethernet (IPv4) devices on the network. **For the purposes of simplicity and reliability, this is the recommended option for most vessels.** The following Raymarine devices can act as DHCP servers:
 - a. **Raymarine multifunction display (MFD)** / Chartplotter, running LightHouse 3 or LightHouse 4; or
 - b. **Raymarine YachtSense Link Router**

Note: If both a Raymarine MFD **and** YachtSense Link Router are present in the same network, the YachtSense Link Router **MUST** be configured as the DHCP server for that network. To facilitate this, the Raymarine MFD's DHCP setting defaults to *Automatic* as standard. On power up, if the YachtSense Link is detected in the RayNet system, any MFDs in the network will disable their own *DHCP Server*, to permit the YachtSense Link to manage the network's IP addresses. Only Raymarine MFDs running **LightHouse 4** are compatible with the YachtSense Link Router. Additionally, the most recent versions of the LightHouse 4 and YachtSense Link software must be used.

2. Use a third-party Ethernet (IPv4) device (such as a router or Access Point) to allocate IP addresses automatically, as a sole *DHCP server*. To do this, refer to the *Configuring a third-party router as DHCP server* section, below.

Note: Any Raymarine LightHouse 3 or LightHouse 4 MFDs will still self-allocate their own IP address, even if a third-party DHCP server is being used to allocate IP addresses to other Raymarine or non-Raymarine *DHCP client* devices (Camera, Radar, Sonar etc.) on the network.

3. Manually configure static IP addresses for your devices. The address range **198.18.0.32 to 198.18.3.255** (inclusive) is used by Raymarine equipment, and any other third-party equipment on the network should not be set to a static IP address in this range. It should instead be set elsewhere in the 198.18.0.0/21 range.

Adding third-party devices to your Raymarine Ethernet (IP) network

- It is recommended that any third-party products connecting to a Raymarine Ethernet (IPv4) network (e.g., a third-party IP camera) are configured as DHCP clients, so that they automatically get allocated a correct IP address within the range used by the **Raymarine IPv4 network**. If this is not possible, (for example, in the scenario that your third-party IP Camera requires a static IP address), you should configure the product to have a static IP address within the following range: **198.18.0.1 to 198.18.0.31** (inclusive).
- Any third-party router in your network should be performing IPv4 *Network Address Translation* (NAT) from the private address to another one on an upstream interface.

Configuring a third-party router as DHCP server

In the scenario that you wish to use a third-party DHCP server to allocate the IP addresses for your vessel's IPv4 network, use the following information to help you configure the third-party DHCP server to work with Raymarine Ethernet (IPv4) client devices:

1. Configure the third-party DHCP server / router to use Raymarine's subnet details, which are as follows:
 - a. Set the DHCP server's IP address to **198.18.0.1**
 - b. Set the *netmask* to /21, i.e. **255.255.248.0**
 - c. Set the DHCP range from **198.18.4.0 to 198.18.7.254** (inclusive). If this is not possible, ensure that the address range is smaller than this (but within the range of **198.18.4.0 to 198.18.7.254** (inclusive)).

- d. The address range **198.18.0.32 to 198.18.3.255** (inclusive) is used by Raymarine equipment, and therefore you must ensure that any other third-party equipment on the network is NOT set to a static IP address in this range.
2. It may be necessary to set the DHCP setting for **all** of the MFDs on the vessel to *[Off]*. However, the default option (*[Auto]*) will likely work fine in many cases. If for any reason the third-party DHCP server starts up after the MFD starts up, the user should manually set the MFD's DHCP switch to *[Off]*. This is because, when the MFD starts up, its DHCP *[Auto]* feature tries to detect if another DHCP server is already present on the network.
3. In case of failure of the third-party device, the MFDs can be easily configured to be the DHCP server again, by setting the MFD's DHCP setting back to *[Auto]*.

Adding third-party Wi-Fi Access Points / Wi-Fi routers to your Raymarine Ethernet (IPv4) network

- There is a large volume of multicast IPv4 traffic on the Raymarine Ethernet (IPv4) network. Many consumer Wi-Fi Access Points / Wi-Fi routers simply bridge all multicast traffic from the Ethernet interface to the Wi-Fi interface when there are connected Wi-Fi clients. This will result not only in poor Wi-Fi performance but also in a reduction of usable Wi-Fi spectrum to other Wi-Fi users and vessels in the vicinity. If using a third-party Wi-Fi Access Point or Wi-Fi router, Raymarine recommends that *IGMP Snooping* is enabled on the third-party device, and additional checks are performed, in order to ensure that your device is not bridging any unexpected multicast traffic to its Wi-Fi interface from the Raymarine Ethernet (IPv4) network.
- Raymarine's YachtSense Link Router is pre-configured with IGMP Snooping enabled, and therefore does not bridge internal multicast traffic on the wired network to the Wi-Fi network. No additional configuration is required in this respect.

Index

A

Accessories	80
Network adapter cables	82
Network cables	81
RayNet cables	81
ARPA	
Data source requirements	18, 62

B

Box contents	24
--------------------	----

C

Cable	
Bend radius	44
Protection	44
Routing	44
Security	44
Strain relief	44
Cable routing (platform mount)	46
Cable routing (pole mount)	47
Cabling	
Circuit isolation	44
Chart	
Heading alignment	62
Circuit isolation	44
Cleaning	72
Compass safe distance	11
Compatible MFDs / Chartplotters	19
Connections	
Battery	56
Distribution panel	56
Power	55
Wi-Fi	59
Contact details	74

D

Diagnostics	75
Dimensions	27
Documentation	
Operation instructions	13, 15, 70
Doppler	
Data source requirements	18, 61
Overview	17
Specification	78
Troubleshooting	65

E

Electromagnetic Compatibility	11
EMC, See Electromagnetic Compatibility	
Ethernet	88

F

Fuse rating	24, 55
Fuse requirement	24

I

Incompatible multifunction displays	20
Installation	
Best practice	57
Mounting	36, 38
Multiple radar scanners	65
Tools required	37
Wireless considerations	10, 30, 33
Interference	11
See <i>also</i> Compass safe distance	
IP address	75
IP networking	88

L

Licensing	
Issuing authorities	85
Requirement	12
Location requirements	

Wi-Fi.....	30
Wireless	33
Wireless interference.....	33

M

Maintenance.....	10
MFD	
Compatibility.....	19
MMSI	
Issuing authorities.....	85
Mounting	36

N

Network	
cables	82
Network connections	
Network switch	53
Wi-Fi.....	52
Wired (RayNet).....	51
Networking (IP)	
Overview.....	88

O

Operation instructions	13, 15, 70
------------------------------	------------

P

Parts supplied.....	24
Platform mounting	46
Pole mounting	47
Power	
Battery connection.....	56
Cable extension	57
Connection	55
Distribution	55
Distribution panel.....	56
Fuse and breaker ratings.....	24, 55
Fuses	24
Grounding.....	55, 57

Sharing a breaker	56
Power cable extension	57
Product information	75
Product overview.....	17
Product recycling (WEEE)	12
Product support.....	74

R

Radar	
Bearing alignment.....	62
Heading alignment	62
Radar, required additional system components.....	17
RayNet.....	88
cables	81–82
RJ45	
cables	82

S

SeaTalkhs	
cables	82
Service Center.....	74
Servicing.....	10
Software updates	21, 34
Suppression ferrites	44
See <i>also</i> EMC	
System diagram.....	21

T

Target acquisition	
Data source requirements	18, 62
Target tracking	78
Technical specification	76
Antenna specification	78
Conformance specification	77
Doppler.....	78
Environmental specification.....	77
Physical specification.....	77
Power specification.....	77
Range	77

Receiver specification.....	78
Transmitter specification.....	77
Technical support.....	74
Thermal breaker rating.....	24, 55
Troubleshooting	63
Typical system examples	21

U

Upgrading, software.....	21
--------------------------	----

W

Warranty	12, 74
WEEE Directive.....	12
What's in the box.....	24



Raymarine (UK / EU)

Marine House, Cartwright Drive,
Fareham, Hampshire.
PO15 5RJ.
United Kingdom.

Tel: (+44) (0)1329 246 700

www.raymarine.co.uk

Raymarine (US)

110 Lowell Road,
Hudson, NH 03051.
United States of America.

Tel: (+1) 603-324-7900

www.raymarine.com



Raymarine®