



AIS700

CLASS B AIS TRANSCEIVER & SPLITTER

INSTALLATION INSTRUCTIONS

English (en-US)

Date: 09-2023

Document number: 87326 (Rev 6)

© 2023 Raymarine UK Limited

Raymarine®

Legal notices

Trademark and patents notice

Raymarine, Tacktick, Pathfinder, ClearPulse, Truzoom, SeaTalk, SeaTalk^{hs}, SeaTalkng, and **Micronet**, are registered or claimed trademarks of Raymarine Belgium.

FLIR, Fishidy, Fishing Hot Spots, YachtSense, DockSense, LightHouse, RangeFusion, DownVision, SideVision, RealVision, HyperVision, Dragonfly, Element, Quantum, Axiom, Instalert, Infrared Everywhere, The World's Sixth Sense and **ClearCruise** are registered or claimed trademarks of FLIR Systems, Inc.

All other trademarks, trade names, or company names referenced herein are used for identification only and are the property of their respective owners.

This product is protected by patents, design patents, patents pending, or design patents pending.

Fair Use Statement

You may print no more than three copies of this manual for your own use. You may not make any further copies or distribute or use the manual in any other way including without limitation exploiting the manual commercially or giving or selling copies to third parties.

CONTENTS

CHAPTER 1 IMPORTANT INFORMATION	8	CHAPTER 3 PRODUCT AND SYSTEM OVERVIEW	14
Safety warnings	8	3.1 AIS overview	15
Product warnings	8	3.2 Compatible Raymarine® displays.....	16
Regulatory notices	9	Axiom 2 multifunction displays.....	16
RF safety notice	9	Axiom multifunction displays	16
Compliance Statement (Part 15.19)	9	gS / eS / aSeries / eSeries / cSeries	
FCC Interference Statement (Part 15.105		multifunction displays	17
(b))	9	I70 / i70s instrument displays	17
Innovation, Science and Economic		Legacy multifunction displays.....	17
Development Canada (ISED).....	9	Compatible third-party displays	18
Innovation, Sciences et Développement			
économique Canada (Français)	10	CHAPTER 4 PARTS SUPPLIED	19
AIS licensing and MMSI.....	10	4.1 Parts supplied	20
Declaration of conformity	10	4.2 Inline fuse requirement.....	20
Water ingress	10	In-line fuse and thermal breaker ratings.....	20
AIS disclaimer.....	10	CHAPTER 5 PRODUCT DIMENSIONS.....	22
Disclaimer	11	5.1 Product dimensions	23
Product disposal	11	CHAPTER 6 LOCATION REQUIREMENTS.....	24
Warranty registration.....	11	6.1 Selecting a location.....	25
Technical accuracy	11	General location requirements.....	25
Publication copyright.....	11	GNSS antenna location requirements.....	25
		EMC installation guidelines.....	25
		RF interference	26
		Compass safe distance	26
CHAPTER 2 DOCUMENT INFORMATION	12		
2.1 Applicable products	13		
2.2 Product documentation	13		
2.3 Document illustrations.....	13		

CHAPTER 7 CABLES AND CONNECTIONS — GENERAL INFORMATION	27	10.2 Power distribution	42
7.1 General cabling guidance	28	10.3 Grounding	44
Cable types and length	28	10.4 Power cable extension (12 / 24 V systems)	44
Routing cables	28	CHAPTER 11 SET UP AND CONFIGURATION	46
Strain relief	28	11.1 IMPORTANT — Configure before use	47
Circuit isolation	28	11.2 AIS licensing and MMSI	47
Cable shielding	28	11.3 Licensing and MMSI issuing authorities	47
Connecting cables	28	11.4 Configuration	50
7.2 Connections overview	29	Installing ProAIS2 software and USB	
7.3 VHF antenna requirements	29	drivers	51
CHAPTER 8 MOUNTING	31	Configuring using proAIS2	51
8.1 Mounting the unit	32	11.5 Viewing AIS data on a display	52
8.2 Mounting the GNSS (GPS) antenna	32	11.6 Software updates	53
CHAPTER 9 NETWORK CONNECTIONS	33	CHAPTER 12 MAINTENANCE	54
9.1 Data connections overview	34	12.1 Routine equipment checks	55
9.2 USB connection	36	12.2 Product cleaning	55
9.3 NMEA 2000 / SeaTalkng [®] connection	36	CHAPTER 13 TROUBLESHOOTING	56
9.4 NMEA 0183 connection	37	13.1 Power up troubleshooting	57
9.5 GPS (GNSS) antenna connection	38	13.2 AIS data troubleshooting	57
9.6 VHF antenna connection	39	VHF antenna requirements	58
VHF antenna requirements	39	13.3 VSWR Alarm troubleshooting	59
9.7 VHF radio connection	40	13.4 Data conflicts and data loops	59
9.8 Silent mode switch connection	40	13.5 LED Status indicator	59
CHAPTER 10 POWER CONNECTIONS	41	13.6 USB connection troubleshooting	59
10.1 Power connection	42	CHAPTER 14 TECHNICAL SUPPORT	60
In-line fuse and thermal breaker ratings	42	14.1 Product returns process	61
		14.2 Raymarine product support and servicing	62

14.3 Learning resources	63
CHAPTER 15 TECHNICAL SPECIFICATION	64
15.1 Power specification.....	65
15.2 Environmental specification	65
15.3 AIS specification.....	65
15.4 GNSS receiver specification.....	65
15.5 External connections.....	65
15.6 VHF antenna requirements	66
CHAPTER 16 SPARES AND ACCESSORIES	67
16.1 Spares and accessories.....	68
16.2 SeaTalkng [®] cables and accessories.....	68
APPENDIX A LICENSING AND MMSI ISSUING AUTHORITIES	73
APPENDIX B NMEA 0183 SUPPORTED SENTENCES	76
APPENDIX C NMEA 2000 SUPPORTED PGNS	76
APPENDIX D AIS LIMITATION	77
APPENDIX E CLASSES OF AIS.....	78
APPENDIX F DATA SUMMARY	78

CHAPTER 1: IMPORTANT INFORMATION

Safety warnings



Warning: Product installation and operation

- This product must be installed and operated in accordance with the instructions provided. Failure to do so could result in personal injury, damage to your vessel and/or poor product performance.
- Raymarine recommends certified installation by a Raymarine approved installer. A certified installation qualifies for enhanced product warranty benefits. Contact your Raymarine dealer for further details.



Warning: Grounding stud connection

Energy generated by Near-Lightning Strikes (NLS) and atmospheric static build-up can be conducted by the product, via the VHF antenna. To ensure that this energy is safely discharged, the grounding stud connection located on the product **MUST** be connected (via the supplied grounding strap) to the vessel battery's 0V negative terminal.

Failure to connect the grounding stud to the vessel battery's 0V negative terminal may cause permanent damage to the product and invalidate your product's warranty.



Warning: Potential ignition source

This product is **NOT** approved for use in hazardous/flammable atmospheres. Do **NOT** install in a hazardous/flammable atmosphere (such as in an engine room or near fuel tanks).

Product warnings



Warning: FCC Warning (Part 15.21)

Changes or modifications to this equipment not expressly approved in writing by Raymarine Incorporated could violate compliance with FCC rules and void the user's authority to operate the equipment.



Warning: IMPORTANT — Configure before use

Before first use this product **must** be correctly configured using a PC (Personal Computer) and the ProAIS2 software, which can be downloaded from the Raymarine website: www.raymarine.com/software

- Failure to configure the product will prevent correct operation.
- Configuration **MUST** include programming the product with an MMSI number. In some regions (such as the United States), the MMSI **must** be programmed by a qualified dealer or installer.
- Once the MMSI number has been entered using the ProAIS2 software and the configuration saved (via the "Write Configuration" option), the MMSI number cannot be subsequently changed, without returning the unit to an authorized Raymarine dealer for reprogramming. Always check the MMSI number before saving the configuration.
- Incorrect / incomplete configuration can cause erroneous data and prevent your product from transmitting.
- If an MMSI number is not programmed the product will operate as an AIS receiver only and will **NOT** transmit AIS information for your vessel.



Warning: VHF antenna

Ensure that your VHF antenna meets the requirements of the VHF antenna specification, which are detailed in the following section of this document: [p.29 – VHF antenna requirements](#)

- Using an antenna optimized for only AIS frequencies may damage the product.
- Using an antenna optimized for only VHF frequencies may cause erroneous alarms.
- Using an old antenna with degraded performance will result in reduced AIS performance.
- New VHF antennas are sold with a fixed cable length. The cable length partly determines the antenna performance, and therefore cutting the cable of an antenna can affect its performance and result in a high VSWR ratio and limited reception.



Warning: GNSS (GPS) antenna

- To enable the AIS to function, the supplied GNSS (GPS) passive antenna **MUST** be installed and connected.
- Ensure that the installation location has a clear line of sight to the sky.

Caution: Service and maintenance

This product contains no user serviceable components. Please refer all maintenance and repair to authorized Raymarine dealers. Unauthorized repair may affect your warranty.

Regulatory notices

RF safety notice

RF radiation statement

AIS **transceivers** generate and radiate radio frequency (RF) electromagnetic energy (EME).

[Important information](#)

Compliance Statement (Part 15.19)

This device complies with Part 15 of the FCC Rules. Operation is subject to the following two conditions:

1. This device may not cause harmful interference.
2. This device must accept any interference received, including interference that may cause undesired operation.

FCC Interference Statement (Part 15.105 (b))

This equipment has been tested and found to comply with the limits for a Class B digital device, pursuant to Part 15 of the FCC Rules.

These limits are designed to provide reasonable protection against harmful interference in a residential installation. This equipment generates, uses, and can radiate radio frequency energy and, if not installed and used in accordance with the instructions, may cause harmful interference to radio communications. However, there is no guarantee that interference will not occur in a particular installation. If this equipment does cause harmful interference to radio or television reception, which can be determined by turning the equipment off and on, the user is encouraged to try to correct the interference by one of the following measures:

1. Reorient or relocate the receiving antenna.
2. Increase the separation between the equipment and receiver.
3. Connect the equipment into an outlet on a circuit different from that to which the receiver is connected.
4. Consult the dealer or an experienced radio / TV technician for help.

Innovation, Science and Economic Development Canada (ISED)

This device complies with License-exempt RSS standard(s).

Operation is subject to the following two conditions:

1. This device may not cause interference; and
2. This device must accept any interference, including interference that may cause undesired operation of the device.

This Class B digital apparatus complies with Canadian ICES-003.

Innovation, Sciences et Développement économique Canada (Français)

Cet appareil est conforme aux normes d'exemption de licence RSS.

Son fonctionnement est soumis aux deux conditions suivantes:

1. cet appareil ne doit pas causer d'interférence, et
2. cet appareil doit accepter toute interférence, notamment les interférences qui peuvent affecter son fonctionnement.

Cet appareil numérique de la classe B est conforme à la norme NMB-003 du Canada.

AIS licensing and MMSI

Prior to using this product for the first time, please check your national requirements for both operator and equipment licensing.

Licensing

In many countries, the licensing for the use of AIS equipment is included in the **Ship Station license** and **Operator's license** issued for VHF radios.

However, even if you already have a Ship Station license and Operator's license for a VHF radio, **some countries may require a separate license for AIS equipment use.**

Important:

It is your responsibility to determine whether a license is required in your area before operating this equipment.

MMSI

An MMSI is a 9 digit number which is sent over a radio frequency channel in order to identify the originating vessel / station. **Before commencing installation ensure you have obtained an MMSI number for your vessel.**

This is a mandatory requirement. If your vessel already has an MMSI number (used for a VHF DSC radio, for example), then the same MMSI number must be used to program your AIS equipment.

Important:

In some areas, a radio operator licence is required before an MMSI number will be issued. If an MMSI number is not entered, your product can only be used in Silent Mode and will operate as a receiver only.

In the United States of America (USA), the MMSI and Static Data must be entered only by a Raymarine® dealer or other appropriately qualified installer of marine communications equipment for marine vessels.

In the USA, the user is NOT authorized to do this.

In Europe and other parts of the world outside of the United States of America, the MMSI and Static data can be set up by the user.

Important:

Once the MMSI number has been entered using the ProAIS2 software and the configuration saved (via the "Write Configuration" option), the MMSI number cannot be subsequently changed, without returning the unit to an authorized Raymarine dealer for reprogramming. Always check the MMSI number before saving the configuration.

For a list of issuing authorities for licences and MMSI numbers in each region, refer to: [p.47 — Licensing and MMSI issuing authorities](#)

Declaration of conformity

Raymarine UK Ltd declares that the radio equipment type AIS700 Class B transceiver, part number E70476, is in compliance with the Radio Equipment Directive 2014/53/EU.

The original Declaration of Conformity certificate may be viewed on the relevant product page at www.raymarine.com/manuals

Water ingress

Water ingress disclaimer

Although the waterproof rating capacity of this product meets the stated water ingress protection standard (refer to the product's *Technical Specification*), water intrusion and subsequent equipment failure may occur if the product is subjected to high-pressure washing. Raymarine will not warrant products subjected to high-pressure washing.

AIS disclaimer

All information presented by the AIS700 is advisory only, as there is a risk of incomplete and erroneous information. By placing this product into service you acknowledge this and assume complete responsibility for any associated risks, and accordingly release Raymarine and SRT Marine System plc from any and all claims arising from the use of the AIS service.

Disclaimer

Raymarine does not warrant that this product is error-free or that it is compatible with products manufactured by any person or entity other than Raymarine.

Raymarine is not responsible for damages or injuries caused by your use or inability to use the product, by the interaction of the product with products manufactured by others, or by errors in information utilized by the product supplied by third parties.

Third-party hardware, such as converters, adapters, routers, switches, Access Points etc., provided by third parties, may be made available directly to you by other companies or individuals under separate terms and conditions, including separate fees and charges. Raymarine UK Limited or its affiliates have not tested or screened the third-party hardware.

Raymarine has no control over, and is not responsible for:

- (a) the content and operation of such third-party hardware; or
- (b) the privacy or other practices of such third-party hardware.

The fact that Raymarine's documentation may make reference to such third-party hardware does not indicate any approval or endorsement of any such third-party hardware. Raymarine may reference such third-party hardware only as a convenience.

THIS INFORMATION IS MADE AVAILABLE BY RAYMARINE UK LIMITED ON THE BASIS THAT YOU EXCLUDE TO THE FULLEST EXTENT LAWFULLY PERMITTED ALL LIABILITY WHATSOEVER FOR ANY LOSS OR DAMAGE HOWSOEVER ARISING OUT OF THE USE OF THIS INFORMATION OR RELIANCE UPON THIS INFORMATION.

Raymarine UK Limited does not exclude **Raymarine UK Limited's** liability (if any) to you for personal injury or death resulting from **Raymarine UK Limited's** negligence, for fraud or for any matter which it would be illegal to exclude or to attempt to exclude.

Product disposal

Dispose of this product in accordance with the WEEE Directive.

The Waste Electrical and Electronic Equipment (WEEE) Directive requires the recycling of waste electrical and electronic equipment which contains materials, components and substances that may be hazardous and present a risk to human health and the environment when WEEE is not handled correctly.

[Important information](#)

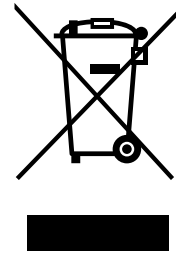

Equipment marked with the crossed-out wheeled bin symbol indicates that the equipment should not be disposed of in unsorted household waste. Local authorities in many regions have established collection schemes under which residents can dispose of waste electrical and electronic equipment at a recycling center or other collection point. For more information about suitable collection points for waste electrical and electronic equipment in your region, refer to the Raymarine website: www.raymarine.com/en-gb/policies/recycling

Warranty registration

To register your Raymarine product ownership, please visit www.raymarine.com and register online.

It is important that you register your product to receive full warranty benefits. Your unit package includes a bar code label indicating the serial number of the unit. You will need this serial number when registering your product online. You should retain the label for future reference.

Technical accuracy

To the best of our knowledge, the information in this document was correct at the time it was produced. However, Raymarine cannot accept liability for any inaccuracies or omissions it may contain. In addition, our policy of continuous product improvement may change specifications without notice. As a result, Raymarine cannot accept liability for any differences between the product and this document. Please check the Raymarine website (www.raymarine.com) to ensure you have the most up-to-date version(s) of the documentation for your product.

Publication copyright

Copyright ©2023 Raymarine UK Ltd. All rights reserved. No parts of this material may be copied, translated, or transmitted (in any medium) without the prior written permission of Raymarine UK Ltd.

CHAPTER 2: DOCUMENT INFORMATION

CHAPTER CONTENTS

- 2.1 Applicable products — page 13
- 2.2 Product documentation — page 13
- 2.3 Document illustrations — page 13

2.1 Applicable products

This document is applicable to the following products:

Description	Part number
The AIS700 is a Class B AIS transceiver with a built-in VHF splitter, used to display real-time information on local vessels, land based stations or aids to navigation that are equipped with either Class A or Class B AIS transceivers. For more information on AIS, refer to the Appendix.	E70476

2.2 Product documentation

The following documentation is applicable to your product:

Description	Part number
AIS700 Installation instructions (this document)	87326
Installation of an AIS700 and connection to a wider system of marine electronics.	
GNSS antenna Mounting template	87225
LightHouse™ 4 Operation instructions	81406
Operation instructions for LightHouse™ 4 MFDs, including AIS-related functions.	
LightHouse™ 3 Operation instructions	81370
Operation instructions for LightHouse™ 3 MFDs, including AIS-related functions.	
LightHouse™ 2 Operation instructions	81360
Operation instructions for LightHouse™ 2 MFDs, including AIS-related functions.	

2.3 Document illustrations

Your product and if applicable, its user interface may differ slightly from that shown in the illustrations in this document, depending on product variant and date of manufacture.

All images are provided for illustration purposes only.

CHAPTER 3: PRODUCT AND SYSTEM OVERVIEW

CHAPTER CONTENTS

- [3.1 AIS overview — page 15](#)
- [3.2 Compatible Raymarine® displays — page 16](#)

3.1 AIS overview

AIS (Automatic Identification System) transceivers use digital radio signals to exchange 'real-time' information between vessels, shore based stations, or aids to navigation (AToNs) on dedicated VHF frequencies. This information is used to identify and track vessels in the surrounding area and to provide fast, automatic and accurate collision avoidance data. AIS technology achieves this by continuously transmitting a vessel's identity, position, speed and course, along with other relevant information to all other AIS-equipped vessels within range.

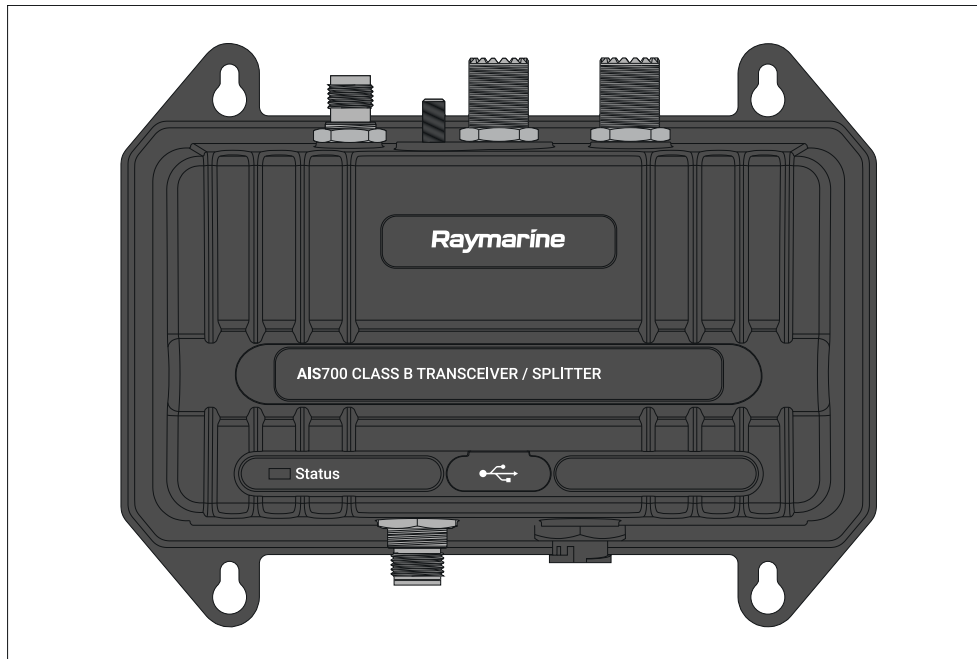

Although AIS technology augments your Radar app by operating in Radar blind spots and detecting smaller AIS-fitted vessels, it does not replace your Radar, as it relies on receiving transmitted AIS information, and therefore cannot detect objects such as landmasses, navigational beacons or vessels not equipped with AIS.

Note:

NEVER assume that AIS is displaying information from all vessels in the area, because:

- Not all vessels are fitted with AIS.
- Although it is mandatory for larger commercial vessels to carry AIS equipment, it is not mandatory to use it.
- Most Class B AIS transponders only have a transmission power output of 2 W, which restricts Class B transmissions to a maximum range of 8-10 nautical miles, and means that transmissions from vessels using traditional Class B AIS transponders are often not received by the AIS satellites that provide global vessel tracking. (Please note, however, the AIS700 uses SOTDMA technology with a 5 W power output, providing an increased transmission range of approximately 10-12 nautical miles.)

AIS should be used only to *augment* Radar information, **not to substitute it**.

CSTDMA vs SOTDMA

The AIS700 uses SOTDMA (Self-Organized Time-Division Multiple Access) communication technology, which has significant advantages over the traditional CSTDMA (Carrier-Sense Time-Division Multiple Access) technology used in many Class B AIS transponders:

- With its 5 W transmission power output, SOTDMA provides an increased transmission range of approximately 10-12 nautical miles.
- SOTDMA provides *Guaranteed Time Slot Allocation* in its AIS messaging scheme, which means that the transmissions from this device will take priority over standard Class B transponders, when multiple transponders are attempting to reserve the same transmission time slot.
- SOTDMA provides an increased update speed of up to every 5 seconds, compared to every 30 seconds for a Class B transponder using CSTDMA technology. This means that, as your vessel's speed increases, the number of AIS transmissions increases compared to a vessel using the older CSTDMA technology, giving other vessels a clearer and more up-to-date view of where your vessel is. This is particularly useful for fast-moving planing vessels. For example, a vessel travelling at 23 knots will move 360 metres in the 30 seconds it takes one of the older Class B CSTDMA transponders to transmit its next AIS signal (or 0.5 nautical miles at 30 knots). By comparison, on a boat equipped with a Class B SOTDMA transponder travelling at 23 knots or more, the update rate is just 5

seconds, meaning that your AIS position would be transmitted every 60 meters travelled.

3.2 Compatible Raymarine® displays

The AIS receiver/transceiver is compatible with the MFDs shown below. displays can be connected using either a SeaTalkng® backbone or NMEA 0183 connection set to 38,400 baud rate. Where available it is recommended that the SeaTalkng® / NMEA 2000 connection is used.

Axiom 2 multifunction displays

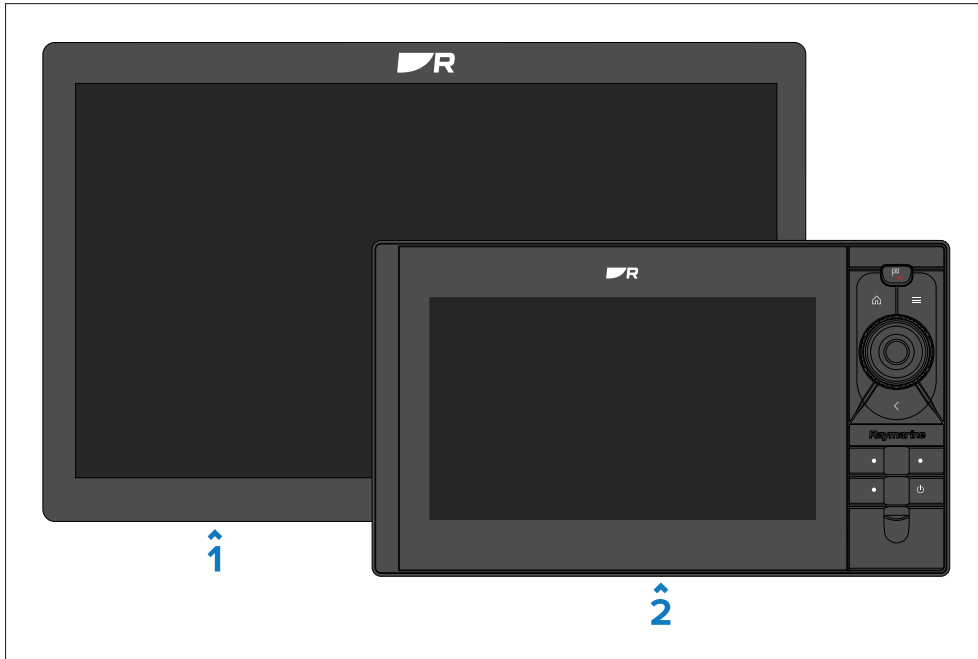

1. Axiom 2 XL
2. Axiom 2 Pro

Axiom multifunction displays

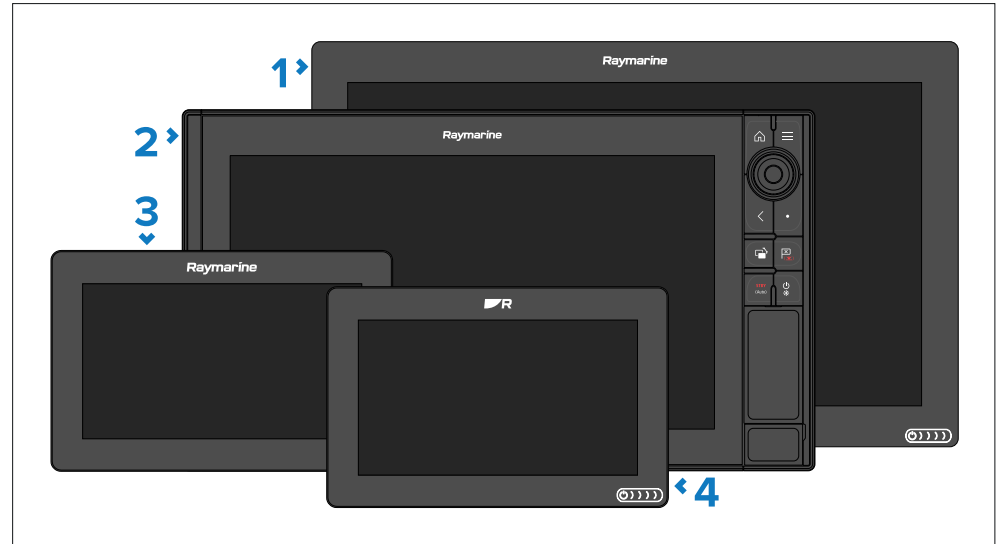

1. Axiom XL
2. Axiom Pro / Pro-S
3. Axiom
4. Axiom +

gS / eS / aSeries / eSeries / cSeries multifunction displays

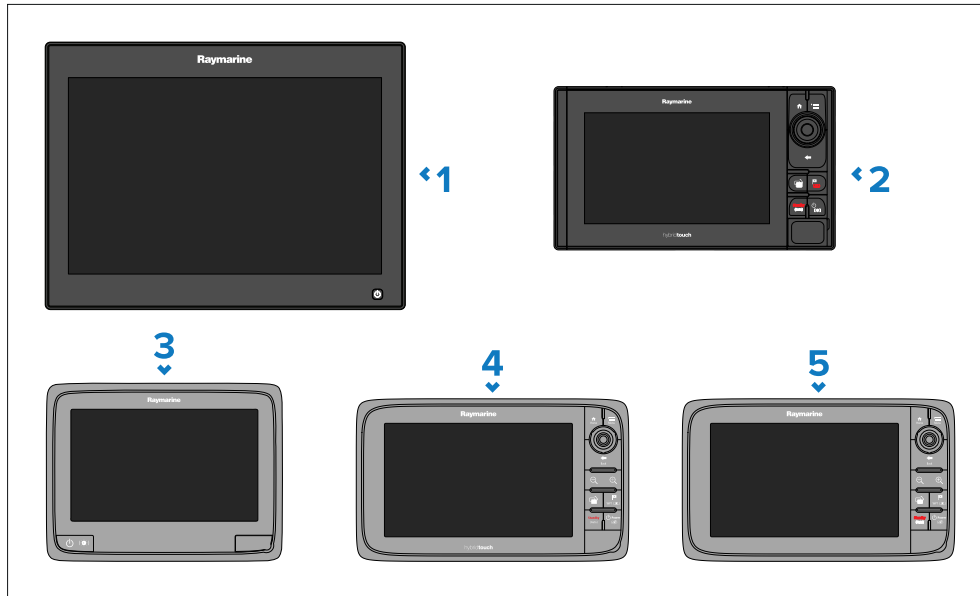

1. gS Series
2. eS Series
3. aSeries
4. eSeries
5. cSeries

i70 / i70s instrument displays

Compatible instrument displays can be connected to the same SeaTalkng[®] network.



1. i70
2. i70s

Legacy multifunction displays

Note:

E Series Classic and C Series Classic MFDs can only be connected using a NMEA 0183 connection.

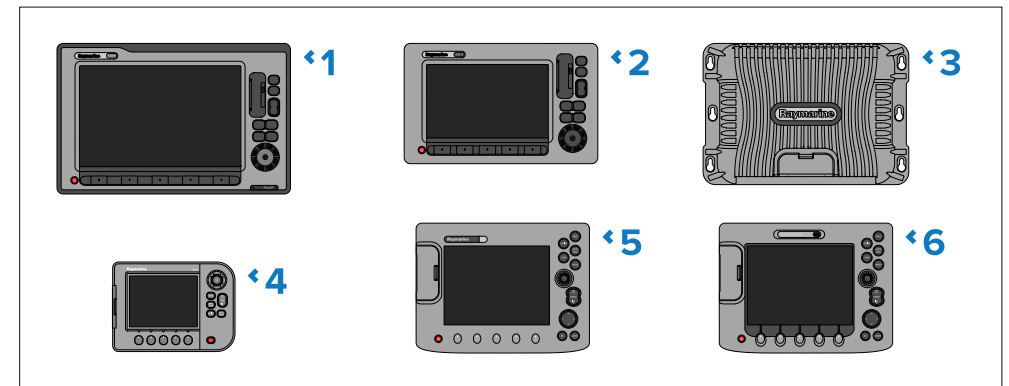

1. E-Series Widescreen MFDs
2. C-Series Widescreen MFDs
3. G-Series systems
4. A-Series MFDs

5. C Series Classic MFDs (Connection via NMEA 0183 only)
6. E Series Classic MFDs (Connection via NMEA 0183 only)

Compatible third-party displays

The AIS receiver/transceiver can be connected to displays manufactured by third-parties.

Third-party displays can be connected using either a NMEA 2000 or a NMEA 0183 connection set to 38,400 baud rate. Where available it is recommended that a NMEA 2000 connection is used where possible.

Note:

The data available to third-party displays will be limited to the NMEA 2000 PGNs and NMEA 0183 sentences that are supported by both the AIS receiver/transceiver and the third-party display.

CHAPTER 4: PARTS SUPPLIED

CHAPTER CONTENTS

- 4.1 Parts supplied — page 20
- 4.2 Inline fuse requirement — page 20

4.1 Parts supplied

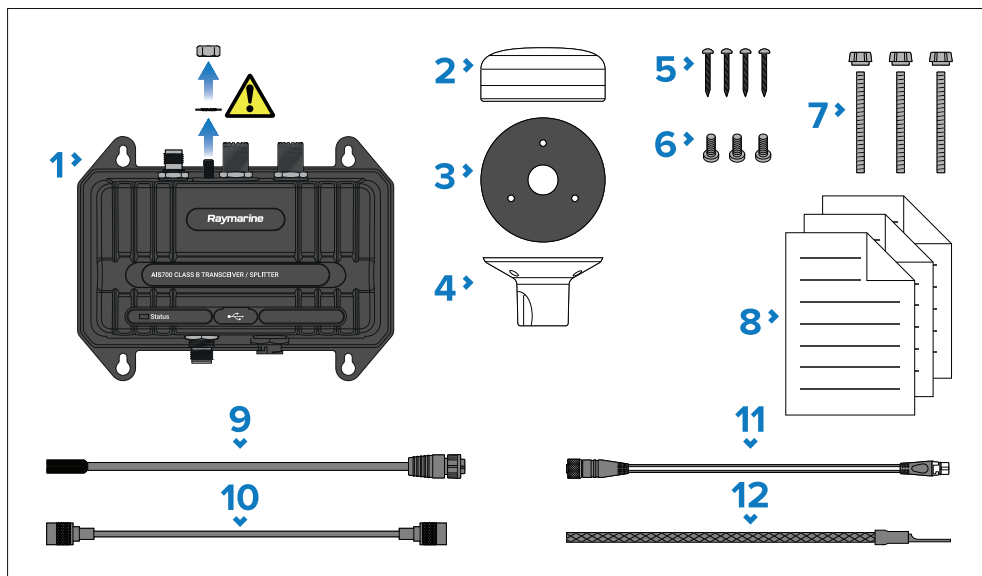

1. AIS700 unit. For an explanation of the warning symbol shown, refer to the Important Note below.
2. GNSS antenna, with captive cable, 10 m (33 ft).
3. GNSS antenna gasket.
4. GNSS antenna pole mount.
5. AIS unit fixings (4x No.8x19 self-tapping screws).
6. Screws for (optional) pole-mounting of the GNSS antenna.
7. Fixings for (optional) surface mounting of the GNSS antenna (3x M3x40 stud and thumb nut).
8. Product documentation.
9. Power/data cable, 2 m (6.56 ft).
10. VHF Radio cable, 1 m (3.28 ft).
11. DeviceNet to SeaTalkng adaptor cable, 1 m (3.28 ft).
12. Grounding strap.

Important:

The AIS unit is supplied with a nut and washer pre-fitted to the unit's grounding lug. This dedicated grounding point **must** be connected via the supplied grounding strap to your vessel battery's 0V negative battery terminal. For more information, refer to the label attached to the unit's grounding lug, as well as the following section: [p.44 — Grounding](#)

4.2 Inline fuse requirement

Your product requires a suitably-rated inline fuse to be fitted to the red power wire, housed in a waterproof fuse holder.

This fuse and its fuse holder are **NOT supplied** with your product, and must be obtained separately, from a marine or electrical retailer.

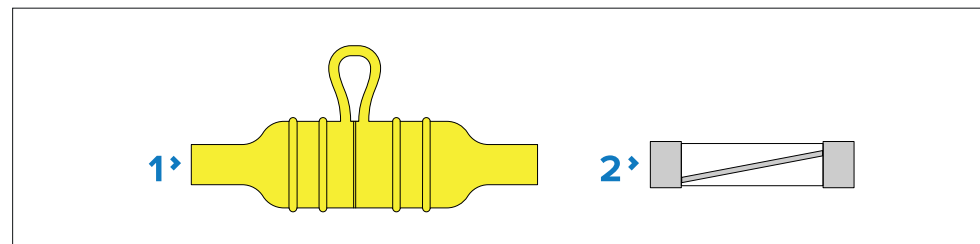

1. Waterproof fuse holder.
2. Suitably-rated inline fuse.

Fuse ratings:

- Voltage rating — must be equal to or greater than the voltage of your vessel's power supply.
- Current rating — refer to the *Inline fuse and thermal breaker rating* section listed below.

In-line fuse and thermal breaker ratings

The following in-line fuse and thermal breaker ratings apply to your product:

Inline fuse rating	Thermal breaker rating
3 A	3 A

Note:

- The suitable fuse rating for the thermal breaker is dependent on the number of devices you are connecting. If in doubt consult an authorized Raymarine dealer.
- Your product's power cable may have an in-line fuse fitted, if not then you must add an in-line fuse / breaker to the positive wire of your product's power connection.

CHAPTER 5: PRODUCT DIMENSIONS

CHAPTER CONTENTS

- [5.1 Product dimensions — page 23](#)

5.1 Product dimensions

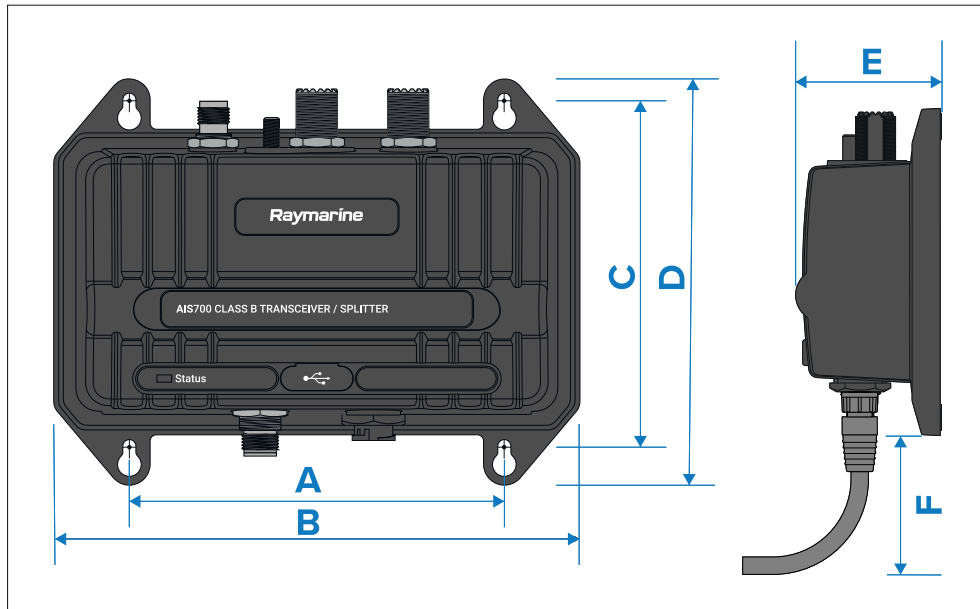

Item	Dimension
A	122.29 mm (4.81 in)
B	171.65 mm (6.76 in)
C	113.04 mm (4.45 in)
D	132.55 mm (5.22 in)
E	57 mm (2.24 in)
F	100 mm (3.94 in)

CHAPTER 6: LOCATION REQUIREMENTS

CHAPTER CONTENTS

- [6.1 Selecting a location — page 25](#)

6.1 Selecting a location



Warning: Potential ignition source

This product is NOT approved for use in hazardous/flammable atmospheres. Do NOT install in a hazardous/flammable atmosphere (such as in an engine room or near fuel tanks).

General location requirements

When selecting a location for your product, it is important to consider a number of factors.

- **Water ingress** — The unit should be mounted below decks. Although the unit is waterproof, it is good practice to locate it in a protected area away from prolonged and direct exposure to rain and salt spray.
- **Ventilation** — To ensure adequate airflow:
 - Ensure that the unit is mounted in a compartment of suitable size.
 - Ensure that ventilation holes are not obstructed. Allow adequate separation of all equipment.
- **Electrical interference** — Select a location that is far enough away from devices that may cause interference, such as motors, generators and radio transmitters / receivers.
- **Power supply** — Select a location that is as close as possible to the vessel's DC power source. This will help to keep cable runs to a minimum.
- **Diagnostics** — The unit must be mounted in a location where any diagnostics LEDs are easily visible.
- **Mounting surface** — Ensure the unit is adequately supported on a secure surface. Do not mount units or cut holes in places which may damage the structure of the vessel.
- **Cabling** — Ensure the unit is mounted in a location which allows proper routing, support and connection of cables:
 - Minimum bend radius of 100 mm (3.94 in) unless otherwise stated.
 - Use cable clips to prevent stress on connectors.
 - If your installation requires multiple ferrites to be added to a cable then additional cable clips should be used to ensure the extra weight of the cable is supported.

GNSS antenna location requirements

The supplied GNSS antenna must be installed in accordance with the instructions provided. Do NOT connect any other GNSS antenna other than that supplied.

The GNSS antenna can be mounted either on a flat horizontal surface or on a suitable pole.

- If you intend to surface mount the antenna, ensure you have access to the underside of the mounting surface.
- If you intend to pole-mount the antenna, the pole needs to have a 1 inch 14 TPI thread.

Important:

The GNSS antenna must be mounted in a location that provides a good direct line-of-sight to the entire sky, around the horizon.

Ensure that the selected mounting location is:

- Open and clear of any obstructions (such as masts, search lights, or other structures) that could block line-of-sight to the sky.
- As low as possible, to keep the antenna as stable as possible. The more stable the antenna, the more effectively it will track satellites and provide stable data.
- As far as possible (at least 1 m (3 ft)) from other antennae and electronic equipment.

Do NOT mount the antenna:

- In any area where it could be stepped on or tripped over.
- Up a mast. This will cause the antenna to swing and give significant errors in position data.
- In the direct path of a Radar beam.

EMC installation guidelines

Raymarine® equipment and accessories conform to the appropriate Electromagnetic Compatibility (EMC) regulations, to minimize electromagnetic interference between equipment and minimize the effect such interference could have on the performance of your system

Correct installation is required to ensure that EMC performance is not compromised.

Note:

In areas of extreme EMC interference, some slight interference may be noticed. Where this occurs the product and the source of the interference should be separated by a greater distance.

For **optimum** EMC performance we recommend that wherever possible:

- Raymarine® equipment and cables connected to it are:
 - At least 1 m (3 ft) from any equipment transmitting or cables carrying radio signals e.g. VHF radios, cables and antennas. In the case of SSB radios, the distance should be increased to 2 m (7 ft).
 - More than 2 m (7 ft) from the path of a Radar beam. A Radar beam can normally be assumed to spread 20 degrees above and below the radiating element.
- The product is supplied power from a separate battery from that used for engine start. This is important to prevent erratic behavior and data loss which can occur if the engine start does not have a separate battery.
- Only Raymarine® specified cables are used.
- Cables are not cut or extended, unless doing so is detailed in the installation instructions.

Note:

Where constraints on the installation prevent any of the above recommendations, always ensure the maximum possible separation between different items of electrical equipment, to provide the best conditions for EMC performance throughout the installation.

Suppression ferrites

- Raymarine cables may be pre-fitted or supplied with suppression ferrites. These are important for correct EMC performance. If ferrites are supplied separately to the cables (i.e. not pre-fitted), you must fit the supplied ferrites, using the supplied instructions.
- If a ferrite has to be removed for any purpose (e.g. installation or maintenance), it must be replaced in the original position before the product is used.
- Use only ferrites of the correct type, supplied by Raymarine or its authorized dealers.

- Where an installation requires multiple ferrites to be added to a cable, additional cable clips should be used to prevent stress on the connectors due to the extra weight of the ferrites.

Connections to other equipment

Requirement for ferrites on non-Raymarine cables.

If your product is to be connected to other equipment using a cable not supplied by Raymarine, a suppression ferrite **MUST** always be attached to the end of the cable nearest to the Raymarine product.

RF interference

Certain third-party external electrical equipment can cause Radio Frequency (RF) interference with GNSS (GPS), AIS or VHF devices, if the external equipment is not adequately insulated and emits excessive levels of electromagnetic interference (EMI).

Some common examples of such external equipment include LED lighting (e.g.: navigation lights, searchlights and floodlights, interior and exterior lights) and terrestrial TV tuners.

To minimize interference from such equipment:

- Keep it as far away from GNSS (GPS), AIS or VHF products and their antennas as possible.
- Ensure that any power cables for external equipment are not entangled with the power or data cables for these devices.
- Consider fitting one or more high frequency suppression ferrites to the EMI-emitting device. The ferrite(s) should be rated to be effective in the range 100 MHz to 2.5 GHz, and should be fitted to the power cable and any other cables exiting the EMI-emitting device, as close as possible to the position where the cable exits the device.

Compass safe distance

When choosing a suitable location for your product you should aim to maintain the maximum possible distance between the product and any installed compass. This distance should be at least 1 m (3.3 ft) in all directions. For smaller vessels it may not be possible to achieve this distance. In this situation ensure that the compass is not affected by the product when it is powered on.

CHAPTER 7: CABLES AND CONNECTIONS — GENERAL INFORMATION

CHAPTER CONTENTS

- 7.1 General cabling guidance — page 28
- 7.2 Connections overview — page 29
- 7.3 VHF antenna requirements — page 29

7.1 General cabling guidance

Cable types and length

It is important to use cables of the appropriate type and length.

- Unless otherwise stated only use cables supplied by Raymarine.
- Where it is necessary to use non-Raymarine cables, ensure that they are of correct quality and gauge for their intended purpose. (e.g.: longer power cable runs may require larger wire gauges to minimize voltage drop along the run).

Routing cables

Cables must be routed correctly, to maximize performance and prolong cable life.

- Do NOT bend cables excessively. Wherever possible, ensure a minimum bend diameter of 200 mm (8 in) / minimum bend radius of 100 mm (4 in).

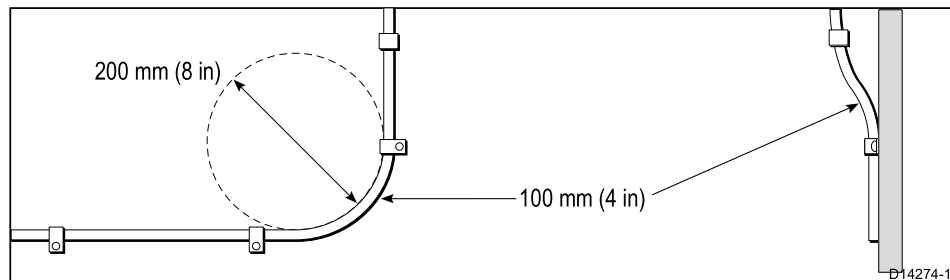

- Protect all cables from physical damage and exposure to heat. Use trunking or conduit where possible. Do NOT run cables through bilges or doorways, or close to moving or hot objects.
- Secure cables in place using tie-wraps or lacing twine. Coil any extra cable and tie it out of the way.
- Where a cable passes through an exposed bulkhead or deckhead, use a suitable watertight feed-through.
- Do NOT run cables near to engines or fluorescent lights.

Always route data cables as far away as possible from:

- other equipment and cables,
- high current carrying ac and dc power lines,

- antennae.

Strain relief

Use adequate strain relief for cabling to ensure that connectors are protected from strain and will not pull out under extreme sea conditions.

Circuit isolation

Appropriate circuit isolation is required for installations using both AC and DC current:

- Always use isolating transformers or a separate power-inverter to run PCs, processors, displays and other sensitive electronic instruments or devices.
- If using Weather FAX audio cables, always use an isolating transformer.
- If using a third-party audio amplifier, always use an isolated power supply.
- If using an RS232/NMEA converter, always ensure optical isolation on the signal lines.
- Always ensure that PCs or other sensitive electronic devices have a dedicated power circuit.

Cable shielding

Ensure that cable shielding is not damaged during installation and that all cables are properly shielded.

Connecting cables

Follow the steps below to connect the cable(s) to your product.

1. Ensure that the vessel's power supply is switched off.
2. Ensure that the device being connected has been installed in accordance with the installation instructions supplied with that device.
3. Ensuring correct orientation, push cable connectors fully onto the corresponding connectors.
4. Engage any locking mechanism to ensure a secure connection (e.g.: turn locking collars clockwise until tight, or in the locked position).
5. Ensure any bare ended wire connections are suitably insulated to prevent shorting and corrosion due to water ingress.

7.2 Connections overview

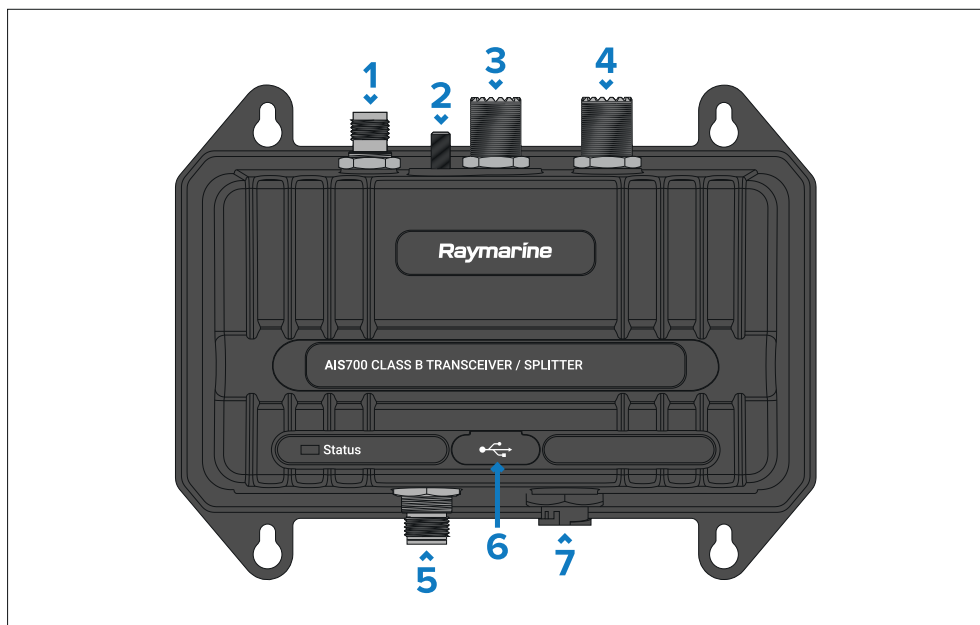

Connections

Suitable cables

1) GNSS connection

GNSS antenna's fitted cable.

Connects to the supplied GNSS antenna. This antenna must be connected to the AIS unit.

2) Grounding earth stud connection

Grounding strap (supplied).

Connects to vessel battery's 0 V negative battery terminal.

For further information, refer to: [p.44 – Grounding](#)

Important:

You **must** make this connection for safety reasons; it is not optional. Its purpose is to reduce potential damage caused by near lightning strikes and static build-up in the atmosphere.

Connections

Suitable cables

3) Antenna connection

VHF antenna cable.

Connects to VHF antenna.

4) VHF connection

VHF radio cable (supplied).

Connects to VHF Radio.

5) NMEA 2000 / SeaTalkng connection

Either:

Connects to NMEA 2000 or SeaTalkng backbone.

- A DeviceNet to SeaTalkng adaptor cable (supplied), or;
- A DeviceNet spur cable.

6) USB connection

Micro-B USB cable.

Connects to PC (Personal Computer).

Note:

If you encounter issues connecting the AIS unit to a PC/laptop via USB, try changing the USB cable in the first instance. If that does not resolve your issue, try using a different USB port, and also avoid using ports on USB hubs.

7) Power and data connection

Power/data cable (supplied).

Connects to:

- 12/24 V dc power supply.
- NMEA 0183 devices.
- Silent mode switch.

7.3 VHF antenna requirements

Important requirements related to the type and specification of the VHF antenna required for your AIS unit.

To ensure optimum antenna performance, adhere to the following guidelines:

- The use of a **wideband** VHF antenna is highly recommended, rather than an AIS-only antenna.
- The AIS700 requires a wideband antenna to provide good performance for both the AIS transceiver and a connected VHF radio utilizing the AIS700's integrated antenna splitter.
- Using a VHF antenna optimized for only AIS frequency operation may permanently damage the AIS700, as VHF radio transmissions are reflected back into the AIS700 due to the poor impedance match of the VHF antenna operating at VHF radio frequencies.
- Using a **non**-wideband VHF antenna optimized only for VHF radio frequencies may cause transmissions from the AIS transceiver to be reflected back into the AIS700, due to the poor impedance match of the antenna and AIS transceiver frequencies. Although this will not damage the AIS700 (because AIS class B transmissions are of substantially lower power than VHF transmissions), it could result in the AIS700 triggering a system VSWR alarm.
- New VHF antennas are sold with a fixed cable length. The cable length partly determines the antenna performance, and therefore cutting the cable of an antenna can affect its performance and result in a high VSWR ratio and limited reception.

Recommended VHF antenna specifications

Specifications	
Frequency band:	156.025 MHz to 162.025 MHz
VSWR (Voltage Standing Wave Ratio):	Should not exceed 2:1, across the entire frequency range
Impedance:	50 Ohm wideband
Gain:	3dBi Max
Connector type:	PL-259

CHAPTER 8: MOUNTING

CHAPTER CONTENTS

- [8.1 Mounting the unit — page 32](#)
- [8.2 Mounting the GNSS \(GPS\) antenna — page 32](#)

8.1 Mounting the unit

Before mounting the unit, ensure that you have:

- Selected a suitable location (a clear, flat surface is required).
- Identified the relevant cable connections and the route that the cable will take.

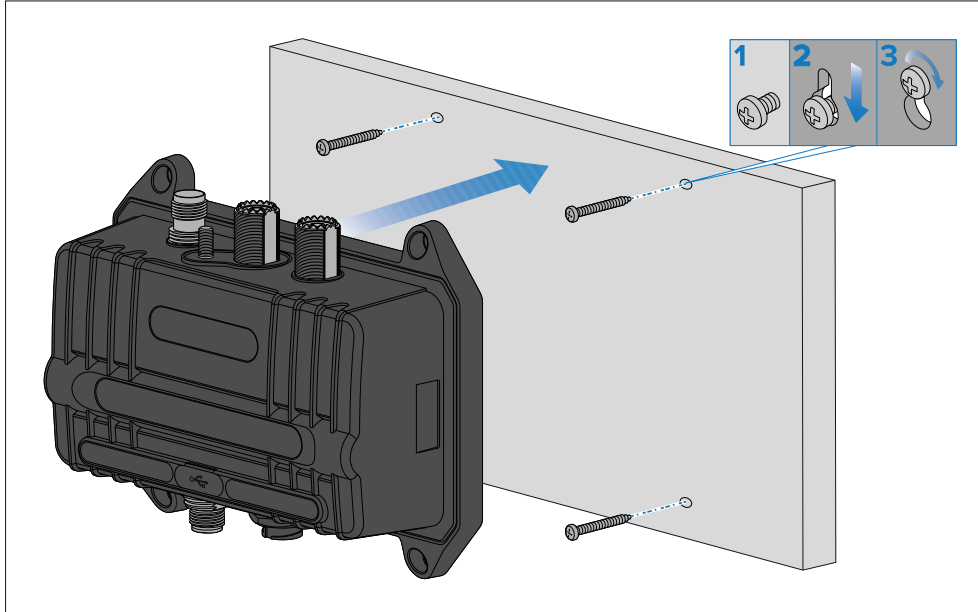

1. Using the unit as a guide, mark the location of the mounting holes on the mounting surface.
2. Drill holes for the mounting fixings using a drill with a suitable sized drill bit.
3. Screw the fixings approximately half way into the holes in the mounting surface.
4. Place the unit over the fixing screws and push down to lock into position.
5. Fully tighten the screws.
6. Connect the necessary cables.

8.2 Mounting the GNSS (GPS) antenna

To mount the antenna:

1. Select a suitable location for the antenna, as described in the following section: [p.25 – GNSS antenna location requirements](#)
2. **Mount your antenna according to the instructions provided in the following document: 88092 GA200 Installation instructions.** The document is supplied with the GNSS antenna, and is also available to download from the Raymarine® website: www.raymarine.com/manuals

Important:

If you are replacing a GPS antenna supplied with an older AIS receiver or an AIS700 with an early (low) serial number, please be aware that the mounting diameter (cutout) of the GPS receiver has changed, from Ø44 mm to Ø60 mm.

CHAPTER 9: NETWORK CONNECTIONS

CHAPTER CONTENTS

- 9.1 Data connections overview — page 34
- 9.2 USB connection — page 36
- 9.3 NMEA 2000 / SeaTalkng® connection — page 36
- 9.4 NMEA 0183 connection — page 37
- 9.5 GPS (GNSS) antenna connection — page 38
- 9.6 VHF antenna connection — page 39
- 9.7 VHF radio connection — page 40
- 9.8 Silent mode switch connection — page 40

9.1 Data connections overview

The AIS unit includes 2 bidirectional NMEA 0183 connections, as well as NMEA 2000 / SeaTalkng, and USB connections. The AIS unit can multiplex the data received on its NMEA 0183 inputs with its AIS data, and then output this combined data to an external NMEA 0183 device, via the AIS unit's high speed (38,400) NMEA 0183 output.

It is important to choose the right **combination** of input and output connections on your AIS unit, in order to exchange the types of data that you require.

The following table shows the types of data that can be exchanged via the AIS unit, for each **combination** of input **and** output. As an example of how to use the table below, examine the **input** listed as *NMEA 0183 (4,800) GNSS* in the "Inputs" column, in the first row of the table. Reading across that same row, you can see that the GNSS GPS data received on that input cannot be exchanged with the NMEA 0183 (4,800) **output**, but it **can** be exchanged with the *NMEA 0183 (38,400)* output.

Important:

The AIS unit has its own GNSS (GPS) receiver. This GPS data can be multiplexed with the AIS data and output on the high speed (38,400) NMEA 0183 output. However, this feature is intended **for diagnostic and troubleshooting purposes only**. To prevent potential GPS data conflicts or loops and / or performance issues, **the AIS unit's internal GPS receiver is intended to provide GPS data to the AIS unit only**. Therefore, the AIS unit's GNSS (GPS) receiver should NOT be used to provide GNSS (GPS) data to multifunction displays or any other external device.

Raymarine recommends that an additional external NMEA 0183 or SeaTalk^{ng} GNSS (GPS) receiver is used to provide GNSS (GPS) data to your external devices, as shown in the following table:

INPUTS	OUTPUTS							
	NMEA 0183				NMEA 2000 / SeaTalkng		USB	
	4,800 (LO) Baud Rate		38,400 (HI) Baud Rate					
(GNSS GPS data sourced from an external GNSS GPS device) (not the AIS unit's internal GPS receiver)	GNSS (GPS)	AIS	GNSS (GPS)	AIS	GNSS (GPS)	AIS	GNSS (GPS)	AIS
NMEA 0183 (4,800 Baud) GNSS (GPS)	✗	✗	✓	✓	✗	✓	✗	✗
NMEA 0183 (38,400 Baud) GNSS (GPS)	✓	✗	✗	✗	✗	✓	✗	✗
NMEA 2000 / SeaTalkng GNSS (GPS)	✗	✗	✗	✓	✗	✓	✗	✓

Important:

To avoid potential data conflicts or loops, avoid connecting the AIS unit to multiple (and different) data buses on an external unit **at the same time**:

- Do NOT connect the AIS unit to an MFD via NMEA 0183 **and** SeaTalkng / NMEA 2000 connections **at the same time**.
- Do NOT connect the AIS unit to a VHF Radio via NMEA 0183 **and** SeaTalkng / NMEA 2000 connections **at the same time**.
- Do NOT connect the AIS unit to a PC via NMEA 0183 **and** USB connections **at the same time**.

Important:

If you are connecting to an AIS-capable VHF Radio, you must first disable the VHF Radio's AIS function. Refer to your Radio's documentation for details on disabling its AIS function.

Note:

- It is possible to configure the baud rate for each NMEA 0183 port in the ProAIS software. However, this feature is intended **for diagnostic and troubleshooting purposes only**. The ProAIS2 software can be downloaded from the Raymarine website: www.raymarine.com/software
- For more information on NMEA 0183 connections, refer to: [p.37 – NMEA 0183 connection](#)
- For a list of supported NMEA 0183 sentences, refer to: [p.76 – NMEA 0183 supported sentences](#)
- For more information on NMEA 2000 / SeaTalkng connections, refer to: [p.36 – NMEA 2000 / SeaTalkng connection](#)
- For a list of supported NMEA 2000 PGNs, refer to: [p.76 – NMEA 2000 supported PGNs](#)
- For more information on the USB connection, refer to: [p.36 – USB connection](#)
- For more information on the GNSS antenna connection, refer to: [p.38 – GPS \(GNSS\) antenna connection](#)

9.2 USB connection

Before using your product for the first time, you must configure it using the proAIS2 software, via a PC connected to the USB connection.

Note:

The ProAIS2 software can be downloaded from the Raymarine website:
www.raymarine.com/software

Important:

Configuration of the unit includes programming it with an MMSI number. In the United States of America, it is a violation of the rules of the Federal Communications Commission to input an MMSI that has not been properly assigned to the end user or to otherwise input any inaccurate data in this device. The MMSI and Static Data must be entered only by a Raymarine dealer or other appropriately qualified installer of marine communications equipment on board vessels.

Ensure you check the regulations for your location to ensure you are allowed to configure MMSI data on your unit.

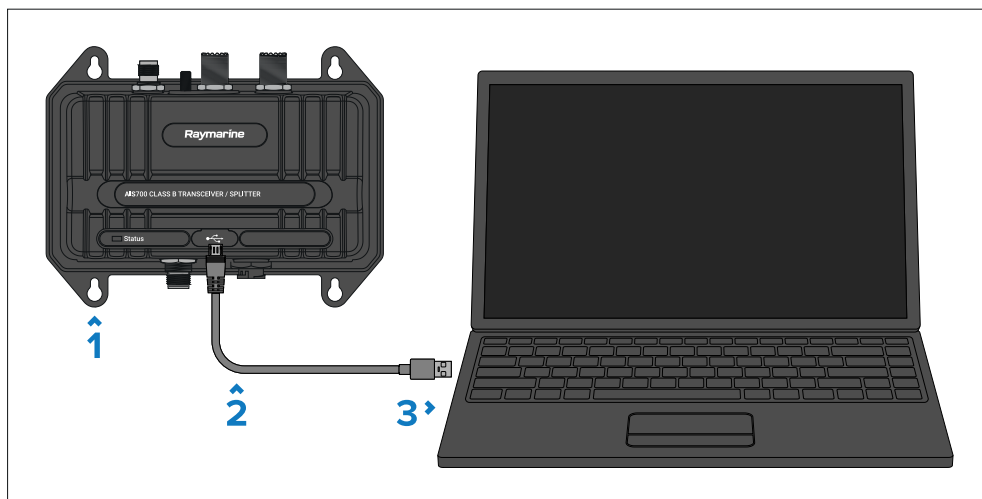

1. AIS unit
2. USB Micro-B to type A cable (not supplied)
3. PC (personal computer) running proAIS2

Note:

- The PC USB connection will provide power to the unit to enable configuration prior to installation.
- For details on configuring your unit, refer to:
[p.46 — Set up and configuration](#)

Note:

If you encounter issues connecting the AIS unit to a PC/laptop via USB, try changing the USB cable in the first instance. If that does not resolve your issue, try using a different USB port, and also avoid using ports on USB hubs.



Warning: USB device power

Do NOT connect any device to the product's USB connection that requires an external power source.

9.3 NMEA 2000 / SeaTalkng[®] connection

Your product can transmit data to devices connected on SeaTalkng[®] or NMEA 2000 CAN bus networks. Connection is established using the DeviceNet connector located on the bottom of the unit.

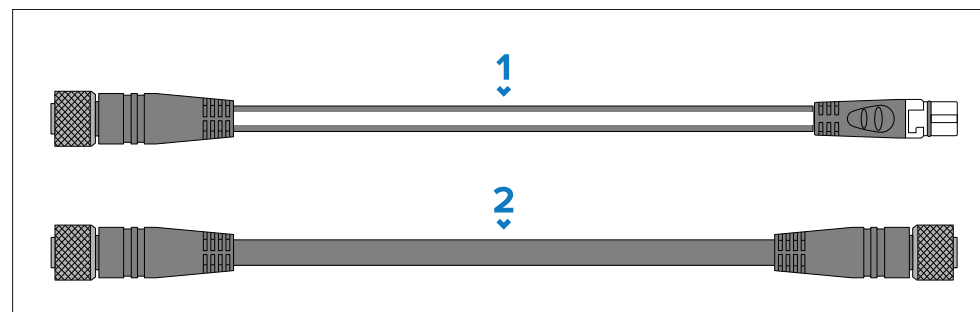

1. Use the supplied DeviceNet to SeaTalkng[®] adaptor cable to connect your product to an available spur connection on a SeaTalkng[®] backbone.
2. Alternatively you can connect your product to a NMEA 2000 backbone using a standard DeviceNet cable (not supplied).

Note:

1. The product must be connected to a correctly terminated backbone. You cannot connect your product directly to a MFD.
2. Refer to the instructions supplied with your SeaTalkng® / NMEA 2000 device for details on creating a backbone.

9.4 NMEA 0183 connection

The AIS700 can transmit and receive NMEA 0183 data, using the NMEA 0183 wires located on the power / data cable.

The AIS unit includes 2 bidirectional NMEA 0183 connections, configured as input/output pairs. One input/output pair is configured for high-speed NMEA 0183 connections (38,400 Baud), and is identified using the “NMEA HI” labels on the power cable wires. The second input/output pair is configured for low-speed NMEA 0183 connections (4,800 Baud), and is identified using the “NMEA LO” labels on the power cable wires.

Note:

It is possible to configure the baud rate for each NMEA 0183 port in the ProAIS software. However, this feature is intended **for diagnostic and troubleshooting purposes only**. The ProAIS2 software can be downloaded from the Raymarine website: www.raymarine.com/software

Important:

The AIS unit has its own GNSS (GPS) receiver. This GPS data can be multiplexed with the AIS data and output on the high speed (38,400) NMEA 0183 output. However, this feature is intended **for diagnostic and troubleshooting purposes only**. To prevent potential GPS data conflicts or loops and / or performance issues, **the AIS unit’s internal GPS receiver is intended to provide GPS data to the AIS unit only**. Therefore, the AIS unit’s GNSS (GPS) receiver should NOT be used to provide GNSS (GPS) data to multifunction displays or any other external device.

Typically, the AIS unit’s high speed (HI) (38,400 Baud) **output** wires are connected to an MFD’s NMEA 0183 input, and configured for 38,400 Baud, which is the Baud Rate required for AIS data transfer. The AIS unit’s low

speed (LO) (4,800 Baud) NMEA 0183 **input** wires are typically connected to a Heading sensor or other NMEA 0183 device, and configured for 4,800 baud rate.

For more information on the possible combination of data connections available on the AIS unit, refer to: [p.34 – Data connections overview](#)

As a general rule, when making NMEA 0183 connections using the AIS unit, be aware of the following:

- When data (e.g. GNSS) is sent to the AIS unit’s NMEA 0183 **input** set to a **low** speed Baud Rate (**4,800**), it cannot be **output** on the AIS unit’s NMEA 0183 connection *at the same Baud Rate*.
- When data (e.g. GNSS) is sent to the AIS unit’s NMEA 0183 **input** set to a **high** speed Baud Rate (**38,400**), it cannot be **output** on the AIS unit’s NMEA 0183 connection *at the same Baud Rate*.

Note:

For a list of supported NMEA 0183 sentences, refer to: [p.76 – NMEA 0183 supported sentences](#)

The following illustration identifies the NMEA 0183 input and output connections available on the AIS unit’s power cable:

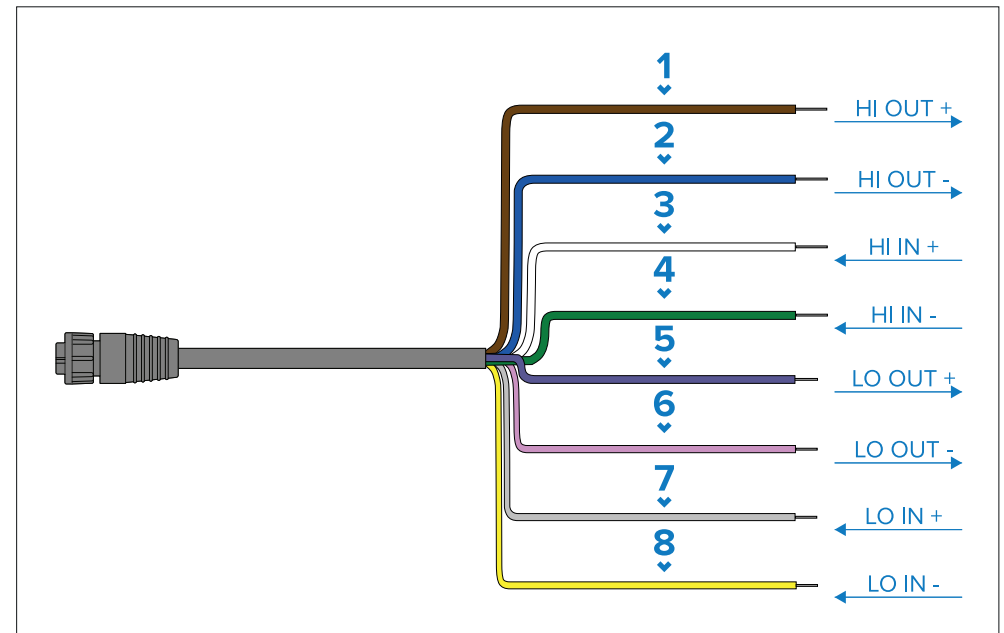

	Wire colour	Description
1	Brown	HI OUT +
2	Blue	HI OUT –
3	White	HI IN +
4	Green	HI IN –
5	Purple	LO OUT +
6	Pink	LO OUT –
7	Gray	LO IN +
8	Yellow	LO IN –

9.5 GPS (GNSS) antenna connection

Connect the supplied GNSS antenna to your AIS700 using the GNSS antenna connection. The antenna is fitted with a 10 m (33ft) cable for connecting to the AIS700.

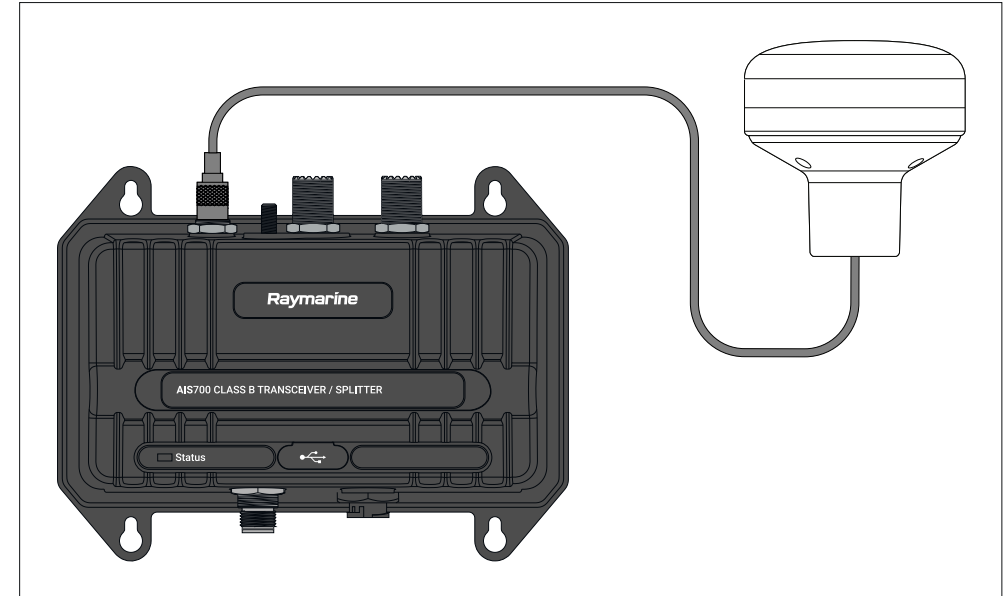

Important:

To avoid potential data conflicts or loops, avoid connecting the AIS unit to multiple (and different) data buses on an external unit **at the same time**:

- Do NOT connect the AIS unit to an MFD via NMEA 0183 **and** SeaTalkng / NMEA 2000 connections **at the same time**.
- Do NOT connect the AIS unit to a VHF Radio via NMEA 0183 **and** SeaTalkng / NMEA 2000 connections **at the same time**.
- Do NOT connect the AIS unit to a PC via NMEA 0183 **and** USB connections **at the same time**.

Note:

Do NOT connect any other antenna than the one supplied with your AIS700.

If the antenna is not connected or connected incorrectly, your AIS700 will operate in Silent mode. In this mode, the AIS700 will not transmit but will still receive.

Important:

If you are replacing a GPS antenna supplied with an older AIS receiver or an AIS700 with an early (low) serial number, please be aware that the mounting diameter (cutout) of the GPS receiver has changed, from Ø44 mm to Ø60 mm.

9.6 VHF antenna connection

Connect a VHF antenna (not supplied) to your AIS700 using the VHF antenna connection.

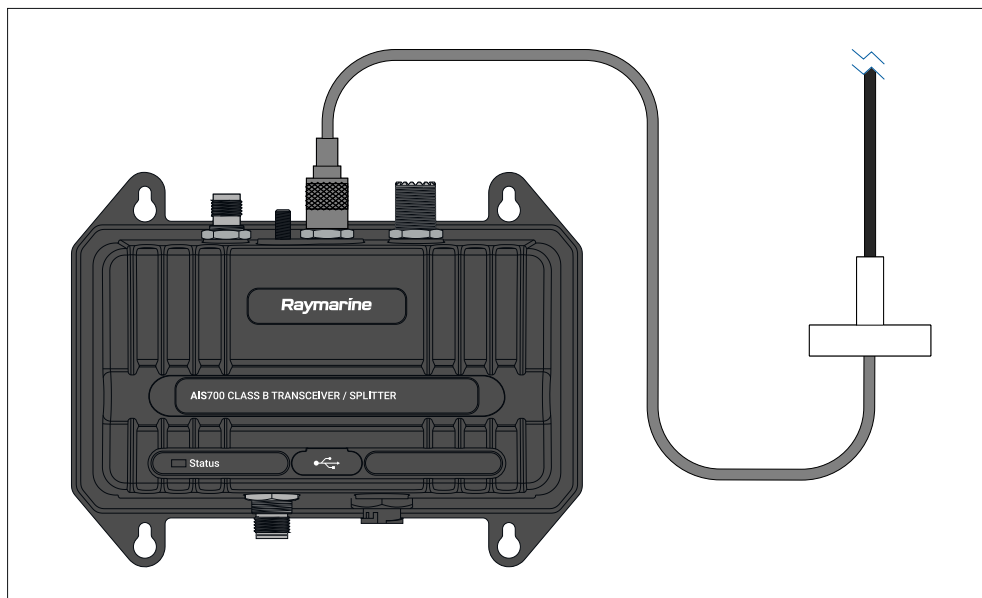

VHF antenna requirements

Important requirements related to the type and specification of the VHF antenna required for your AIS unit.

To ensure optimum antenna performance, adhere to the following guidelines:

- The use of a **wideband** VHF antenna is highly recommended, rather than an AIS-only antenna.
- The AIS700 requires a wideband antenna to provide good performance for both the AIS transceiver and a connected VHF radio utilizing the AIS700's integrated antenna splitter.
- Using a VHF antenna optimized for only AIS frequency operation may permanently damage the AIS700, as VHF radio transmissions are reflected back into the AIS700 due to the poor impedance match of the VHF antenna operating at VHF radio frequencies.
- Using a **non**-wideband VHF antenna optimized only for VHF radio frequencies may cause transmissions from the AIS transceiver to be

reflected back into the AIS700, due to the poor impedance match of the antenna and AIS transceiver frequencies. Although this will not damage the AIS700 (because AIS class B transmissions are of substantially lower power than VHF transmissions), it could result in the AIS700 triggering a system VSWR alarm.

- New VHF antennas are sold with a fixed cable length. The cable length partly determines the antenna performance, and therefore cutting the cable of an antenna can affect its performance and result in a high VSWR ratio and limited reception.

Recommended VHF antenna specifications

Specifications

Frequency band:	156.025 MHz to 162.025 MHz
VSWR (Voltage Standing Wave Ratio):	Should not exceed 2:1, across the entire frequency range
Impedance:	50 Ohm wideband
Gain:	3dBi Max
Connector type:	PL-259

9.7 VHF radio connection

For systems that include a VHF DSC radio, you can share the VHF antenna by connecting your Radio's VHF antenna connection to the VHF Radio connection on your AIS700. Connect your VHF antenna to the AIS700's VHF antenna connection.

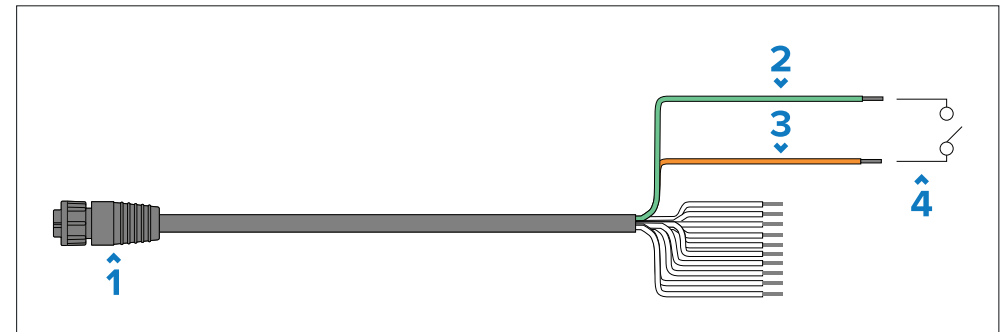
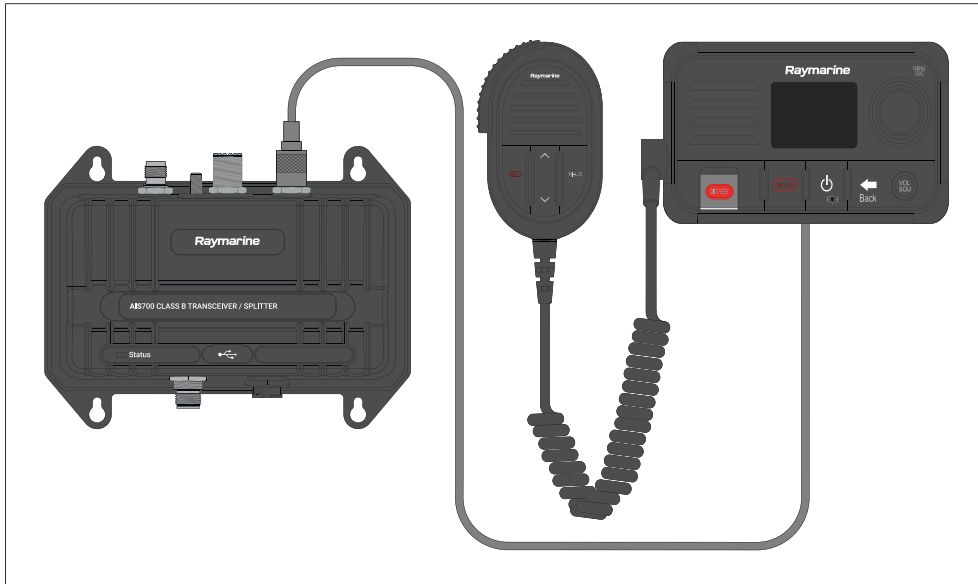

1. Power/data cable (supplied)
2. Light Green wire
3. Orange wire
4. Switch (not supplied)

Crimp or solder the wire connections and ensure suitable insulation from water ingress.

9.8 Silent mode switch connection

In Silent mode your AIS700 will stop transmitting position data and operate as a receiver only. Silent mode can be enabled using a connected MFD and by connecting a switch to the relevant wires on the Power/data cable. Please refer to your MFD's operation instructions for details on enabling silent mode.

Note:

A silent mode switch will override an MFD's Silent mode setting.

CHAPTER 10: POWER CONNECTIONS

CHAPTER CONTENTS

- 10.1 Power connection — page 42
- 10.2 Power distribution — page 42
- 10.3 Grounding — page 44
- 10.4 Power cable extension (12 / 24 V systems) — page 44

10.1 Power connection

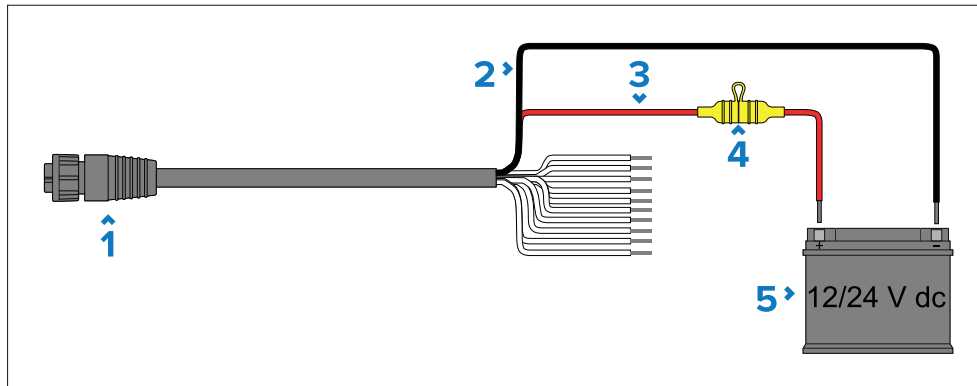

1. Power/data cable (supplied)
2. Black wire (negative) — connects to the power supply's negative terminal.
3. Red wire (positive) — connects to the power supply's positive terminal.
4. Waterproof fuse holder containing a suitably-rated inline fuse (**not supplied**), which must be fitted to the red positive wire — refer to the fuse ratings below.
5. Power source (12 / 24 V dc).

In-line fuse and thermal breaker ratings

The following in-line fuse and thermal breaker ratings apply to your product:

Inline fuse rating	Thermal breaker rating
3 A	3 A

Note:

- The suitable fuse rating for the thermal breaker is dependent on the number of devices you are connecting. If in doubt consult an authorized Raymarine dealer.
- Your product's power cable may have an in-line fuse fitted, if not then you must add an in-line fuse / breaker to the positive wire of your product's power connection.

10.2 Power distribution

Recommendations and best practice.

- The product is supplied with a power cable, either as a separate item or a captive cable permanently attached to the product. Only use the power cable supplied with the product. Do NOT use a power cable designed for, or supplied with, a different product.
- Refer to the *Power connection* section for more information on how to identify the wires in your product's power cable, and where to connect them.
- See below for more information on implementation for some common power distribution scenarios:

Important:

- When planning and wiring, take into consideration other products in your system, some of which (e.g. sonar modules) may place large power demand peaks on the vessel's electrical system, which may impact the voltage available to other products during the peaks.
- The information provided below is for guidance only, to help protect your product. It covers common vessel power arrangements, but does NOT cover every scenario. If you are unsure how to provide the correct level of protection, please consult an authorized dealer or a suitably qualified professional marine electrician.

Implementation — connection to distribution panel (Recommended)

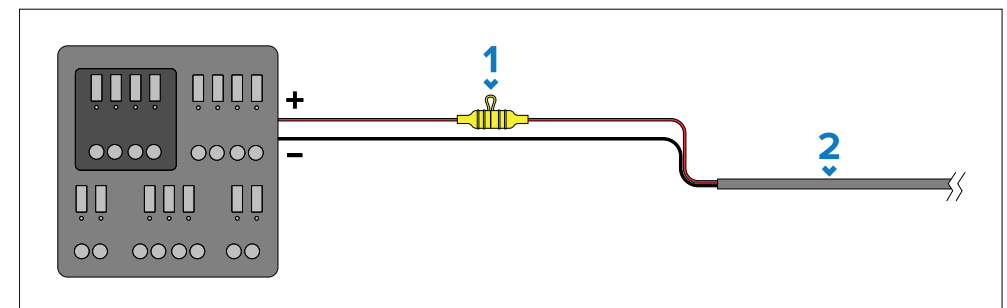

Item	Description
1	Waterproof fuse holder containing a suitably-rated inline fuse must be fitted. For suitable fuse rating, refer to: <i>Inline fuse and thermal breaker ratings</i> .
2	Product power cable.

- It is recommended that the supplied power cable is connected to a suitable breaker or switch on the vessel's distribution panel or factory-fitted power distribution point.
- The distribution point should be fed from the vessel's primary power source by 8 AWG (8.36 mm²) cable.
- Ideally, all equipment should be wired to individual suitably-rated thermal breakers or fuses, with appropriate circuit protection. Where this is not possible and more than one item of equipment shares a breaker, use individual inline fuses for each power circuit to provide the necessary protection.

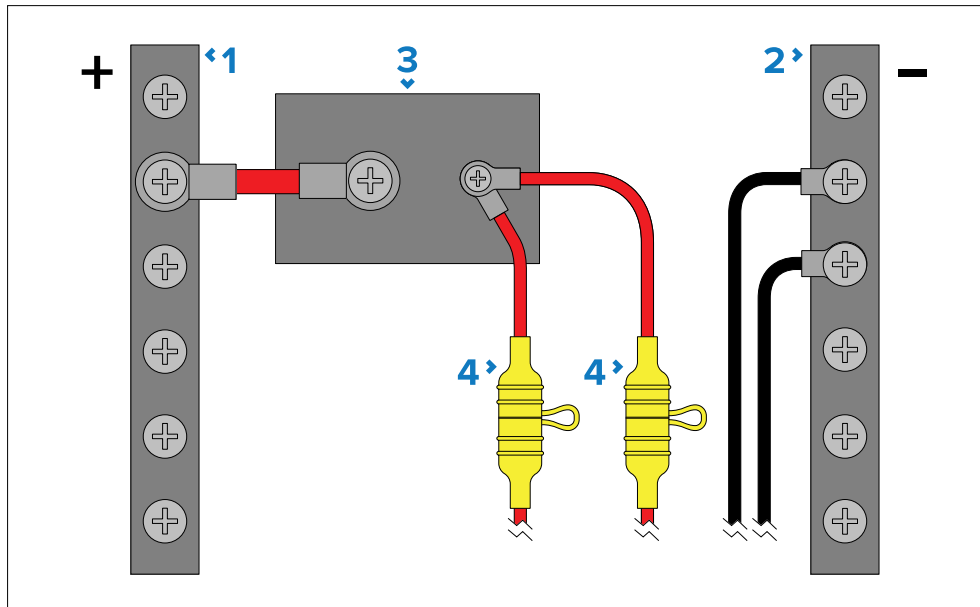

Item	Description
1	Positive (+) bar
2	Negative (-) bar

Item	Description
3	Circuit breaker
4	Waterproof fuse holder containing a suitably-rated inline fuse must be fitted. For suitable fuse rating, refer to: <i>Inline fuse and thermal breaker ratings</i> .

Important:

Observe the recommended fuse / breaker ratings provided in the product's documentation, however be aware that the suitable fuse / breaker rating is dependent on the number of devices being connected.

Implementation – direct connection to battery

- Where connection to a power distribution panel is not possible, the power cable supplied with your product may be connected directly to the vessel's battery, via a suitably rated fuse or breaker.
- The power cable supplied with your product does NOT include a separate drain wire. Therefore, only the power cable's red and black wires need to be connected.
- If the power cable is NOT supplied with a fitted inline fuse, you MUST fit a suitably rated fuse or breaker between the red wire and the battery's positive terminal.
- Refer to the inline fuse ratings provided in the product's documentation.
- If you need to extend the length of the power cable supplied with your product, ensure you observe the dedicated *Power cable extensions* advice provided in the product's documentation.

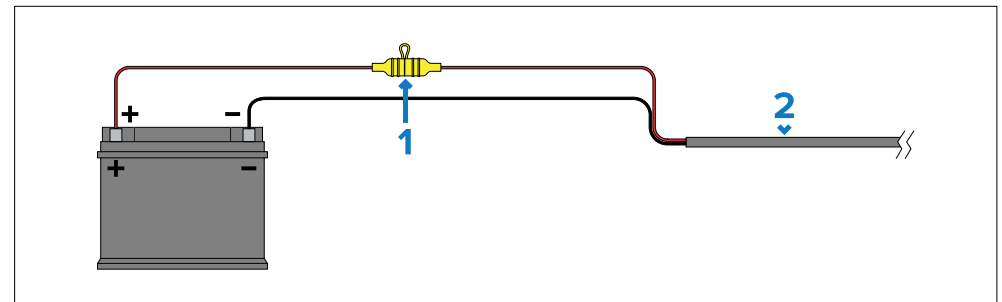

Item	Description
1	Waterproof fuse holder containing a suitably-rated inline fuse must be fitted. For suitable fuse rating, refer to: <i>Inline fuse and thermal breaker ratings</i> .
2	Product power cable.

More information

It is recommended that best practice is observed in all vessel electrical installations, as detailed in the following standards:

- BMEA Code of Practice for Electrical and Electronic Installations in Boats
- NMEA 0400 Installation Standard
- ABYC E-11 AC & DC Electrical Systems on Boats
- ABYC A-31 Battery chargers and Inverters
- ABYC TE-4 Lightning Protection

10.3 Grounding

Energy generated by Near-Lightning Strikes (NLS) and atmospheric static build-up can be conducted by the product, via the VHF antenna. To ensure that this energy is safely discharged, the grounding stud connection located on the product MUST be connected (via the supplied grounding strap) to the vessel battery's 0V negative terminal.

Failure to connect the grounding stud to the vessel battery's 0V negative terminal may cause permanent damage to the product and invalidate your product's warranty.

Important:

This is NOT an optional connection.

Note:

If your vessel is constructed of an electrically conductive material such as steel, aluminium or carbon fibre, you MUST ensure that the VHF antenna's outer mount is insulated / isolated from the vessel structure.

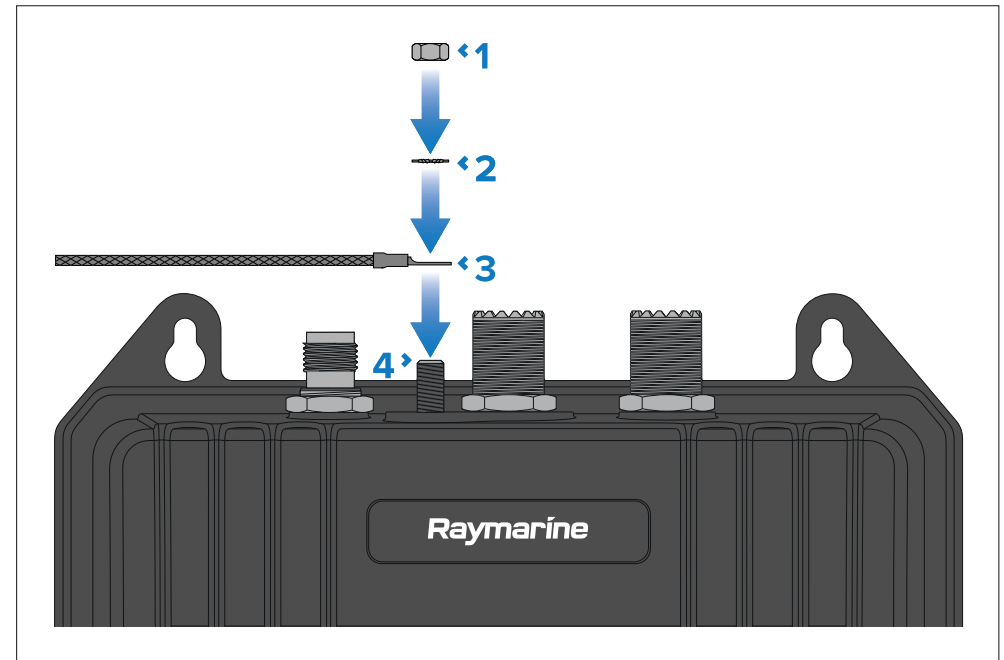

1. M5 Nut (supplied).
2. M5 Shakeproof washer (supplied).
3. Grounding strap (supplied), connected to vessel battery's 0V negative battery terminal.
4. Grounding stud.

10.4 Power cable extension (12 / 24 V systems)

If you need to extend the length of the power cable supplied with your product, ensure you observe the following advice:

- The power cable for each unit in your system should be run as a separate, single length of 2-wire cable from the unit to the vessel's battery or distribution panel.
- Ensure that the extension cable is of a sufficient gauge for the supply voltage and the total load of the device and the length of the cable run. Refer to the following table for typical **minimum** power cable wire gauges:

Cable length in meters (feet)	Wire gauge in AWG (mm ²) for 12 V supply	Wire gauge in AWG (mm ²) for 24 V supply
<8 (<25)	16 (1.31 mm ²)	18 (0.82 mm ²)
16 (50)	14 (2.08 mm ²)	18 (0.82 mm ²)
24 (75)	14 (2.08 mm ²)	16 (1.31 mm ²)
>32 (>100)	14 (2.08 mm ²)	16 (1.31 mm ²)

Important:

Be aware that some products in your system (such as sonar modules) can create voltage peaks at certain times, which may impact the voltage available to other products during the peaks.

Important:

To ensure power cables (including any extension) are of a sufficient gauge, ensure that there is a continuous **minimum** voltage of **10.8 V dc** at the end of the cable where it enters the product's power connector, even with a fully flat battery at 11 V dc. (Do not assume that a flat battery is at 0 V dc. Due to the discharge profile and internal chemistry of batteries, the current drops much faster than the voltage. A "fully flat" battery still shows a positive voltage, even if it doesn't have enough current to power your device.)

CHAPTER 11: SET UP AND CONFIGURATION

CHAPTER CONTENTS

- 11.1 IMPORTANT — Configure before use — page 47
- 11.2 AIS licensing and MMSI — page 47
- 11.3 Licensing and MMSI issuing authorities — page 47
- 11.4 Configuration — page 50
- 11.5 Viewing AIS data on a display — page 52
- 11.6 Software updates — page 53

11.1 IMPORTANT — Configure before use

Before first use this product **must** be correctly configured using a PC (Personal Computer) and the ProAIS2 software, which can be downloaded from the Raymarine website: www.raymarine.com/software

- Failure to configure the product will prevent correct operation.
- Configuration **MUST** include programming the product with an MMSI number. In some regions (such as the United States), the MMSI **must** be programmed by a qualified dealer or installer.
- Once the MMSI number has been entered using the ProAIS2 software and the configuration saved (via the “Write Configuration” option), the MMSI number cannot be subsequently changed, without returning the unit to an authorized Raymarine dealer for reprogramming. Always check the MMSI number before saving the configuration.
- Incorrect / incomplete configuration can cause erroneous data and prevent your product from transmitting.
- If an MMSI number is not programmed the product will operate as an AIS receiver only and will **NOT** transmit AIS information for your vessel.

11.2 AIS licensing and MMSI

Prior to using this product for the first time, please check your national requirements for both operator and equipment licensing.

Licensing

In many countries, the licensing for the use of AIS equipment is included in the **Ship Station license** and **Operator's license** issued for VHF radios.

However, even if you already have a Ship Station license and Operator's license for a VHF radio, **some countries may require a separate license for AIS equipment use.**

Important:

It is your responsibility to determine whether a license is required in your area before operating this equipment.

MMSI

An MMSI is a 9 digit number which is sent over a radio frequency channel in order to identify the originating vessel / station. **Before commencing installation ensure you have obtained an MMSI number for your vessel.**

[Set up and configuration](#)

This is a mandatory requirement. If your vessel already has an MMSI number (used for a VHF DSC radio, for example), then the same MMSI number must be used to program your AIS equipment.

Important:

In some areas, a radio operator licence is required before an MMSI number will be issued. If an MMSI number is not entered, your product can only be used in Silent Mode and will operate as a receiver only.

In the United States of America (USA), the MMSI and Static Data must be entered only by a Raymarine® dealer or other appropriately qualified installer of marine communications equipment for marine vessels.

In the USA, the user is NOT authorized to do this.

In Europe and other parts of the world outside of the United States of America, the MMSI and Static data can be set up by the user.

Important:

Once the MMSI number has been entered using the ProAIS2 software and the configuration saved (via the “Write Configuration” option), the MMSI number cannot be subsequently changed, without returning the unit to an authorized Raymarine dealer for reprogramming. Always check the MMSI number before saving the configuration.

For a list of issuing authorities for licences and MMSI numbers in each region, refer to: [p.47 — Licensing and MMSI issuing authorities](#)

11.3 Licensing and MMSI issuing authorities

The following table lists the relevant issuing authority for licences and MMSI numbers in each region, along with a link to the relevant website. Many authorities allow you to apply for a license online.

Country & regulatory authority	Website
<u>Argentina (AR):</u> Ente Nacional de Comunicaciones	http://www.enacom.gob.ar
<u>Australia (AU):</u> Australian Communications and Media Authority	http://www.acma.gov.au/

Country & regulatory authority	Website
<u>Austria (AT):</u> Austrian Regulatory Authority for Broadcasting and Telecommunications	http://www.rtr.at
<u>Belgium (BE):</u> Belgian Institute for Postal services and Telecommunications (BIPT)	http://www.bipt.be
<u>Brazil (BR):</u> Agencia Nacional de Telecomunicacoes	http://www.anatel.gov.br
<u>Bulgaria (BG):</u> Communications Regulation Commission	http://www.crc.bg
<u>Canada (CA):</u> Industry Canada	https://www.ic.gc.ca/eic/site/smt-gst.nsf/eng/home
<u>China (ZH):</u> Ministry of Information Industry	http://www.mii.gov.cn
<u>Costa Rica (CR):</u> Superintendencia de Telecomunicaciones	http://sutel.go.cr
<u>Croatia (HR):</u> Croatian Post and Electronic Communications Agency	http://www.hakom.hr/default.aspx?id=7
<u>Cyprus (CY):</u> Office of Electronic Communications & Postal Regulation	http://www.ocecpr.org.cy/nqcontent.cfm?a_id=767&tt=ocecpr&lang=gr
<u>Czech Republic (CZ):</u> The Czech Telecommunication Office	http://www.ctu.eu/main.php?pageid=178

Country & regulatory authority	Website
<u>Denmark (DK):</u> Danish Energy Agency	https://ens.dk/en
<u>Estonia (EE):</u> Estonian Competition Authority	http://www.konkurentsiamet.ee/?lang=en
<u>Finland (FI):</u> Finnish Communications Regulatory Authority	http://www.ficora.fi/en
<u>France (FR):</u> Autorité de Régulation des Communications Électroniques et des Postes	http://www.arcep.fr
<u>Germany (DE):</u> Bundesnetzagentur	http://www.bundesnetzagentur.de
<u>Greece (EL):</u> Hellenic Telecommunications and Post Commission	http://www.eett.gr/opencms/opencms/EETT_EN/index.html
<u>Holland (NL):</u> Autoriteit Consument & Markt	https://www.acm.nl/nl
<u>Hong Kong (HK):</u> Office of Communications Authority	http://www.ofca.gov.hk
<u>Hungary (HU):</u> National Media and Infocommunication Authority	http://www.nmhh.hu
<u>Iceland (IS):</u> Post and Telecom Administration	http://www.pfs.is/default.aspx?cat_id=101
<u>Indonesia (ID):</u> Indonesian Telecommunications Regulatory Authority	http://www.brti.or.id

Country & regulatory authority	Website
<u>Ireland (IE):</u> Commission for Communications Regulation	http://www.comreg.ie
<u>Isle of Man (IM):</u> Communications Commission	http://www.gov.im/government/boards/cc.xml
<u>Italy (IT):</u> Autorità per le Garanzie nelle Comunicazioni	http://www.agcom.it
<u>Jamaica (JM):</u> Spectrum Management Authority	http://www.sma.gov.jm
<u>Japan (JP):</u> Ministry of Internal Affairs and Communications	http://www.soumu.go.jp/english/index.html
<u>Korea, South (KR):</u> Korea Communications Commission	http://eng.kcc.go.kr
<u>Lichtenstein (LI):</u> Office for Communications	http://www.llv.li/amtsstellen/llv-ak-english-page.htm
<u>Lithuania (LT):</u> Communications Regulatory Authority	http://www.rtt.lt/en/home.html
<u>Luxembourg (LU):</u> Institut luxembourgeois de régulation	http://www.ilr.public.lu
<u>Latvia (LV):</u> Elektronisko sakaru direkcija	https://www.vases.lv/lv/content/juras-sakaru-atlaujas
<u>Malaysia (MY):</u> Malaysian Communications and Multimedia Commission	http://www.mcmc.gov.my

Country & regulatory authority	Website
<u>Malta (MT):</u> Malta Communications Authority	http://www.mca.org.mt
<u>Mexico (MX):</u> Instituto Federal de Telecomunicaciones	http://www.ift.org.mx
<u>New Zealand (NZ):</u> Commerce Commission of New Zealand	http://www.comcom.govt.nz
<u>Norway (NO):</u> Norwegian Communications Authority	http://www.nkom.no
<u>Panama (PA):</u> Autoridad Nacional de los Servicios Públicos	http://www.asep.gob.pa/default.asp
<u>Poland (PL):</u> Prezes Urzędu Komunikacji Elektronicznej	http://www.uke.gov.pl
<u>Portugal (PT):</u> Autoridade Nacional de Comunicações	https://www.anacom.pt
<u>Romania (RO):</u> National Authority for Management and Regulation in Communications of Romania	http://www.ancom.org.ro/en
<u>Russia (RU):</u> Ministry of Telecom and Mass Communications of the Russian Federation	https://minsvyaz.ru/en

Country & regulatory authority	Website
<u>Saudi Arabia (SA):</u> Communications and Information Technology Commission (Saudi Arabia)	http://www.citc.gov.sa
<u>Singapore (SG):</u> Info-communications Media Development Authority of Singapore	https://www.imda.gov.sg
<u>Slovenia (SI):</u> Agency for communication networks and services of the Republic of Slovenia	http://www.akos-rs.si/akos-ang
<u>Slovakia (SK):</u> Telecommunications Regulatory Authority of the Slovak Republic	http://www.teleoff.gov.sk/index.php?ID=9
<u>South Africa (ZA):</u> Independent Communications Authority of South Africa	http://www.icasa.org.za
<u>Spain (ES):</u> Comisión Nacional de los Mercados y la Competencia	https://www.cnmc.es/en
<u>Sweden (SE):</u> Swedish Post and Telecom Authority	http://www.pts.se
<u>Switzerland (CH):</u> Office fédéral de la communication	http://www.bakom.admin.ch/themen/frequenzen/00689/01563/index.html?lang=fr
<u>Taiwan (TW):</u> National Communications Commission	http://www.ncc.gov.tw/english/index.aspx
<u>Thailand (TH):</u> National Broadcasting and Telecommunications Commission	http://nbtc.go.th/wps/portal/NTC/eng

Country & regulatory authority	Website
<u>Turkey (TR):</u> Information And Communication Technologies Authority	http://eng.btk.gov.tr
<u>United Arab Emirates (AE):</u> Telecommunications Regulatory Authority	http://www.tra.ae
<u>United Kingdom and Northern Ireland (UK (NI)):</u> OFCOM	http://www.ofcom.org.uk
<u>United States (US):</u> FCC	https://www.fcc.gov/bureau-divisions/mobility-division/ship-radio-stations#block-menu-block-4

11.4 Configuration

The AIS700 should be configured prior to installation, using a PC/laptop, USB Micro-B cable, and the **proAIS2** software.

Note:

The ProAIS2 software can be downloaded from the Raymarine website:
www.raymarine.com/software

The manner in which configuration is carried out depends on the legal requirements of your geographical location.

USA

In the USA, it is a legal requirement that the configuration is performed by a qualified dealer or installer.

You can use the **proAIS2** PC software to check the vessel data programmed into your AIS700. If this information is incorrect, please contact your Raymarine dealer.

Areas outside of USA

In areas outside of the USA, use the **proAIS2** PC software to configure your AIS700.

Note:

If configuring after installation ensure any MFDs on the same network are switched off first, otherwise you will not be able to correctly configure your AIS700.

The following vessel-related static data should be configured:

- MMSI number
- Vessel name
- Vessel call sign
- Vessel dimensions including AIS GNSS (GPS) antenna location
- Vessel type

A valid 9 digit MMSI number must be entered. Invalid numbers will not be accepted. Only the *Vessel call sign* field is entirely optional.

Important:

Once the MMSI number has been entered using the ProAIS2 software and the configuration saved (via the “Write Configuration” option), the MMSI number cannot be subsequently changed, without returning the unit to an authorized Raymarine dealer for reprogramming. Always check the MMSI number before saving the configuration.

Installing ProAIS2 software and USB drivers

Before using your AIS unit for the first time, you **must** configure the unit using the ProAIS software, via a PC, Mac or laptop connected by USB. This requires downloading and installing the ProAIS2 application and USB drivers, as described below:

1. Download the ProAIS2 software from the Raymarine website: www.raymarine.com/software
2. Double click on the *setup.exe* file to launch the installer.
3. Follow the on screen installation instructions, ensuring that the option to install USB drivers is selected when presented.
4. Once installed the AIS unit can be connected to the PC/laptop. The USB drivers will be installed automatically and the AIS unit will appear as a new COM port device.

5. Launch ProAIS2 by navigating to the ProAIS2 folder accessible from the Start menu or applications launcher of your PC/laptop.

Configuring using proAIS2

Important:

In the United States of America, it is a violation of the rules of the Federal Communications Commission to input an MMSI that has not been properly assigned to the end user or to otherwise input any inaccurate data in this device. The MMSI and Static Data must be entered only by a Raymarine dealer or other appropriately qualified installer of marine communications equipment on board vessels.

Ensure you check the regulations for your location to ensure you are allowed to configure MMSI data on your unit.

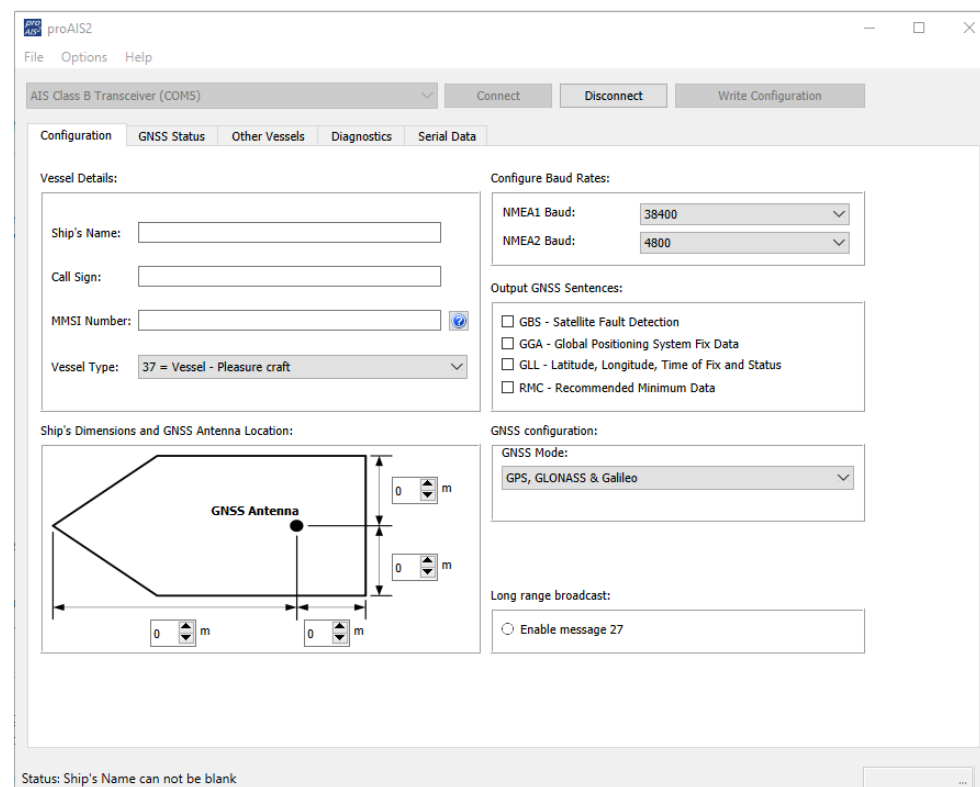

With the proAIS2 software open on your PC:

1. Select the AIS device from the drop down list at the top of the page.
2. Click [Connect].
3. **IMPORTANT:** Enter your vessel's details, including MMSI in the relevant fields.

If an MMSI number has been entered for the first time, it cannot be subsequently changed once the "Write Configuration" option is used. Always check the MMSI number before saving the configuration.

4. Select a [Vessel Type] appropriate for your vessel from the drop down list.
5. If required, set the baud rate for your NMEA 0183 ports.

This option is intended for diagnostics purposes only.

6. Ensure that the built-in GNSS receiver is not outputting NMEA sentences (i.e. ensure GBS, GGA, GLL and RMC boxes are not ticked).

The GNSS receiver built-in to the AIS700 is intended to provide GNSS data to the AIS unit only, outputting this data can cause data conflicts. The ability to output these sentences is intended for diagnostics purposes only.

7. **IMPORTANT:** Enter your vessel's dimensions and GNSS (GPS) antenna location in the relevant fields. This dictates how large your vessel appears on AIS traffic websites, such as www.marinetraffic.com.
8. Ensure that the option selected in the [GNSS Mode] dropdown list reflects the range of GNSS (GPS) satellite systems that you need to use. If in doubt, keep the default option.
9. The *Enable Message 27* option for the [Long range broadcast] setting is used for long range detection when outside the range of coastal receivers. Message 27 transmissions are on different channels to the standard AIS channels, and are primarily used for satellite reception. This option should only be selected if you are likely to be boating in a location that is outside the range of coastal receivers.
10. Click [Write Configuration] to save your configuration settings.

If an MMSI number has been entered for the first time, it cannot be subsequently changed once the "Write Configuration" option is used. Always check the MMSI number before saving the configuration.

11. Click [Disconnect].

11.5 Viewing AIS data on a display

To view the AIS data received by your AIS unit, the unit's supplied passive GPS antenna must be connected, and you must also connect the AIS unit to a multifunction display or chartplotter with its own source of GPS data. The AIS unit must be connected to the display via SeaTalkng/NMEA 2000, or high-speed NMEA 0183. Alternatively, the AIS unit can be connected to a PC/laptop (via USB) with its own source of GPS data, running suitable AIS-compatible software.

The multifunction display, chartplotter, or PC/laptop must be configured to display AIS targets. The procedure for configuring a Raymarine MFD is provided in the following sections. For configuring AIS on third-party displays/chartplotters/PCs/laptops, please refer to the relevant Operation instructions for that product.

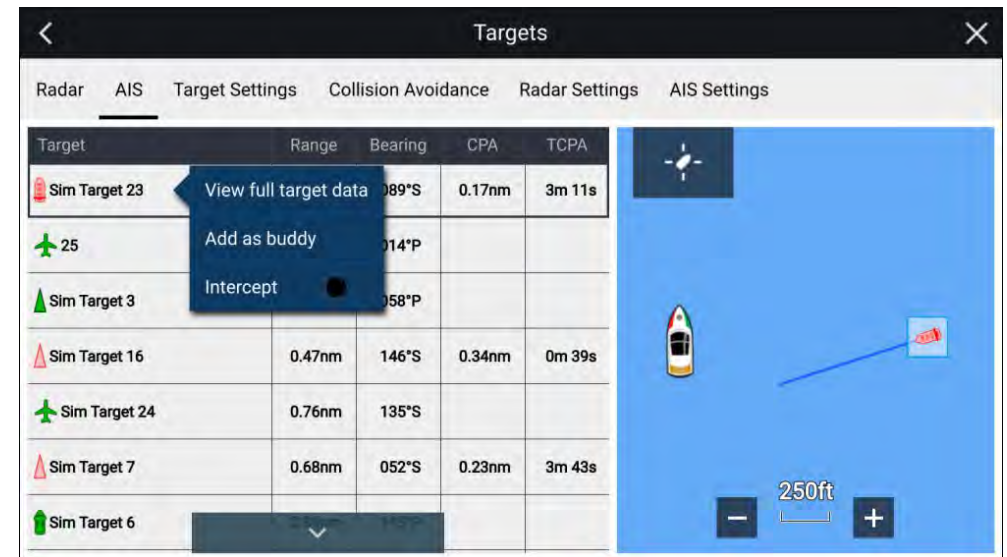

Note:

The screenshot shown above reflects how AIS targets are listed in LightHouse 3 / LightHouse 4. The display of AIS target information in other applications will vary.

Enabling AIS targets in LightHouse 3 / LightHouse 4

In the Chart application:

- Select: [*Menu > Targets > AIS Settings*]
- Ensure that [*Show AIS targets in Chart*] is selected.

Enabling AIS targets in LightHouse 2

In the Chart application:

- Select: [*Menu > Presentation > Overlays*]
- Ensure that [*AIS*] is selected.

11.6 Software updates

Raymarine periodically releases software updates for its products. These updates can provide new and enhanced features and also improve product performance and usability. You should ensure that you have the latest software for your products by regularly checking the website for new software. The software update process requires a compatible MFD powered by LightHouse™ 2 release 13 or greater, or LightHouse™ 3.

Check the Raymarine website regularly for software updates for your products: www.raymarine.com/software.

The MFD used to perform the software update must be the designated Data master and be connected via SeaTalkng® / NMEA 2000 to the product being updated.

Please refer to Raymarine website for instructions on how to use your MFD to perform a software update: www.raymarine.com/software

If in doubt as to the correct procedure for updating your product software, refer to your dealer or Raymarine technical support.

CHAPTER 12: MAINTENANCE

CHAPTER CONTENTS

- 12.1 Routine equipment checks — page 55
- 12.2 Product cleaning — page 55

12.1 Routine equipment checks

It is recommended that you perform the following routine checks, on a regular basis, to ensure the correct and reliable operation of your equipment:

- Examine all cables for signs of damage or wear and tear.
- Check that all cables are securely connected.

12.2 Product cleaning

Best cleaning practices.

When cleaning products:

- Switch off power supply.
- Use a clean damp cloth to wipe clean.
- Do NOT use: abrasive, acidic, ammonia, solvent or other chemical based cleaning products.
- Do NOT use a jet wash.

CHAPTER 13: TROUBLESHOOTING

CHAPTER CONTENTS

- 13.1 Power up troubleshooting — page 57
- 13.2 AIS data troubleshooting — page 57
- 13.3 VSWR Alarm troubleshooting — page 59
- 13.4 Data conflicts and data loops — page 59
- 13.5 LED Status indicator — page 59
- 13.6 USB connection troubleshooting — page 59

13.1 Power up troubleshooting

Problems at power up and their possible causes and solutions are described here.

Product does not turn on or keeps turning off:

Possible causes	Possible solutions
Blown fuse / tripped breaker	<ol style="list-style-type: none"> 1. Check the condition of fitted fuses and breakers and connections, replace if necessary. 2. Ensure fitted fuse rating is correct (3 A). 3. If fuse keeps blowing check for cable damage, broken connector pins or incorrect wiring.
Poor / damaged / insecure power supply cable / connections	<ol style="list-style-type: none"> 1. Check that the power cable connector is fully inserted into the product and locked in position. 2. Check the power supply cable and connectors for signs of damage or corrosion, replace if necessary. 3. With the product powered on, try flexing the power cable near to the product connector to see if this causes the product to re-boot/lose power, replace if necessary. 4. Check the product's power supply voltage, the condition of the battery terminals and power supply cables, ensuring connections are secure, clean and free from corrosion, replace if necessary. 5. With the product powered on and where applicable, transmitting, using a multi-meter, check for a voltage drop across all connectors /fuses etc, and replace if necessary.
Incorrect power connection	The power supply may be wired incorrectly, ensure the installation instructions have been followed.
Power source insufficient	Check that your power supply (battery or distribution panel) is providing a minimum of 10.2 V to the product.

Product will not boot up (re-boot loop):

Possible causes	Possible solutions
Power supply and connection	See possible solutions from 'Products does not turn on or keeps turning off' above.
Software corruption	In the unlikely event that the product's software has become corrupted, please try re-flashing the product with the latest software from the Raymarine website: www.raymarine.com/software

13.2 AIS data troubleshooting

No AIS targets shown on the display:

Possible causes	Possible solutions
Data / network problem	Review and carry out solutions detailed in the <i>Missing, conflicting or erratic data</i> table below.
VHF antenna fault	Check the VHF antenna is properly connected and is not short circuiting to the vessel's structure.
GNSS (GPS) antenna fault	Check the GNSS (GPS) antenna is properly connected and is installed in an appropriate location (e.g.: with a clear view of the sky).
AIS feature not enabled on display	Refer to the Operation instructions for your display to identify how to enable the AIS feature.
MFD set to display Dangerous or Buddy targets only and none are in range of your vessel.	Refer to the Operation instructions for your display to identify how to enable the display of all AIS targets.
No AIS equipped vessels in range.	Wait for more vessels to be in your vicinity and check again (e.g.: in a marina).

Missing, conflicting or erratic data:

Possible causes	Possible solutions
MMSI number and / or static data not configured.	Configure the product with an MMSI number and correct static data using the proAIS2 software and a PC. Refer to 11.4 Configuration for details.
AIS configuration, static data is not being saved.	Disconnect all connections then connect only the USB cable to a PC and retry configuration.
AIS hardware not detected by display	<ul style="list-style-type: none"> • Check all connections are secure and free from damage; replace if required. • When connected using NMEA 0183, ensure the port used to connect the product to your MFD is set to 38,400 baud rate. Also check that the port is configured to output AIS data (usually Port 1 outputs AIS data by default). • Ensure the MFD is connected to the same SeaTalkng® / NMEA 2000 network as your display, or that the MFD is connected directly to the relevant NMEA 0183 connections.
SeaTalkng® / NMEA 2000 and NMEA 0183 connected at the same time, to the same device	Ensure only one connection is made, either SeaTalkng® / NMEA 2000 OR NMEA 0183.
Multiple AIS receivers/transceivers connected and operating	If your system includes more than one AIS receiver/transceiver, ensure that only one is powered on or transmitting.

VHF antenna requirements

Important requirements related to the type and specification of the VHF antenna required for your AIS unit.

To ensure optimum antenna performance, adhere to the following guidelines:

- The use of a **wideband** VHF antenna is highly recommended, rather than an AIS-only antenna.

- The AIS700 requires a wideband antenna to provide good performance for both the AIS transceiver and a connected VHF radio utilizing the AIS700's integrated antenna splitter.
- Using a VHF antenna optimized for only AIS frequency operation may permanently damage the AIS700, as VHF radio transmissions are reflected back into the AIS700 due to the poor impedance match of the VHF antenna operating at VHF radio frequencies.
- Using a **non**-wideband VHF antenna optimized only for VHF radio frequencies may cause transmissions from the AIS transceiver to be reflected back into the AIS700, due to the poor impedance match of the antenna and AIS transceiver frequencies. Although this will not damage the AIS700 (because AIS class B transmissions are of substantially lower power than VHF transmissions), it could result in the AIS700 triggering a system VSWR alarm.
- New VHF antennas are sold with a fixed cable length. The cable length partly determines the antenna performance, and therefore cutting the cable of an antenna can affect its performance and result in a high VSWR ratio and limited reception.

Recommended VHF antenna specifications

Specifications	
Frequency band:	156.025 MHz to 162.025 MHz
VSWR (Voltage Standing Wave Ratio):	Should not exceed 2:1, across the entire frequency range
Impedance:	50 Ohm wideband
Gain:	3dBi Max
Connector type:	PL-259

13.3 VSWR Alarm troubleshooting

If you experience regular VSWR alarms try the troubleshooting guidance below.

Possible causes	Possible solutions
Incorrect antenna in use.	Check that your antenna meets the required VHF antenna specification that can be found in the product documentation.
Antenna short or open circuit.	Check antenna for short or open circuit, repair or replace as necessary.
Product running an older version of software.	Software version 1.09 included Improvements to Antenna fault detection (VSWR alarm).

13.4 Data conflicts and data loops

To avoid potential data conflicts and data loops, products should not be connected to the same device using more than one network protocol.

Important:

- Do NOT connect to an MFD or VHF radio using NMEA 0183 **and** SeaTalkng® / NMEA 2000 connections at the same time.
- Do NOT connect to a PC using NMEA 0183 **and** USB connections at the same time.
- If you are connecting to a VHF Radio that has built-in AIS, you **must** first disable the VHF Radio's AIS function, before connecting it to the AIS unit (or the same data network). Refer to your Radio's documentation for details on disabling the VHF Radio's AIS function.

13.5 LED Status indicator

The LED status indicator on the transceiver provides an indication of product status.

Color	Status
Green	Transceiver is powered up and operating normally.
Amber	Transceiver is not transmitting. <ul style="list-style-type: none">• Wait at least 30 minutes to check that a 'Quiet time' has not been requested by the local authority.
Red	Transceiver fault / MMSI number not programmed. <ul style="list-style-type: none">• Check MMSI number and static data has been correctly configured.• Check GNSS antenna is properly connected and has a clear unobstructed view of the sky.• Check the VHF antenna is properly connected and is not short circuiting to the vessel structure.• Check that power supply is at the correct voltage (12 V dc or 24 V dc).• Excessive difference between Heading from an input device, and COG.
Blue	Transceiver is running in silent mode (not transmitting). To disable silent mode: <ul style="list-style-type: none">• Check the AIS Silent mode setting on your MFD.• Check the position of the dedicated Silent mode switch, if fitted (the switch will override the MFD setting).• Where no dedicated switch is fitted, check that the Light Green and Orange wires on the power/data cable are not shorting together.

13.6 USB connection troubleshooting

If you encounter issues connecting the AIS unit to a PC/laptop via USB, try changing the USB cable in the first instance. If that does not resolve your issue, try using a different USB port, and also avoid using ports on USB hubs.

CHAPTER 14: TECHNICAL SUPPORT

CHAPTER CONTENTS

- 14.1 Product returns process — page 61
- 14.2 Raymarine product support and servicing — page 62
- 14.3 Learning resources — page 63

14.1 Product returns process

Many returned products are found to be not faulty. Before returning your product to Raymarine, please first conduct some basic troubleshooting to get up and running with your product. The Raymarine Product Support team is also available to take you step-by-step through any issues you might have.

1. Check all connections and power supply.
2. Ensure that the product is grounded via its dedicated grounding lug using the supplied grounding strap, in accordance with the requirements detailed in the following section: [p.44 — Grounding](#)
3. Ensure that the VHF antenna's specification meets the requirements detailed in the following section: [p.58 — VHF antenna requirements](#)
4. Ensure that the VHF and GNSS (GPS) antennas are operating correctly and installed in accordance with the instructions provided.
5. Ensure that the AIS unit has been programmed with an MMSI number.
6. Ensure that you have configured static data using the ProAIS2 software, which is available for download on the Raymarine website: www.raymarine.com/software
7. Connect the AIS receiver/transceiver to a PC and check the ProAIS2 diagnostics page for any faults.
8. Check that your display is compatible with your AIS receiver/transceiver.
9. Ensure that your display software is up to date. The latest software is available for download on the Raymarine website: www.raymarine.com/software
10. Check the LED status indicator against the diagnostics section of the product manual.
11. Read the entire product manual and troubleshooting information.
12. If the above actions do not resolve your problems, please call Raymarine Service and Support to obtain a Warranty Ref. No.; refer to the product return information on the Raymarine website: www.raymarine.com/support

Note:

The above actions need to be completed prior to Raymarine accepting the unit back under warranty.

14.2 Raymarine product support and servicing

Raymarine provides a comprehensive product support service, as well as warranty, service, and repairs. You can access these services through the Raymarine website, telephone, and e-mail.

Product information

If you need to request service or support, please have the following information to hand:

- Product name.
- Product identity.
- Serial number.
- Software application version.
- System diagrams.

You can obtain this product information using diagnostic pages of the connected display.

Servicing and warranty

Raymarine offers dedicated service departments for warranty, service, and repairs.

Don't forget to visit the Raymarine website to register your product for extended warranty benefits: <https://www.raymarine.com/en-us/support/product-registration>

United Kingdom (UK), EMEA, and Asia Pacific:

- E-Mail: emea.service@raymarine.com
- Tel: +44 (0)1329 246 932

United States (US):

- E-Mail: rm-usrepair@flir.com
- Tel: +1 (603) 324 7900

Web support

Please visit the "Support" area of the Raymarine website for:

- **Manuals and Documents** — <http://www.raymarine.com/manuals>
- **Technical support forum** — <https://raymarine.custhelp.com/app/home>
- **Software updates** — <http://www.raymarine.com/software>

Worldwide support

United Kingdom (UK), EMEA, and Asia Pacific:

- Help desk: <https://raymarine.custhelp.com/app/home>
- Tel: +44 (0)1329 246 777

United States (US):

- Help desk: <https://raymarine.custhelp.com/app/home>
- Tel: +1 (603) 324 7900 (Toll-free: +800 539 5539)

Australia and New Zealand (Raymarine subsidiary):

- E-Mail: aus.support@raymarine.com
- Tel: +61 2 8977 0300

France (Raymarine subsidiary):

- E-Mail: support.fr@raymarine.com
- Tel: +33 (0)1 46 49 72 30

Germany (Raymarine subsidiary):

- E-Mail: support.de@raymarine.com
- Tel: +49 40 237 808 0

Italy (Raymarine subsidiary):

- E-Mail: support.it@raymarine.com
- Tel: +39 02 9945 1001

Spain (Authorized Raymarine distributor):

- E-Mail: sat@azimut.es
- Tel: +34 96 2965 102

Netherlands (Raymarine subsidiary):

- E-Mail: support.nl@raymarine.com
- Tel: +31 (0)26 3614 905

Sweden (Raymarine subsidiary):

- E-Mail: support.se@raymarine.com
- Tel: +46 (0)317 633 670

Finland (Raymarine subsidiary):

- E-Mail: support.fi@raymarine.com
- Tel: +358 (0)207 619 937

Norway (Raymarine subsidiary):

- E-Mail: support.no@raymarine.com

- Tel: +47 692 64 600

Denmark (Raymarine subsidiary):

- E-Mail: support.dk@raymarine.com
- Tel: +45 437 164 64

Russia (Authorized Raymarine distributor):

- E-Mail: info@mikstmarine.ru
- Tel: +7 495 788 0508

14.3 Learning resources

Raymarine has produced a range of learning resources to help you get the most out of your products.

Video tutorials

Raymarine official channel on YouTube

- <http://www.youtube.com/user/RaymarineInc>

Training courses

Raymarine regularly runs a range of in-depth training courses to help you make the most of your products. Visit the Training section of the Raymarine website for more information:

- <http://www.raymarine.co.uk/view/?id=2372>

Technical support forum

You can use the Technical support forum to ask a technical question about a Raymarine product or to find out how other customers are using their Raymarine equipment. The resource is regularly updated with contributions from Raymarine customers and staff:

- <https://raymarine.custhelp.com/app/home>

CHAPTER 15: TECHNICAL SPECIFICATION

CHAPTER CONTENTS

- 15.1 Power specification — page 65
- 15.2 Environmental specification — page 65
- 15.3 AIS specification — page 65
- 15.4 GNSS receiver specification — page 65
- 15.5 External connections — page 65
- 15.6 VHF antenna requirements — page 66

15.1 Power specification

Specification	
Supply voltage:	12 V dc / 24 V dc
Operating voltage range:	9.6 V dc to 31.2 V dc
Peak current:	<ul style="list-style-type: none">• 2.5A @ 12 V dc• 1.25A @ 24 V dc
Typical power consumption:	3 Watts
Fuse rating:	3 A
LEN (Load Equivalency Number):	1

15.2 Environmental specification

Specification	
Operating temperature range:	-15°C to +55°C (+5°F to +131°F)
Storage temperature range:	-20°C to +75°C (-4°F to 167°F)
Humidity:	Up to 93% at 40°C
Waterproof rating:	IPx6, IPx7

15.3 AIS specification

Specification	
Transmitter:	x 1
Receiver:	x 2
Operating frequency range:	<ul style="list-style-type: none">• Transmitting: 156.0MHz to 162.025 MHz• Receiving: 156.0MHz to 174.0 MHz
Channel spacing:	25 KHz
AIS performance:	5 W SOTDMA

15.4 GNSS receiver specification

Specification	
Channels:	72
Cold start acquisition:	26s (nominal)
Position source:	<ul style="list-style-type: none">• GPS• GLONASS

15.5 External connections

Specification	
VHF antenna connector type:	SO-239 co-axial
VHF radio connector type:	SO-239 co-axial
GNSS antenna connector type:	50 ohm TNC co-axial
SeaTalk ng® / NMEA 2000 connector type:	5-way DeviceNet male
Power and NMEA 0183:	12-way bare-ended wires
NMEA 0183 port 1 (typically used for sending AIS data to an MFD):	NMEA 0183 HS (IEC 61162-1) compliant, bi-directional, RS422 levels, 4-wire interface (differential signalling), configurable baud rate
NMEA 0183 port 2 (typically used for receiving heading data from an external device, such as a Gyro compass):	NMEA 0183 (IEC 61162-1) compliant, bi-directional, RS422 levels, 4-wire interface (differential signalling), configurable baud rate
Power:	2-way bare-ended wires
Silent mode switch:	2-way bare-ended wires

Specification	
USB:	Micro-B
Earth stud (for grounding):	Threaded stud (nut and washer supplied)
Note:	
It is possible to configure the baud rate for each NMEA 0183 port in the ProAIS software. However, this feature is intended for diagnostic and troubleshooting purposes only . The ProAIS2 software can be downloaded from the Raymarine website: www.raymarine.com/software	

15.6 VHF antenna requirements

Important requirements related to the type and specification of the VHF antenna required for your AIS unit.

To ensure optimum antenna performance, adhere to the following guidelines:

- The use of a **wideband** VHF antenna is highly recommended, rather than an AIS-only antenna.
- The AIS700 requires a wideband antenna to provide good performance for both the AIS transceiver and a connected VHF radio utilizing the AIS700's integrated antenna splitter.
- Using a VHF antenna optimized for only AIS frequency operation may permanently damage the AIS700, as VHF radio transmissions are reflected back into the AIS700 due to the poor impedance match of the VHF antenna operating at VHF radio frequencies.
- Using a **non**-wideband VHF antenna optimized only for VHF radio frequencies may cause transmissions from the AIS transceiver to be reflected back into the AIS700, due to the poor impedance match of the antenna and AIS transceiver frequencies. Although this will not damage the AIS700 (because AIS class B transmissions are of substantially lower power than VHF transmissions), it could result in the AIS700 triggering a system VSWR alarm.
- New VHF antennas are sold with a fixed cable length. The cable length partly determines the antenna performance, and therefore cutting the cable of an antenna can affect its performance and result in a high VSWR ratio and limited reception.

Recommended VHF antenna specifications

Specifications	
Frequency band:	156.025 MHz to 162.025 MHz
VSWR (Voltage Standing Wave Ratio):	Should not exceed 2:1, across the entire frequency range
Impedance:	50 Ohm wideband
Gain:	3dBi Max
Connector type:	PL-259

CHAPTER 16: SPARES AND ACCESSORIES

CHAPTER CONTENTS

- 16.1 Spares and accessories — page 68
- 16.2 SeaTalkng[®] cables and accessories — page 68

16.1 Spares and accessories

The following spares are available:

Part number	Description
R62241	GNSS passive antenna with 10 m (32.8 ft) coaxial cable (for AIS transceivers only)
R32162	2 m (6.56 ft) Power/data cable

16.2 SeaTalkng® cables and accessories

SeaTalkng® cables and accessories for use with compatible products.

SeaTalkng® kits

SeaTalkng kits enable you to create a simple SeaTalkng backbone.

Starter kit (part number: T70134) consists of:

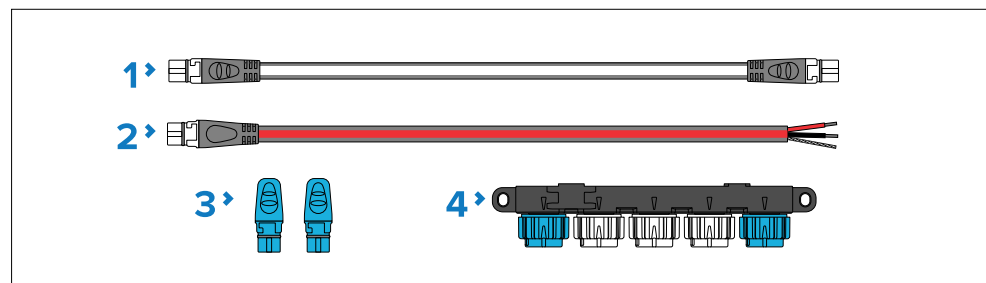

- 1 x Spur cable 3 m (9.8 ft) (part number: **A06040**). Used to connect device to the SeaTalkng backbone.
- 1 x Power cable 2 m (6.6 ft) (part number: **A06049**). Used to provide 12 V dc power to the SeaTalkng backbone.
- 2 x Backbone terminators (part number: **A06031**). Terminators must be fitted to both ends of the SeaTalkng backbone.
- 1 x 5-Way connector (part number: **A06064**). Each connector block allows connection of up to 3 SeaTalkng devices. Multiple connector blocks can be 'daisy chained' together.

Backbone kit (part number: A25062) consists of:

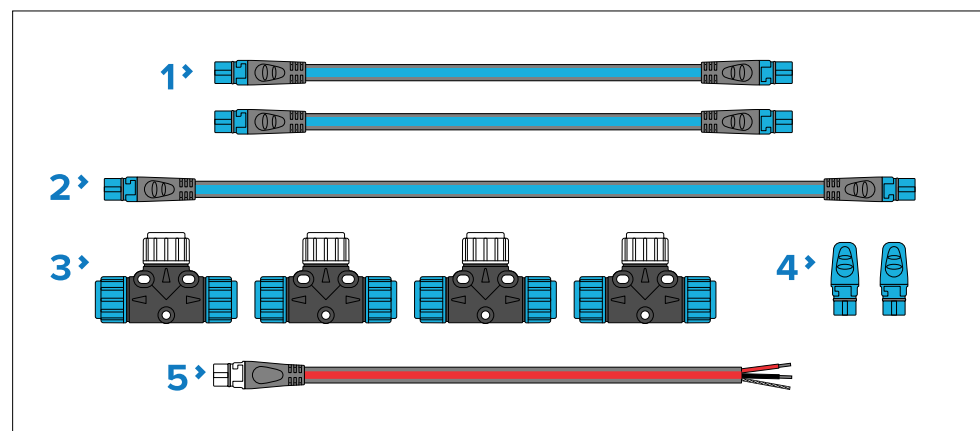

- 2 x Backbone cables 5 m (16.4 ft) (part number: **A06036**). Used to create and extend the SeaTalkng backbone.
- 1 x Backbone cable 20 m (65.6 ft) (part number: **A06037**). Used to create and extend the SeaTalkng backbone.
- 4 x T-piece (part number: **A06028**). Each T-piece allows connection of one SeaTalkng device. Multiple T-pieces can be 'daisy chained' together.
- 2 x Backbone terminators (part number: **A06031**). Terminators must be fitted to both ends of the SeaTalkng backbone.
- 1 x Power cable 2 m (6.6 ft) (part number: **A06049**). Used to provide 12 V dc power to the SeaTalkng backbone.

Evolution autopilot cable kit (part number: R70160) consists of:

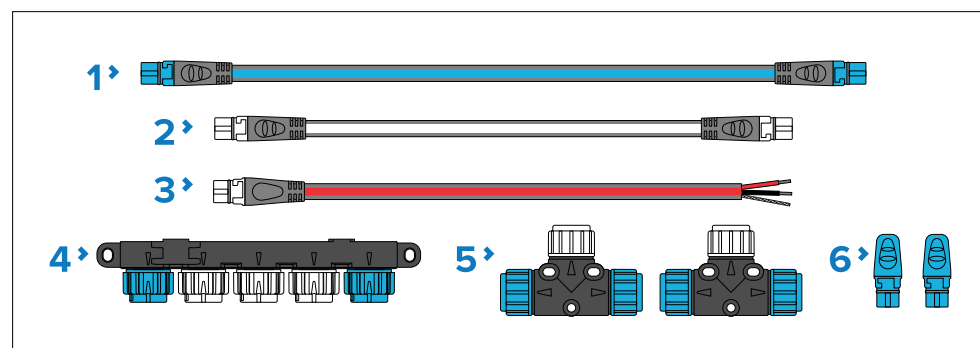

- 1 x Backbone cable 5 m (16.4 ft) (part number: **A06036**). Used to create and extend the SeaTalkng backbone.

- 1 x Spur cable 1 m (3.3 ft) (part number: **A06040**). Used to connect device to the SeaTalkng backbone.
- 1 x Power cable 2 m (6.6 ft) (part number: **A06049**). Used to provide 12 V dc power to the SeaTalkng backbone.
- 1 x 5-Way connector (part number: **A06064**). Each connector block allows connection of up to 3 SeaTalkng devices. Multiple connector blocks can be 'daisy chained' together.
- 2 x T-pieces (part number: **A06028**). Each T-piece allows connection of one SeaTalkng device. Multiple T-pieces can be 'daisy chained' together.
- 2 x Backbone terminators (part number: **A06031**). Terminators must be fitted to both ends of the SeaTalkng backbone.

SeaTalk to SeaTalkng converter kit (part number: E22158) consists of:

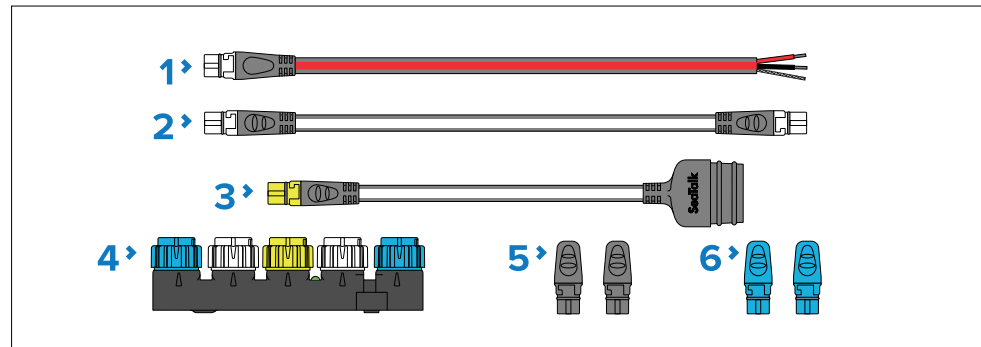

- 1 x Power cable 2 m (6.6 ft) (part number: **A06049**). Used to provide 12 V dc power to the SeaTalkng backbone.
- 1 x Spur cable 1 m (3.3 ft) (part number: **A06039**). Used to connect a device to the SeaTalkng backbone.
- 1 x SeaTalk (3 pin) to SeaTalkng adapter cable 0.4 m (1.3 ft) (part number: **A22164**). Used to connect SeaTalk devices to the SeaTalkng backbone via the SeaTalk to SeaTalkng converter.
- 1 x SeaTalk to SeaTalkng converter (part number: **E22158**). Each converter allows connection of one SeaTalk device and up to 2 SeaTalkng devices.
- 2 x Spur blanking plugs (part number: **A06032**). Used to cover unused spur connections in 5-way blocks, T-piece connectors and SeaTalk to SeaTalkng converter.
- 2 x Backbone terminators (part number: **A06031**). Terminators must be fitted to both ends of the SeaTalkng backbone.

NMEA 0183 VHF 2 wire to SeaTalkng converter kit (part number: E70196) consists of:

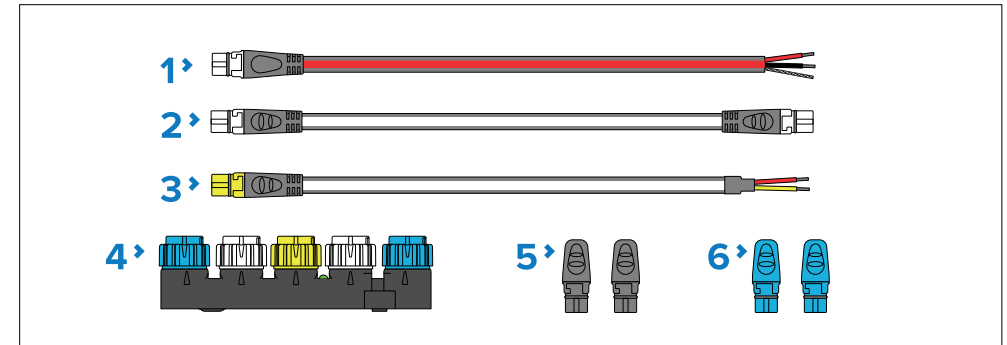

- 1 x Power cable 2 m (6.6 ft) (part number: **A06049**). Used to provide 12 V dc power to the SeaTalkng backbone.
- 1 x Spur cable 1 m (3.3 ft) (part number: **A06039**). Used to connect a device to the SeaTalkng backbone.
- 1 x NMEA 0183 VHF stripped-end (2 wire) to SeaTalkng adapter cable 1 m (3.3 ft) (part number: **A06071**). Used to connect an NMEA 0183 VHF radio to the SeaTalkng backbone via the NMEA 0183 VHF to SeaTalkng converter.
- 1 x SeaTalk to SeaTalkng converter (part number: **E22158**). Each converter allows connection of 1 SeaTalk device and up to 2 SeaTalkng devices.
- 2 x Spur blanking plugs (part number: **A06032**). Used to cover unused spur connections in 5-way blocks, T-piece connectors and SeaTalk to SeaTalkng converter.
- 2 x Backbone terminators (part number: **A06031**). Terminators must be fitted to both ends of the SeaTalkng backbone.

SeaTalkng® spur cables

SeaTalkng spur cables are required to connect devices to the SeaTalkng backbone.

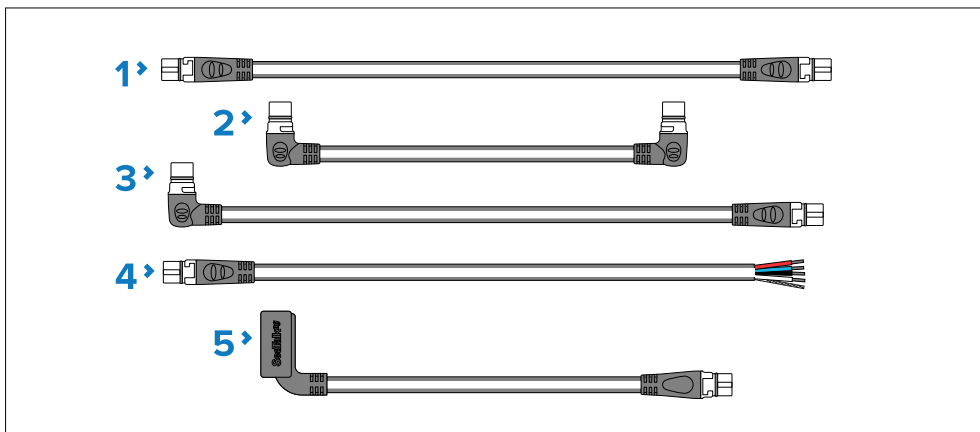

1. SeaTalkng spur cables:
 - Spur cable 0.4 m (1.3 ft) (part number: **A06038**).
 - Spur cable 1 m (3.3 ft)(part number: **A06039**).
 - Spur cable 3 m (9.8 ft) (part number: **A06040**).
 - Spur cable 5 m (16.4 ft) (part number: **A06041**).
2. Elbow (right angled) to elbow (right angled) spur cable 0.4 m (1.3 ft) (part number: **A06042**). Used in confined spaces where a straight spur cable will not fit.
3. Elbow (right angled) to straight spur cable 1 m (3.3 ft) (part number: **A06081**). Used in confined spaces where a straight spur cable will not fit.
4. SeaTalkng to stripped-end spur cables (Connects compatible product that do not have a SeaTalkng connector such as transducer pods):
 - SeaTalkng to stripped-end spur cable 1 m (3.3 ft) (part number: **A06043**)
 - SeaTalkng to stripped-end spur cable 3 m (9.8 ft) (part number: **A06044**)
5. ACU / SPX autopilot to SeaTalkng spur cable 0.3 m (1.0 ft) (part number **R12112**). Connects the course computer to the SeaTalkng backbone. This connection can also be used to provide 12 V dc power to the SeaTalkng backbone.

SeaTalkng® backbone cables

SeaTalkng backbone cables are used to create or extend a SeaTalkng backbone.



- Backbone cable 0.4 m (1.3 ft) (part number: **A06033**).
- Backbone cable 1 m (3.3 ft) (part number: **A06034**).
- Backbone cable 3 m (9.8 ft) (part number: **A06035**).
- Backbone cable 5 m (16.4 ft) (part number: **A06036**).
- Backbone cable 9 m (29.5 ft) (part number: **A06068**).
- Backbone cable 20 m (65.6 ft) (part number: **A06037**).

SeaTalkng® power cables

SeaTalkng power cables are used to provide the SeaTalkng backbone with a single 12 V dc power source. The power connection must include a 5 amp inline fuse (not supplied).

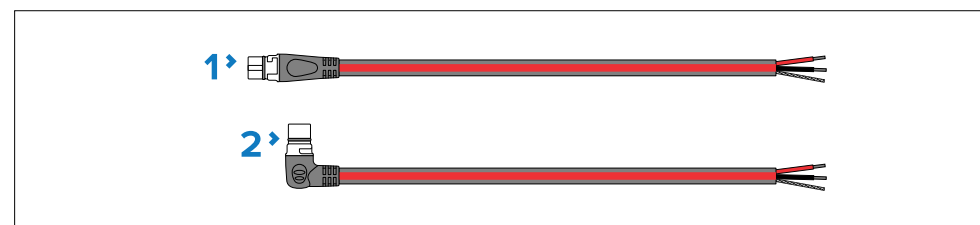

1. Power cable (straight) 2 m (6.6 ft) (part number: **A06049**).
2. Elbow (right angled) power cable 2 m (6.6 ft) (part number: **A06070**).

SeaTalkng® connectors

SeaTalkng connectors are used to connect SeaTalkng devices to the SeaTalkng backbone and to create and extend the backbone.

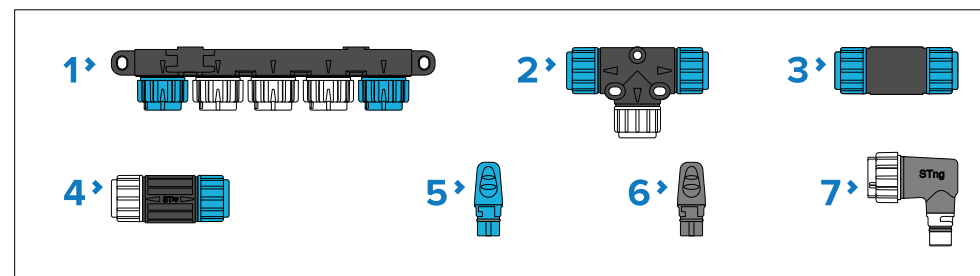

1. 5-Way connector (part number: **A06064**). Each connector block allows connection of up to 3 SeaTalkng devices. Multiple connector blocks can be 'daisy chained' together.
2. T-piece (part number: **A06028**). Each T-piece allows connection of one SeaTalkng device. Multiple T-pieces can be 'daisy chained' together.
3. Backbone extender (part number: **A06030**). Used to connect 2 backbone cables together.
4. Inline terminator (part number: **A80001**). Used to connect a spur cable and SeaTalkng device at the end of a backbone instead of a backbone terminator.
5. Backbone terminator (part number: **A06031**). Terminators must be fitted to both ends of the SeaTalkng backbone.
6. Spur blanking plug (part number: **A06032**). Used to cover unused spur connections in 5-way blocks, T-piece connectors, or the SeaTalk to SeaTalkng converter.
7. Elbow (right angled) spur connector (part number: **A06077**). Used in confined spaces where a straight spur cable will not fit.

SeaTalkng® adaptors and adaptor cables

SeaTalkng adaptor cables are used to connect devices designed for different CAN bus backbones (e.g.: SeaTalk or DeviceNet) to the SeaTalkng backbone.

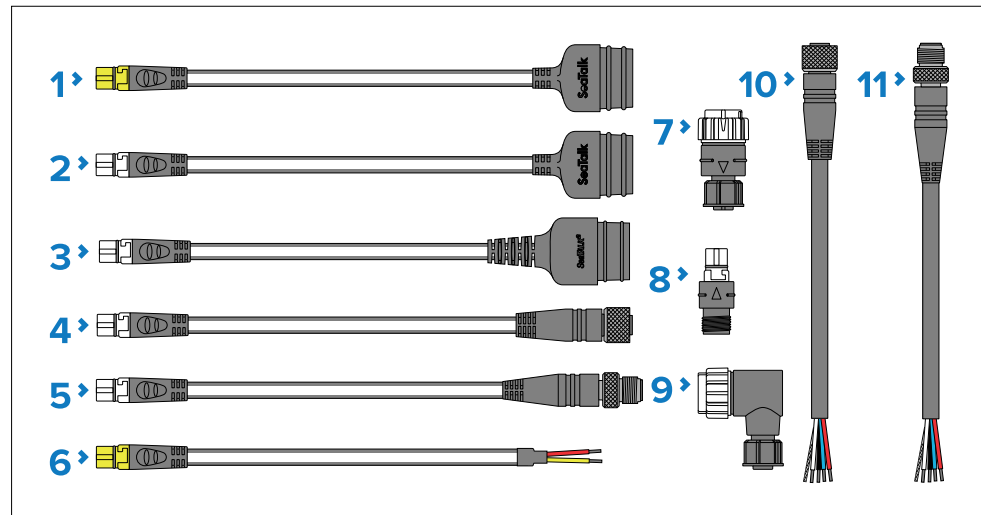

1. SeaTalk (3 pin) to SeaTalkng converter cable 1 m (3.3 ft) (part number: **A22164 / A06073**). Can be used to connect a SeaTalk device to a

SeaTalkng backbone via the SeaTalk to SeaTalkng converter, or to connect a SeaTalkng product directly to a SeaTalk network.

2. SeaTalk (3 pin) to SeaTalkng adaptor cable 0.4 m (1.3 ft) (part number: **A06047**). Can be used to connect a SeaTalk device to a SeaTalkng backbone via the SeaTalk to SeaTalkng converter, or to connect a SeaTalkng product directly to a SeaTalk network.
3. SeaTalk2 (5 pin) to SeaTalkng adaptor cable 0.4 m (1.3 ft) (part number: **A06048**). Used to connect SeaTalk2 devices or networks to a SeaTalkng backbone.
4. SeaTalkng to DeviceNet (female) adaptor cables connect NMEA 2000 devices that use a DeviceNet connector to the SeaTalkng backbone, or connects SeaTalkng devices to an NMEA 2000 network. The following cables are available:
 - SeaTalkng to DeviceNet (female) adaptor cable 0.4 m (1.3 ft) (part number: **A06045**).
 - SeaTalkng to DeviceNet (female) adaptor cable 1 m (3.3 ft) (part number: **A06075**).
5. SeaTalkng to DeviceNet (male) adaptor cables. Connect NMEA 2000 devices that use a DeviceNet connector to the SeaTalkng backbone, or connect SeaTalkng devices to an NMEA 2000 network. The following cables are available:
 - SeaTalkng to DeviceNet (male) adaptor cable 0.1 m (0.33 ft) (part number: **A06078**).
 - SeaTalkng to DeviceNet (male) adaptor cable 0.4 m (1.3 ft) (part number: **A06074**).
 - SeaTalkng to DeviceNet (male) adaptor cable 1 m (3.3 ft) (part number: **A06076**).
 - SeaTalkng to DeviceNet (male) adaptor cable 1.5 m (4.92 ft) (part number: **A06046**).
6. NMEA 0183 VHF stripped-end (2 wire) to SeaTalkng adapter cable 1 m (3.3 ft) (part number: **A06071**). Used to connect an NMEA 0183 VHF radio to the SeaTalkng backbone via the NMEA 0183 VHF to SeaTalkng converter.
7. SeaTalkng (male) to DeviceNet (female) adaptor (**A06082**).
8. SeaTalkng (female) to DeviceNet (male) adaptor (**A06083**).
9. SeaTalkng (male) to DeviceNet (female) elbow (right angled) adaptor (**A06084**).

10. DeviceNet (female) to stripped-end adaptor cable (0.4 m (1.3 ft) (part number: **E05026**).
11. DeviceNet (male) to stripped-end adaptor cable (0.4 m (1.3 ft) (part number: **E05027**).

Appendix A Licensing and MMSI issuing authorities

The following table lists the relevant issuing authority for licences and MMSI numbers in each region, along with a link to the relevant website. Many authorities allow you to apply for a license online.

Country & regulatory authority	Website
<u>Argentina (AR):</u> Ente Nacional de Comunicaciones	http://www.enacom.gov.ar
<u>Australia (AU):</u> Australian Communications and Media Authority	http://www.acma.gov.au/
<u>Austria (AT):</u> Austrian Regulatory Authority for Broadcasting and Telecommunications	http://www.rtr.at
<u>Belgium (BE):</u> Belgian Institute for Postal services and Telecommunications (BIPT)	http://www.bipt.be
<u>Brazil (BR):</u> Agencia Nacional de Telecomunicacoes	http://www.anatel.gov.br
<u>Bulgaria (BG):</u> Communications Regulation Commission	http://www.crc.bg
<u>Canada (CA):</u> Industry Canada	https://www.ic.gc.ca/eic/site/smt-gst.nsf/eng/home
<u>China (ZH):</u> Ministry of Information Industry	http://www.mii.gov.cn
<u>Costa Rica (CR):</u> Superintendencia de Telecomunicaciones	http://sutel.go.cr

Country & regulatory authority	Website
<u>Croatia (HR):</u> Croatian Post and Electronic Communications Agency	http://www.hakom.hr/default.aspx?id=7
<u>Cyprus (CY):</u> Office of Electronic Communications & Postal Regulation	http://www.ocecpr.org.cy/nqcontent.cfm?a_id=767&tt=ocecpr&lang=gr
<u>Czech Republic (CZ):</u> The Czech Telecommunication Office	http://www.ctu.eu/main.php?pageid=178
<u>Denmark (DK):</u> Danish Energy Agency	https://ens.dk/en
<u>Estonia (EE):</u> Estonian Competition Authority	http://www.konkurentsiamet.ee/?lang=en
<u>Finland (FI):</u> Finnish Communications Regulatory Authority	http://www.ficora.fi/en
<u>France (FR):</u> Autorité de Régulation des Communications Électroniques et des Postes	http://www.arcep.fr
<u>Germany (DE):</u> Bundesnetzagentur	http://www.bundesnetzagentur.de
<u>Greece (EL):</u> Hellenic Telecommunications and Post Commission	http://www.eett.gr/opencms/opencms/EETT_EN/index.html
<u>Holland (NL):</u> Autoriteit Consument & Markt	https://www.acm.nl/nl
<u>Hong Kong (HK):</u> Office of Communications Authority	http://www.ofca.gov.hk

Country & regulatory authority	Website
<u>Hungary (HU):</u> National Media and Infocommunication Authority	http://www.nmhh.hu
<u>Iceland (IS):</u> Post and Telecom Administration	http://www.pfs.is/default.aspx?cat_id=101
<u>Indonesia (ID):</u> Indonesian Telecommunications Regulatory Authority	http://www.brti.or.id
<u>Ireland (IE):</u> Commission for Communications Regulation	http://www.comreg.ie
<u>Isle of Man (IM):</u> Communications Commission	http://www.gov.im/government/boards/cc.xml
<u>Italy (IT):</u> Autorità per le Garanzie nelle Comunicazioni	http://www.agcom.it
<u>Jamaica (JM):</u> Spectrum Management Authority	http://www.sma.gov.jm
<u>Japan (JP):</u> Ministry of Internal Affairs and Communications	http://www.soumu.go.jp/english/index.html
<u>Korea, South (KR):</u> Korea Communications Commission	http://eng.kcc.go.kr
<u>Lichtenstein (LI):</u> Office for Communications	http://www.llv.li/amtsstellen/llv-ak-english-page.htm
<u>Lithuania (LT):</u> Communications Regulatory Authority	http://www.rtt.lt/en/home.html

Country & regulatory authority	Website
<u>Luxembourg (LU):</u> Institut luxembourgeois de régulation	http://www.ilr.public.lu
<u>Latvia (LV):</u> Elektronisko sakaru direkcija	https://www.vases.lv/lv/content/juras-sakaru-atlaujas
<u>Malaysia (MY):</u> Malaysian Communications and Multimedia Commission	http://www.mcmc.gov.my
<u>Malta (MT):</u> Malta Communications Authority	http://www.mca.org.mt
<u>Mexico (MX):</u> Instituto Federal de Telecomunicaciones	http://www.ift.org.mx
<u>New Zealand (NZ):</u> Commerce Commission of New Zealand	http://www.comcom.govt.nz
<u>Norway (NO):</u> Norwegian Communications Authority	http://www.nkom.no
<u>Panama (PA):</u> Autoridad Nacional de los Servicios Públicos	http://www.asep.gob.pa/default.asp
<u>Poland (PL):</u> Prezes Urzędu Komunikacji Elektronicznej	http://www.uke.gov.pl
<u>Portugal (PT):</u> Autoridade Nacional de Comunicações	https://www.anacom.pt

Country & regulatory authority	Website
<u>Romania (RO):</u> National Authority for Management and Regulation in Communications of Romania	http://www.ancom.org.ro/en
<u>Russia (RU):</u> Ministry of Telecom and Mass Communications of the Russian Federation	https://minsvyaz.ru/en
<u>Saudi Arabia (SA):</u> Communications and Information Technology Commission (Saudi Arabia)	http://www.citc.gov.sa
<u>Singapore (SG):</u> Info-communications Media Development Authority of Singapore	https://www.imda.gov.sg
<u>Slovenia (SI):</u> Agency for communication networks and services of the Republic of Slovenia	http://www.akos-rs.si/akos-ang
<u>Slovakia (SK):</u> Telecommunications Regulatory Authority of the Slovak Republic	http://www.teleoff.gov.sk/index.php?ID=9
<u>South Africa (ZA):</u> Independent Communications Authority of South Africa	http://www.icasa.org.za
<u>Spain (ES):</u> Comisión Nacional de los Mercados y la Competencia	https://www.cnmc.es/en
<u>Sweden (SE):</u> Swedish Post and Telecom Authority	http://www.pts.se

Country & regulatory authority	Website
<u>Switzerland (CH):</u> Office fédéral de la communication	http://www.bakom.admin.ch/themen/frequenzen/00689/01563/index.html?lang=fr
<u>Taiwan (TW):</u> National Communications Commission	http://www.ncc.gov.tw/english/index.aspx
<u>Thailand (TH):</u> National Broadcasting and Telecommunications Commission	http://nbt.go.th/wps/portal/NTC/eng
<u>Turkey (TR):</u> Information And Communication Technologies Authority	http://eng.btk.gov.tr
<u>United Arab Emirates (AE):</u> Telecommunications Regulatory Authority	http://www.tra.ae
<u>United Kingdom and Northern Ireland (UK (NI)):</u> OFCOM	http://www.ofcom.org.uk
<u>United States (US):</u> FCC	https://www.fcc.gov/bureau-divisions/mobility-division/ship-radio-stations#block-menu-block-4

Appendix B NMEA 0183 supported sentences

The AIS700 supports the following NMEA 0183 sentences

Sentence	Description
ABK	ABM/BBM acknowledgement (Transmit)
ABM	Addressed binary message (Receive)
ACA	AIS channel management assignment (Transmit)
ACS	AIS channel management information source (Transmit)
AIQ	AIS query (Receive)
ACK	Acknowledge alarm (Receive)
BBM	Broadcast binary message (Receive)
HDT	Heading true (Receive)
RST	Equipment reset command (Transmit / Receive)
SSD	Ship static data (Receive)
THS	True heading and status (Receive)
TXT	Text (Transmit)
VDM	AIS VHF data-link message (Transmit)
VDO	AIS VHF data-link own-vessel report (Transmit)
VSD	Voyage static data (Receive)

Sentences output by query (AIQ):

Sentence	Description
ACA	AIS channel management assignment
SSD	Ship static data
TXT	Text
VER	Version
VSD	Voyage static data

Appendix C NMEA 2000 supported PGNs

The AIS700 supports the following PGNs.

PGN	Description
59392	ISO Acknowledgement (Transmit / Receive)
59904	ISO Request (Transmit / Receive)
60928	ISO Address Claim (Transmit / Receive)
65240	ISO Commanded Address (Transmit / Receive)
126208	Request group function (Transmit / Receive)
126992	System time (Transmit)
126993	Heartbeat (Transmit)
126996	Product information (Transmit / Receive)
127250	Vessel heading (Receive)
129025	Position, rapid update (Transmit)
129026	COG & SOG, rapid update (Transmit)
129029	GNSS position data (Transmit)
129038	AIS Class A position report (Transmit)
129039	AIS Class B position report (Transmit)
129040	AIS Class B extended position report (Transmit)
129041	AIS AToN report (Transmit)
129793	AIS UTC and date report (Transmit)
129794	AIS class A static and voyage related data (Transmit)
129795	AIS addressed binary message (Transmit)
129796	AIS Acknowledge (Transmit)
129797	AIS binary broadcast message (Transmit)
129798	AIS SAR aircraft position report (Transmit)
129801	AIS addressed SRM (Transmit)
129802	AIS safety broadcast binary message (Transmit)

PGN	Description
129809	AIS class B CS static data report part A (Transmit)
129810	AIS class B CS static data report part B (Transmit)

Appendix D AIS limitation

Never assume that your AIS is detecting all vessels in the area. Always exercise due prudence and do not use AIS as a substitute for sound navigational judgement.

Appendix E Classes of AIS

Class A transceivers

Class A AIS transceivers transmit and receive AIS signals. AIS transceivers are currently mandatory on all commercial vessels exceeding 300 tons that travel internationally (SOLAS vessels).

The following information can be transmitted by a Class A AIS system:

- Static data (Includes information such as MMSI number, vessel name, vessel type, call sign, IMO number, length, beam and GNSS antenna location).
- Voyage related data (Includes information such as draft, cargo, destination, ETA and other relevant information).
- Dynamic data (Includes information such as time (UTC), ship's position, COG, SOG, heading, rate of turn and navigational status).
- Dynamic reports (Ship's speed and status).
- Messages (Alarms and safety messages).

Remember that not all vessels will transmit all of the information.

Class B transceivers

Class B AIS transceivers transmit and receive AIS signals, but use a reduced set of data compared to Class A (see *Data Summary*). A Class B AIS transceiver can be fitted on any vessel not fitted with a Class A transceiver, but is not mandatory aboard any vessel.

Appendix F Data Summary

Data	Receiver (receive)	Transceiver (transmit)	Transceiver (receive)
Ship's name	Yes	Yes	Yes
Type	Yes	Yes	Yes
Call sign	Yes	Yes	Yes
IMO number	Yes	No	Yes
Length and beam	Yes	Yes	Yes
Antenna location	Yes	Yes	Yes
Draft	Yes	No	Yes
Cargo Information	Yes	Yes	Yes
Destination	Yes	No	Yes
ETA	Yes	No	Yes
Time	Yes	Yes	Yes
Ship's position	Yes	Yes	Yes
COG	Yes	Yes	Yes
SOG	Yes	Yes	Yes
Gyro heading	Yes	Yes*	Yes
Rate of turn	Yes	No	Yes
Navigational status	Yes	No	Yes
Safety message	Yes	No	Yes

Note:

*Class B transceivers do not transmit a Gyro heading unless the transceiver is receiving an NMEA HDT sentence from an external source.

Data reporting intervals

AIS information is classed as either static or dynamic. Static information is broadcast, when data has been amended, or upon request, or by default, every 6 minutes.

The reporting rates for dynamic information depend on speed and course change, and are given in the following tables.

Note:

The reporting rates shown here are for reference and may not be the rate at which information is actually received by your AIS transceiver. This is dependent on a number of factors, including but not limited to antenna height, gain and signal interference.

Class A systems:

Ship's Dynamic Conditions	Reporting rate
At anchor or moored, moving less than 3 knots	<ul style="list-style-type: none"> • Not changing course: 3 minutes • Changing course: 3 minutes
At anchor or moored, moving greater than 3 knots	<ul style="list-style-type: none"> • Not changing course: 10 seconds • Changing course: 10 seconds
0-14 knots	<ul style="list-style-type: none"> • Not changing course: 10 seconds • Changing course: 3 1/3 seconds
14-23 knots	<ul style="list-style-type: none"> • Not changing course: 6 seconds • Changing course: 2 Seconds
Faster than 23 knots	<ul style="list-style-type: none"> • Not changing course: 2 seconds • Changing course: 2 seconds

Class B systems:

Ship's Dynamic Conditions	Reporting rate (nominal)
SOTDMA – 0 to 2 knots	3 Minutes
SOTDMA – 2 to 14 knots	30 Seconds
SOTDMA – 14 to 23 knots	15 Seconds
SOTDMA – Greater than 23 knots	5 Seconds

Ship's Dynamic Conditions	Reporting rate (nominal)
CSTDMA – 0 to 2 knots	3 Minutes
CSTDMA – Greater than 2 knots	30 Seconds

Other AIS sources:

Source	Reporting rate
Search and Rescue (SAR) aircraft	10 Seconds
Aids to Navigation (AToN)	3 Minutes
AIS base station	10 Seconds or 3.33 Seconds, depending on operating parameters

Index

A

Accessories	
SeaTalkng adaptor cables	71
SeaTalkng backbone cables	70
SeaTalkng cables	68
SeaTalkng connectors	70
SeaTalkng kits	68
SeaTalkng Power cables	70
SeaTalkng spur cables	69
AIS	
Overview.....	15
AIS data	
Viewing on a display.....	52
Applicable products	13

B

Box contents, See Parts supplied

C

Cable	
Protection	28
Strain relief.....	28
Cabling	
Circuit isolation	28
Circuit isolation.....	28
Cleaning	55
Compass safe distance	26
Compatible instrument displays	17
Compatible legacy MFDs	17
Compatible MFDs.....	17
Compatible multifunction displays.....	16
Configuration.....	51
Connecting cables.....	28
Connection	
Antenna	29
Earth stud.....	44
GNSS	29

GNSS antenna	38
GPS antenna	38
Ground.....	29
Grounding.....	44
Inputs / Outputs	34, 37
NMEA.....	29
NMEA 0183	34, 37
NMEA 2000	34
Overview.....	29
Power.....	29, 42
proAIS2.....	36
SeaTalkng	34
Silent Mode.....	29
Silent mode switch.....	40
USB.....	29, 34, 36, 59
VHF	29
VHF antenna.....	39
VHF Radio.....	40
Connections	
Battery	43
DeviceNet.....	36
Distribution panel.....	43
General cabling guidance.....	28
NMEA 0183	34, 37
NMEA 2000	36
Power.....	42
SeaTalkng	36
Contact details.....	62
CSTDMA.....	15, 79

D

Diagnostics.....	59
Documentation.....	13

E

Electromagnetic Compatibility.....	25
EMC	25

F

Fuse rating.....	20, 42
Fuse requirement	20

G

Grounding	44
-----------------	----

I

Installation	
Best practice.....	44
EMC guidelines.....	25
Mounting.....	31
Interference	
Compass.....	26
RF.....	26

L

LED Status	59
Licensing	
Issuing authorities.....	47, 73
Requirement	10, 47
LightHouse 2.....	13
LightHouse™ 2	17
LightHouse 3.....	13
LightHouse 4.....	13
Location requirements	
General	25
GNSS antenna	25

M

Maintenance.....	9, 55
MMSI.....	10, 47
Issuing authorities.....	47, 73
Mounting	31

N

NMEA 0183	
-----------	--

Baud rate	34, 37
Multiplexed	34, 37
Ports.....	34, 37
wire colors	37

P

Parts supplied.....	20
Power	
Battery connection.....	43
Cable extension.....	44
Distribution	42
Distribution panel.....	43
Fuses	20
Sharing a breaker	43
Power cable extension	44
Power supply.....	42
proAIS2	51
Product recycling (WEEE)	11
Product returns process	61
Product support.....	62

R

Radio Frequency (RF) interference.....	26
Routine checks.....	55

S

SeaTalkng	
Adaptor cables	71
Backbone cables	70
Connectors	70
Kits	68
Power cables	70
Spur cables	69
SeaTalkng cables.....	68
Service Center.....	62
Servicing.....	9
SOTDMA.....	15, 79
Support forum	63

T

Technical specification.....	64
AIS specification	65
Environmental specification.....	65
External connections	65
GNSS receiver specification	65
Power specification.....	65
Technical support.....	62–63
Thermal breaker rating.....	20, 42
Training courses.....	63
Troubleshooting	57
AIS data	57
Power.....	57
USB.....	59

V

Ventilation	25
-------------------	----

W

Warranty	11, 61–62
WEEE Directive.....	11



Raymarine (UK / EU)

Marine House, Cartwright Drive,
Fareham, Hampshire.
PO15 5RJ.
United Kingdom.

Tel: (+44) (0)1329 246 700

www.raymarine.co.uk

Raymarine (US)

110 Lowell Road,
Hudson, NH 03051.
United States of America.

Tel: (+1) 603-324-7900

www.raymarine.com



Raymarine®