

## Thermal camera JCU Installation instructions



### Warning: Product installation and operation

This product must be installed and operated in accordance with the instructions provided. Failure to do so could result in personal injury, damage to your boat and/or poor product performance.

### Caution: Service and maintenance

This product contains no user serviceable components. Please refer all maintenance and repair to authorized Raymarine dealers. Unauthorized repair may affect your warranty.

## Tools required

JCU installation requires the following tools:

- Jigsaw power drill.
- Power drill.
- 6.4 mm (0.25 in) drill bit.
- Screwdriver.

## Parts supplied

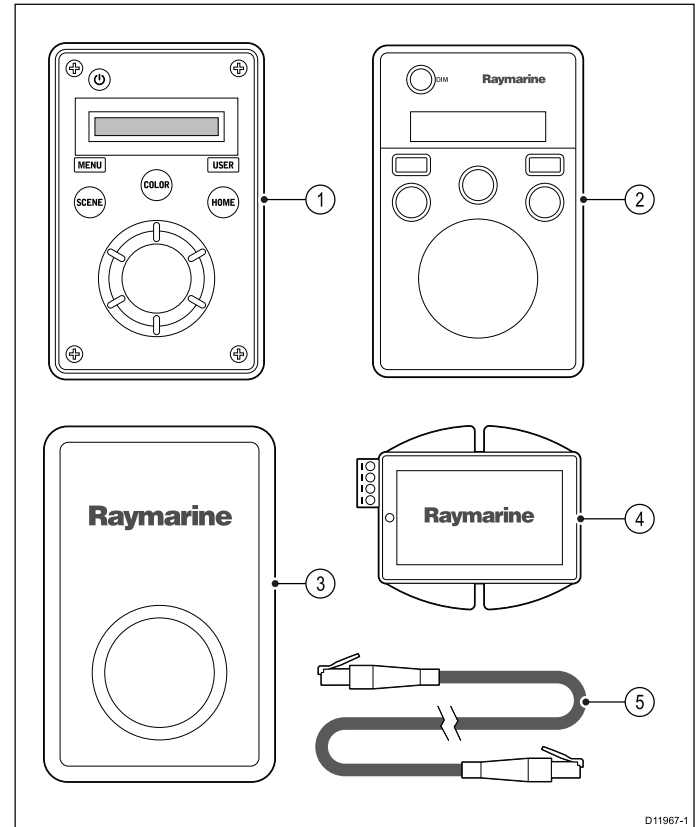

1. Joystick Control Unit (JCU).
2. Bezel.

3. Sun cover.
4. Power over Ethernet (PoE) injector.
5. Ethernet cable.

## Location requirements

When planning the installation location, consider the following points:

- Select a position on your vessel that is close to the monitor that displays the T-Series camera video output.
- Ensure the JCU is mounted at least 55 cm (21.7") away from any equipment fitted with a magnetic compass.
- The JCU can be mounted to a dash or other surface in any orientation.
- Consider cable lengths and cable routing.

## Flush mounting

The standard method for mounting the JCU is a flush or panel mounting arrangement.

Before mounting the unit, ensure that you have:

- Selected a suitable location. A clear, flat area with suitable clearance behind the panel is required.
- Identified the cable connection required and the route that the cable will take.
- Detached the front bezel to reveal the mounting screws.

## Mounting the JCU

1. Cut the mounting hole according to the dimensions specified in the mounting template included in this document.
2. Ensure that the unit fits into the removed area and then file around the cut edge until smooth.
3. Drill four 6.4 mm (0.25 in) holes as indicated on the template to accept the mounting screws.
4. Before mounting the JCU, insert the supplied ethernet cable through the mounting hole and into the JCU ethernet port. Ensure the cable gland sealing nut is tightened correctly.
5. Remove the 4 panel mounting clamps and insert the JCU in place. Affix the mounting clamps to the screws on the other side of the mounting surface, ensuring that the mounting clamps are rotated outward from the JCU housing. Tighten the screws to draw the mounting clamps up against the mounting surface and then tighten another 1/4 to 1/2 turn. Do not overtighten the screws.
  - i. As shipped from the factory, the JCU can be mounted to a panel thickness ranging from 0.79 to 4.45 cm (0.31 to 1.750 in). The clamps are set with the small "foot" on the clamp facing towards the mounting surface, away from the front of the JCU, as shown in the "Thick panel mounting" diagram in this document.
  - ii. To mount the JCU to a panel thickness of 0.79 cm (0.31 in) or less, remove the clamps from the mounting screws, turn them around and thread them back onto each of the four screws. In this configuration, the clamp "foot" faces away from the mounting surface and allows the clamp to contact thinner panel surfaces while still allowing for proper compression of the JCU mounting gasket to form a watertight seal. This mounting configuration is shown in the "Thin panel mounting" diagram in this document.
6. Once you have secured the JCU in place, replace the bezel.

## Thin panel mounting

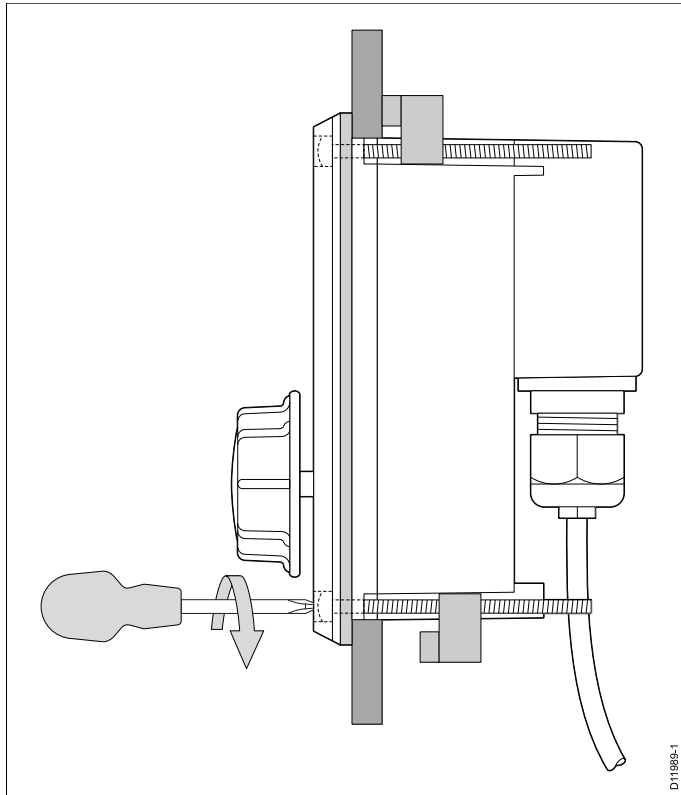

## Thick panel mounting

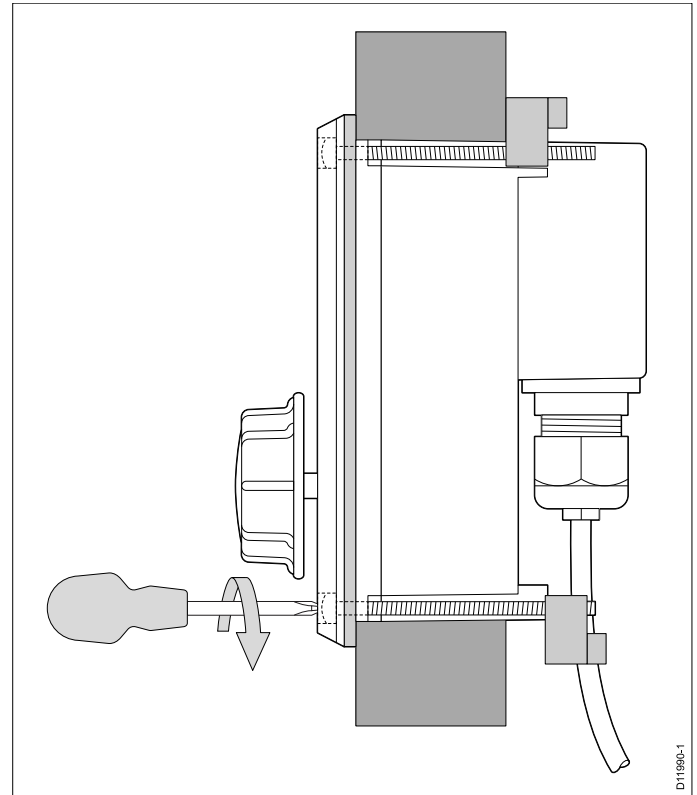

# T-Series JCU mounting template

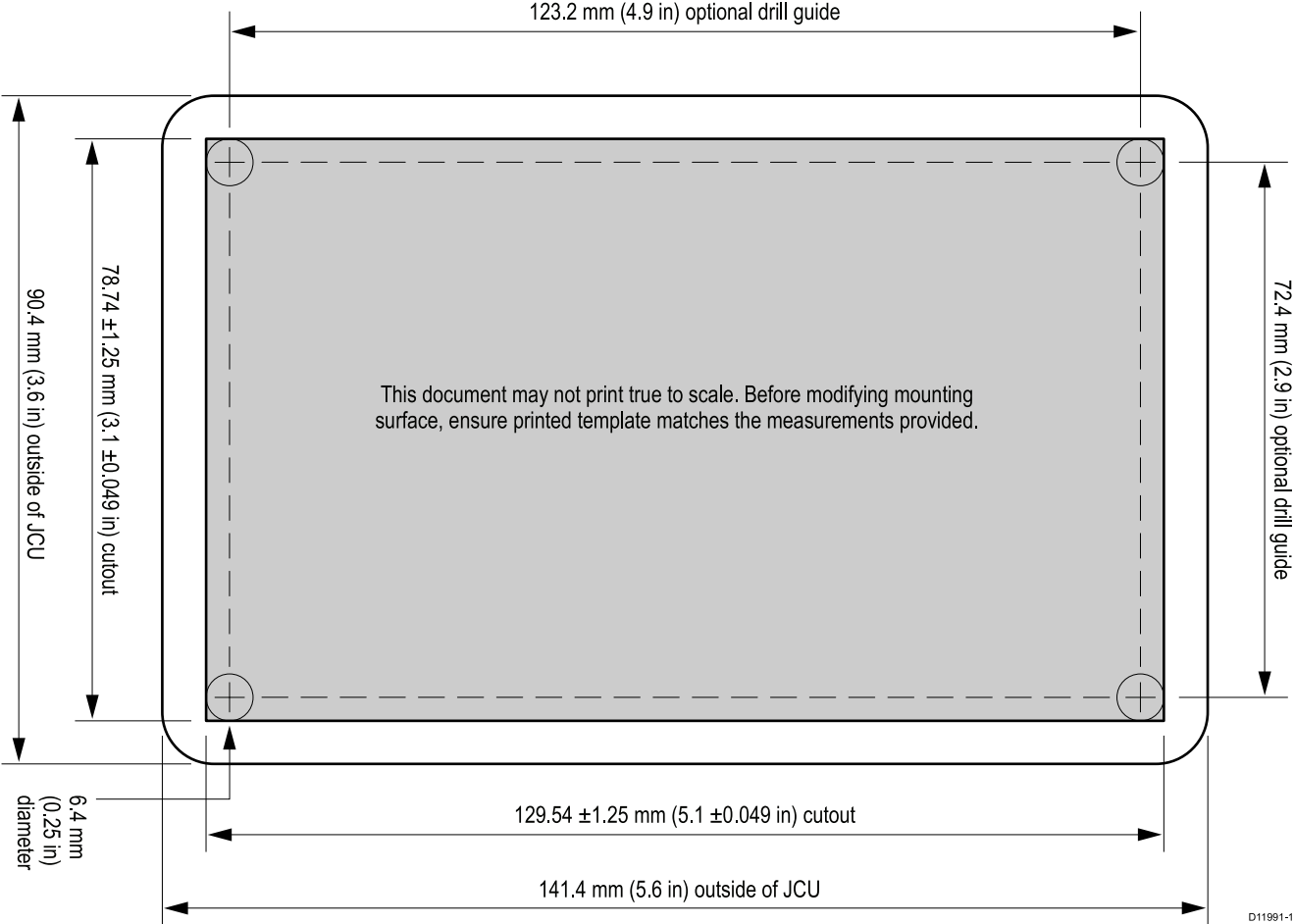

D11991-1

# Raymarine customer support

You can obtain this product information using the menus within your product.

Raymarine provides a comprehensive customer support service. You can contact customer support through the Raymarine website, telephone and email. If you are unable to resolve a problem, please use any of these facilities to obtain additional help.

## Web support

Please visit the customer support area of our website at:

[www.raymarine.com](http://www.raymarine.com)

This contains Frequently Asked Questions, servicing information, e-mail access to the Raymarine Technical Support Department and details of worldwide Raymarine agents.

## Telephone and email support

### In the USA:

- **Tel:** +1 603 881 5200 extension 2444
- **Email:** [Raymarine@custhelp.com](mailto:Raymarine@custhelp.com)

### In the UK, Europe, the Middle East, or Far East:

- **Tel:** +44 (0)23 9271 4713
- **Email:** [ukproduct.support@raymarine.com](mailto:ukproduct.support@raymarine.com)

## Product information

If you need to request service, please have the following information to hand:

- Product name.
- Product identity.
- Serial number.
- Software application version.



[www.raymarine.com](http://www.raymarine.com)



Thermal camera JCU Installation instructions