



INSTALLATION & OPERATION MANUAL

## ***DISCOVER D3***

---



# Preface

READ AND FOLLOW ALL INSTRUCTIONS IN THIS MANUAL



## CAUTION

(Risk Group 2): Possibly hazardous optical radiation emitted from this product. Do not stare at operating lamp. May be harmful to the eye.



## WARNINGS

Before installing your OceanLED Light, read and follow all warning notices and instructions which are included. Failure to follow safety warnings and instructions can result in property damage, severe injury or even death.

Before installing your OceanLED Light, check local laws for restrictions regarding the use of coloured lights in your area.

Salt is an inherently corrosive material. Metal parts and certain natural and man-made surfaces are particularly susceptible to corrosion and deterioration when used in and around salt water. Some OceanLED lights contain combinations of plastic and polymer products which are impervious to saltwater corrosion, however, screws and fasteners used for the installation must be of a marine grade type stainless steel or equivalent and monitored annually to ensure the lights remain in service for years to come.

Discover D3 light is for mounting directly to a flat surface. Do not submerge your cable ends in water; cable and connections exposed to underwater submersion will not be covered by warranty.

Never connect/disconnect lights with power applied as irreversible damage may occur. Ensure polarity of power connections is correct. Failure to do this may invalidate warranty.

Though the Discover D3 has protection against temporary submersion, please ensure the rear of the light is in a dry area and not subject to a wet environment, especially when installed. Failure to do this may invalidate warranty.

Never Use Solvents! Cleaners, fuel, and other products that may contain strong solvents, such as acetone, that attack many plastics greatly reducing their strength and irreversibly damaging the special lens coatings and cable sheathings.

Never clean lights using a high-pressure jet wash – this will invalidate warranty. Please avoid coating the front of the light/lens without consulting OceanLED. Failure to do so will invalidate your warranty.



## DANGER

### RISK OF ELECTRIC SHOCK OR ELECTROCUTION

This underwater light must be installed by a licensed or certified electrician in accordance with all applicable local codes and ordinances. Improper installation will create an electrical hazard which could result in death or serious injury to swimmers, installers, or others due to electrical shock, and may also cause damage to property. Always disconnect the power to the light at the circuit breaker before servicing the light.

# Contents

Preface .....	1
1 Installation Checklist.....	3
2 Overview.....	4
3 Preparing the Hull.....	5
4 Installation.....	6
4.1 INSTALLING THE LIGHT FIXTURE.....	6
4.2 ELECTRICAL INSTALLATION (12/24V DC).....	9
4.3 FINALISING THE INSTALLATION .....	11
4.4 TEST YOUR INSTALLATION.....	11
5 Operation / Maintenance.....	12
5.1 OPERATION .....	12
5.2 MAINTENANCE .....	12
6 Troubleshooting.....	13
6.1 TROUBLESHOOTING PROBLEMS AND THEIR SOLUTIONS .....	13
7 Appendix.....	15
7.1 OVERALL DIMENSIONS.....	15
7.2 DRILLING TEMPLATE.....	15
7.3 CABLE GAUGE CHART 12V .....	16
7.4 CABLE GAUGE CHART 24V .....	17
8 Warranty.....	19

## **PRETEST**

Always test the lights prior to installation. Failure to do this may result in additional installation time and could invalidate the warranty.

## **IMPORTANT NOTICE**

Attention Installer: This manual contains important information about the installation, operation, and safe use of this product. This information should be given to the owner and/ or operator of this equipment.

## **WARRANTY COVERAGE**

Please refer to [www.oceanled.com/downloads](http://www.oceanled.com/downloads) for full warranty statement.

# 1 Installation Checklist

1.  Decide on light spacing – OceanLED recommendations available.  
Though the Discover D3 has protection against temporary submersion from inside the boat, please ensure the rear of the light is in a dry area and not subject to a wet environment, when installed.
2.  Ensure correct cable gauge is used (refer to relevant cable gauge chart).
3.  Preparing the hull. Ensure hull thickness is below the maximum 50mm (2”).
4.  Make sure the lights have been fitted following the correct orientation.
5.  Correct marine sealant applied evenly around bezel.  
Ensure fully watertight seal is created after sealant cures.
6.  Correct fitting of light fixture onto hull. Never leave vessel unchecked for a few days after install.  
Always check routinely for a few days after installation to ensure the install is correct and fully sealed.
7.  Test installation BEFORE entering water. Never connect/ disconnect lights whilst powered ON.
8.  Troubleshooting if required - most issues can be resolved by following the guidelines.

# 2 Overview

## Identifying your model



Discover D3 Ultra White



Discover D3 Midnight Blue

### Product Overview

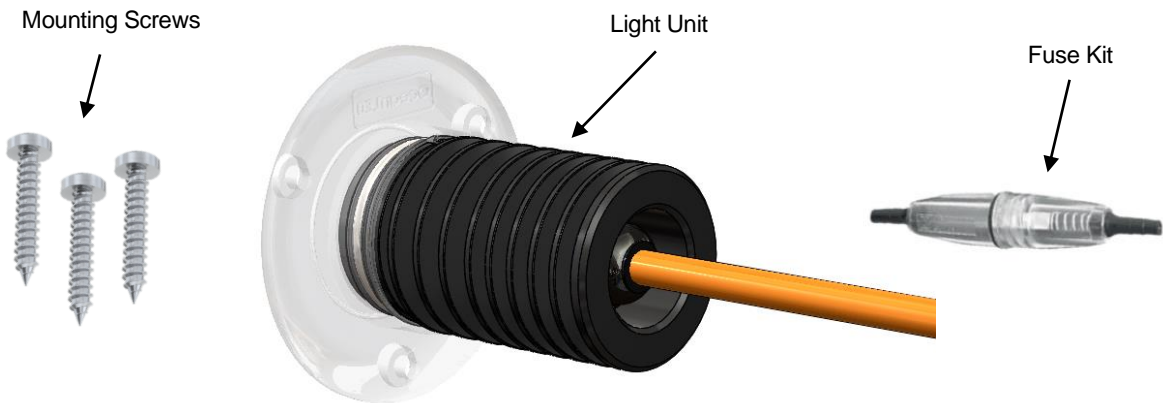

### Power Source

Most installations will utilise on-board 12/24V DC power supply from a marine battery. However, if AC to DC power supply is being used, please allow at least 15% reserve for voltage fluctuations due to variables beyond your control such as ambient temperature and supply voltage fluctuations. This is to ensure your lights are always receiving the proper voltage and to ensure the power supply is not “overloaded”, causing premature failure. Use chart below in determining power supplies.

### Power Consumption and Recommended Fuse values

Model	Current @ 12V DC	Current @ 24V DC	Max Nominal Power consumption	15% reserve in Watts	Recommended fuse 12V/24V DC
Discovery D3	0.7A	0.37A	9W	10.3W	1.25A

# 3 Preparing the Hull

 The Discover D3 unit requires an additional 60mm / 2.36” free space from the rear of the light body to allow for the cable clearance. (See overall dimensions in the Appendix).

Ensure that the part of the light inside the vessel has a diameter of 60mm/ 2.36” free space around it free from any insulation material.

OceanLED recommends using a qualified installer / technician when making modifications to your vessel. Please also consult the manufacturer for more detail on modifications and installation.

OceanLED recommends use of provided screws. If alternative screws are used, do not use counter sunk or non-flat shoulder screws to secure your lights to the hull (failure to do so will invalidate your warranty).

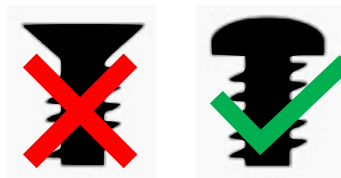

If lights are assembled in a conductive or wooden hull suitable fastening (marine grade) need to be used. The fastenings then should be bonded to the vessel cathodic protection system. Please contact OceanLED for additional details.

For the correct orientation of the light the logo should face upwards and parallel with the water line. See drilling template – in the Appendix, Chapter 7.

## Depth/Spacing

Ideally mount your lights at similar depth levels to ensure matching colour consistency through the water. Deeper lights will look duller and possibly differ in colour compared to shallower mounted units.

SPACING / INSTALL DEPTH	E2
Recommended Spacing	0.5-1.2m (2-4')
Recommended Installation depth (From the light waterline)	150-200mm (6-8")

## Maximum Hull Thickness

Maximum hull thickness: 50mm (2")

## Hole Cut Out

Hole Cut out size - 44mm (1.73")

## Overall Dimensions

See overall dimension schematic – in the Appendix, Chapter 7.

# 4 Installation

## 4.1 INSTALLING THE LIGHT FIXTURE

### DISCOVER D3

#### Kit Includes



Discover D3



3x Mounting Screws

#### Additional items required not supplied by OceanLED:

- Marine sealant - 3M 4200 or equivalent
- Cable ties
- Waterproof Cable Connectors / Junction Box\* (optional)
- Philips Screwdriver or Pozidrive #2 Screwdriver Bit
- 44mm (1.73") Hole Saw Cutter
- Drill Bit for mounting screw holes

\*Optional 4-Way Junction box available from OceanLED. Please contact OceanLED or your representative for further information.

 **OceanLED recommends dry fitting all products. Before applying sealant, please ensure the surface is clean of any dust, dirt or grease. When installing, be sure that the light fits the area and secures to the hull using the appropriate hardware before applying any sealant.**

 **When applying sealant to the light fixture, use OceanLED packaging material such as the light cardboard box when placing the light on the ground face down to prevent damage/ scratch of the front bezel.**

### Installation (Once hull preparation is complete)

1. Test light(s) before fitting.
2. Apply marine sealant to the rear of the front bezel to ensure a complete unbroken seal around the light.

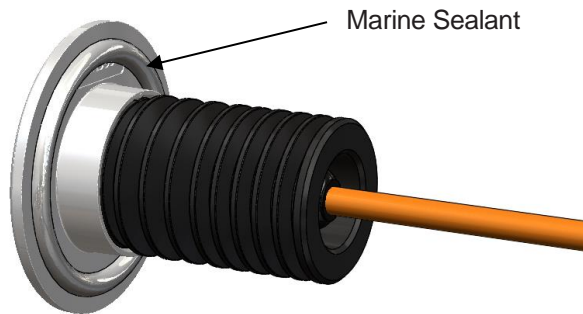

1. Start feeding the light cable through the hole. Ensure the correct orientation of the light unit with the logo facing upwards and mounting holes aligning with the pre-drilled pilot holes.

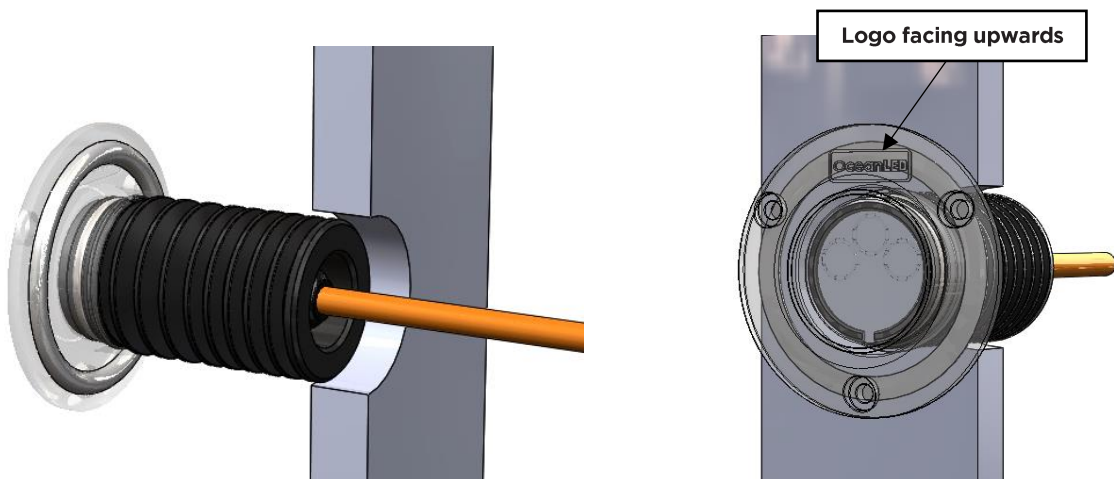

2. Insert the light into the hull, pressing the light hard into the hull and twist slightly to spread the sealant around behind the light to ensure good adhesion.

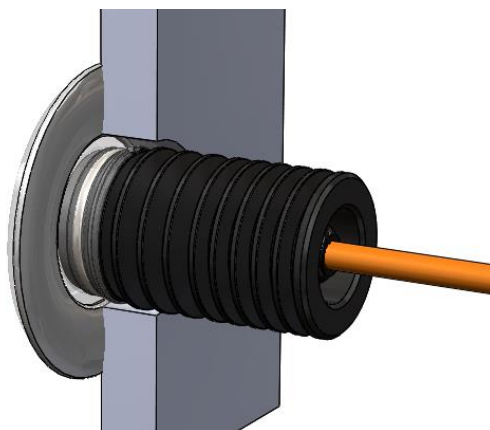

**!** Breakages due to lights falling out of the hull are NOT covered under warranty and can cause serious bodily injury as can any falling object.



3. Cover the screws threads with the sealant and screw into the pre-drilled pilot holes.
4. **Tighten the screws with a hand tool ONLY!** **DO NOT** over-tighten the screws, as you could damage the front bezel, and will void your warranty.



5. Once you are satisfied that the unit is fully tightened, you will notice that sealant has squeezed out from around the perimeter of the light. Using a cloth, wipe off excess sealant to leave a clean seal. If you do not see sealant squeeze out from the body, you have not used enough sealant or possibly tightened the unit enough to the hull. Carefully examine the installation to make sure the seal you have installed on the unit is fully watertight. If in doubt, remove light, re-apply sealant and re-install.



## 4.2 ELECTRICAL INSTALLATION (12/24V DC)

### Discover D3

#### Kit Includes



Fuse Kit

#### Additional items required not supplied by OceanLED:

- Junction box\* / waterproof connectors
- Sufficient cable to connect to DC Power Pack

\*Optional 4-Way Junction box available from OceanLED. Please contact OceanLED or your representative for further information.



**Always consult a qualified electrician when connecting OceanLED light fixtures.**

**When connecting light units, please note that all OceanLED lights will operate within a specific voltage range. Please check the electrical information to ensure cable gauge follow the recommendations.**

**Never leave the bare cables unprotected. Take care to not leave the bare wire ends in bilge water before making the waterproof connections. Water deposits in the connectors and cables will cause corrosion. Over time water can also work its way into the unit along the inside of the cable due to capillary action causing the light to fail. This will NOT be covered under warranty.**



**For complete instructions on DC connections, please refer to ABYC codes of practice and other applicable codes and ordinances for DC connections.**

**Where multiple lights are fitted, and especially on 12V systems, it is advised to use a relay system to supply the switched power to the lights, to reduce load on the switch and voltage drops caused by long cable runs to the switch location.**

1. Depending on the model and number of lights installed, you will need to pull the correct sized power cable from the DC power source (breaker/fuse panel) to the light locations to supply constant power to the light units. It is imperative that the correct sized tinned marine grade cable is used to avoid voltage drop issues.

See Chapter 7: Appendix for recommended cable gauges.

2. Using waterproof butt splices or IP66 waterproof junction boxes, make the connections at either end of the system to attach the lights to the DC system. Make sure any heatshrink used completely encapsulates the outer wire sheath (the use of glue-lined heat shrink is highly recommended to ensure water tightness).



**Never install a new light fixture then leave the vessel in the water unchecked for several days.**

3. It is imperative that either the OceanLED supplied fuse on each power line to each light or a suitable protection device is used to protect the cable/light unit. Failure to do so will void the warranty. See table in Chapter 2: Power Consumption and Recommended Fuse values. Make sure any heatshrink used completely encapsulates the outer wire sheath (the use of glue-lined heat shrink is highly recommended to ensure water tightness).
4. Secure cables ensuring where the cable exits the light it is not under undue stress. Finish and test the light units **BEFORE** the vessel goes into the water.

**Fuse Kit Connection Overview:**

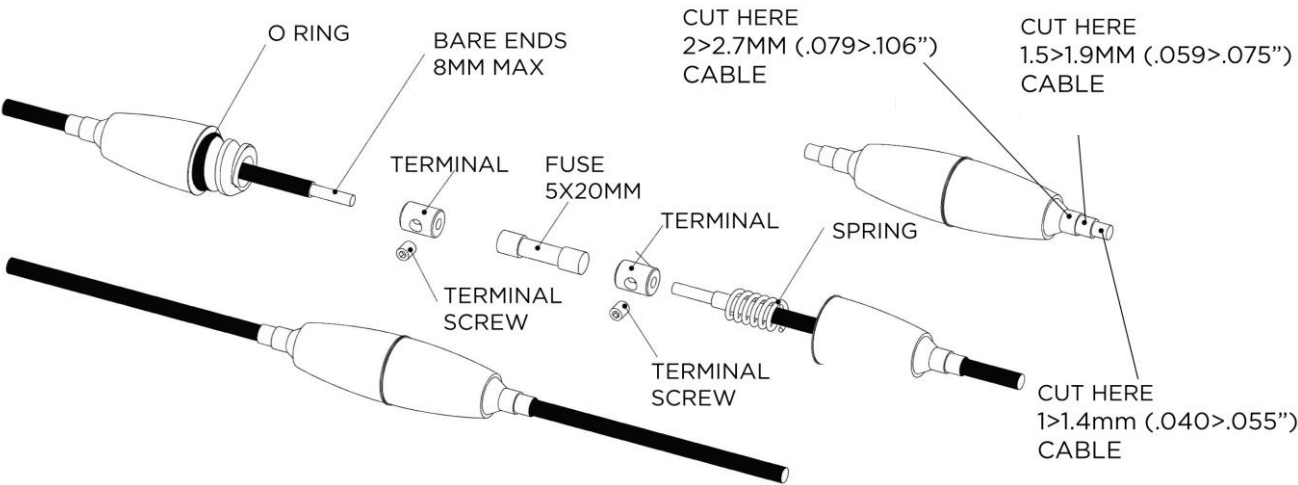

**12/24V DC Connection Diagram:**

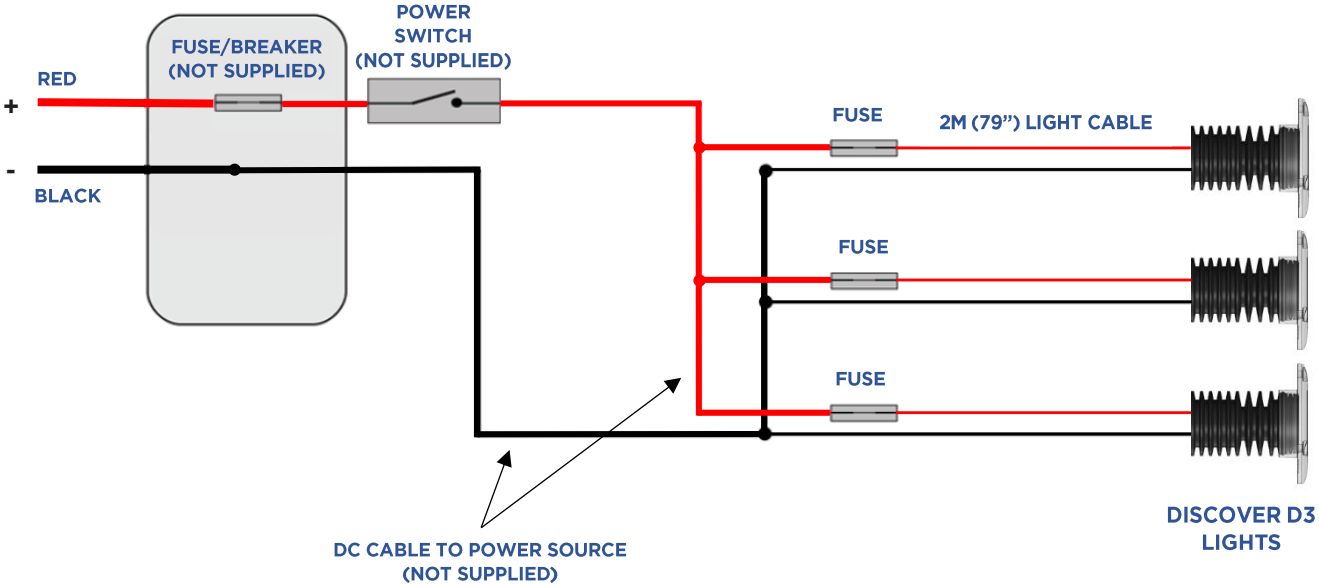

### Wiring Schematic with Power Junction Box:

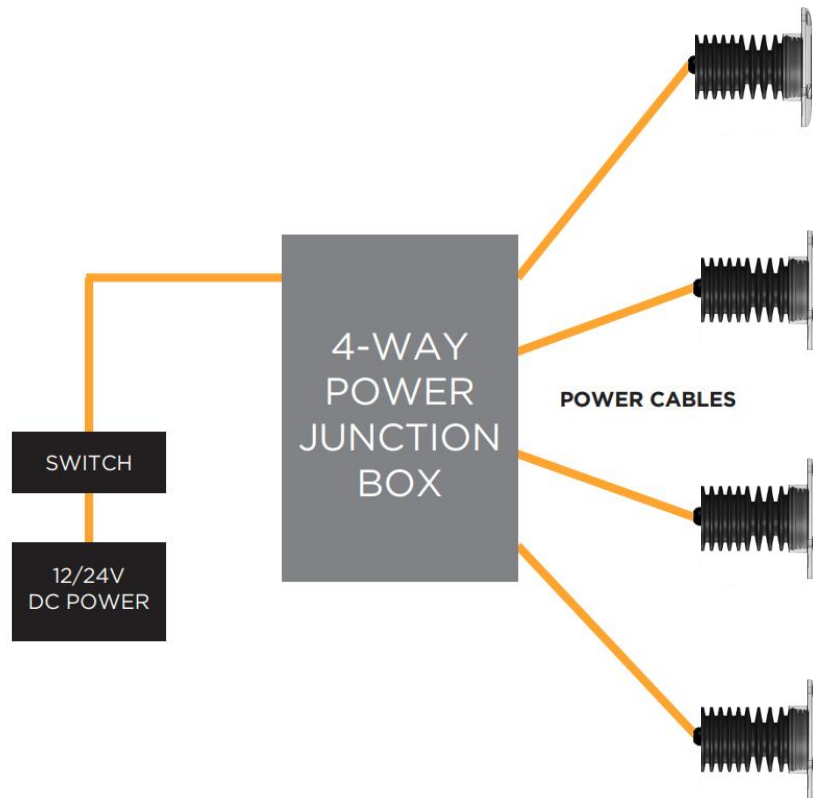

### 4.3 FINALISING THE INSTALLATION

The Discover D3 features a polymer front bezel that protects against corrosion as well as insulates against conductive hull types. The front face of the bezel is pre-coated with a specialized Tritonium® coating which helps to prevent marine growth from adhering to it. The light body is constructed from Hard Anodised Aluminium and does not require further protection.

**No paint or any type of anti-fouling agent should be applied to the bezel,** as damage may occur to the light due to chemical incompatibility and can affect the performance of the light and will immediately void the warranty.

**!** Please do not use any un-authorized cleaning products to remove excess paint or antifoul off the bezel. OceanLED recommends using Isopropyl Alcohol (IPA) only.

### 4.4 TEST YOUR INSTALLATION

Always test the lights **BEFORE** the vessel goes back into the water. At this final stage make sure all of the system is operational. If you have any issues, please contact your local OceanLED representative.

**!** Never install a new light fixture then leave the vessel in the water unchecked for several days.

When the vessel is placed in the water, immediately check for leaks. Note that very small leaks may not be readily observed. It is best not to leave the vessel in the water for more than 3 hours before checking it again. If there is a small leak, there may be considerable bilge water accumulation after 24 hours. If a leak is observed, you must **TAKE ACTION IMMEDIATELY** to prevent damage.

# 5 Operation / Maintenance

## 5.1 OPERATION

The Discover D3 light is available in either Midnight Blue or Ultra White models and therefore works only in standard single colour power mode.

## 5.2 MAINTENANCE

Marine growth can build up quickly on the light and can reduce the performance in just a few weeks.

To help prevent this, all OceanLED lights have been coated with a specialized Tritonium® coating which helps to prevent marine growth from adhering to the lens. Lights should be cleaned with a soft boat brush bi-weekly, or as needed to keep the lens of the light clean.

Growth varies greatly around the world and maintenance is imperative to the proper operation and longevity of the product. If heavy fouling occurs, barnacles can be removed from the lens using a plastic scraper and moderate pressure under water. If cleaning the lens while the boat is out of the water, wet the lens before scraping. Never scrape or try to remove barnacles from a dry lens.

# 6 Troubleshooting

## 6.1 TROUBLESHOOTING PROBLEMS AND THEIR SOLUTIONS

DISCOVER D3			
PROBLEM	CHECK	CAUSE	FIX
Light does not look bright	Check that there is no marine growth on the lens	Marine growth	Clean the lens as per maintenance advice
	Check voltage supply to the light is between 11V and 32V DC (The light will still work between 9 and 11 volts however at reduced brightness)	Voltage is either too high or too low	Investigate reason for high or low voltage and fix
	Check voltage supply is stable and does not fluctuate	Voltage is fluctuating	Investigate reason for voltage fluctuation and fix
	Check that the electrical connections between the light and the supply cable have been made correctly and recommended cable gauge has been used	Poor electrical connection	Remake connection and seal joint correctly
	Confirm all LEDs are illuminated	1 or more LEDs are not working	Contact your dealer.
	Check lights to see if water is present inside the light	Water present	Contact your dealer.
	Check cable connections for corrosion	If corrosion is present	It is not advised to reuse the cable if water is present inside. Contact your dealer for a replacement. This is NOT covered by the warranty
Light has water inside	Check connections to make sure they are not submerged in water	Light will require replacing	This is not covered by the warranty
	Check cable to make sure there is no damage to the cable	Cable will require replacing	This is not covered by the warranty. Only use genuine OceanLED parts
	Checked all factors that are above, and the light still does not work	Light faulty	Contact your dealer for a replacement light

DISCOVER D3			
PROBLEM	CHECK	CAUSE	FIX
Light does not light up	Check that the electrical connections between the light and the supply cable have been made correctly	Poor electrical connection	Remake connection and seal joint correctly
	Check that the wiring polarity is correct, red to positive and black to negative	Polarity incorrect	Change the wiring polarity and seal joint correctly
	Check that there is power supply to the light cable connection	Poor electrical connection	Trace the cables back, checking at joints until break has been located. Then rectify the problem and seal joint correctly
	Check that the electrical connections between the supply cable and the light circuit breaker or fuse have been made correctly	Poor electrical connection	Remake connection and seal joint correctly
	Check that the in-line fuse is intact and not blown	Replace fuse	If fuse keeps blowing, then there is a short circuit in the light system that must be traced and rectified. If no external short can be located contact your dealer
	Check that the light supply circuit breaker is closed, or the fuse has not blown	Close circuit breaker / replace fuse	If breaker / fuse keeps blowing, then there is a short circuit in the light system that must be traced and rectified. If no external short can be located contact your dealer

# 7 Appendix

## 7.1 OVERALL DIMENSIONS

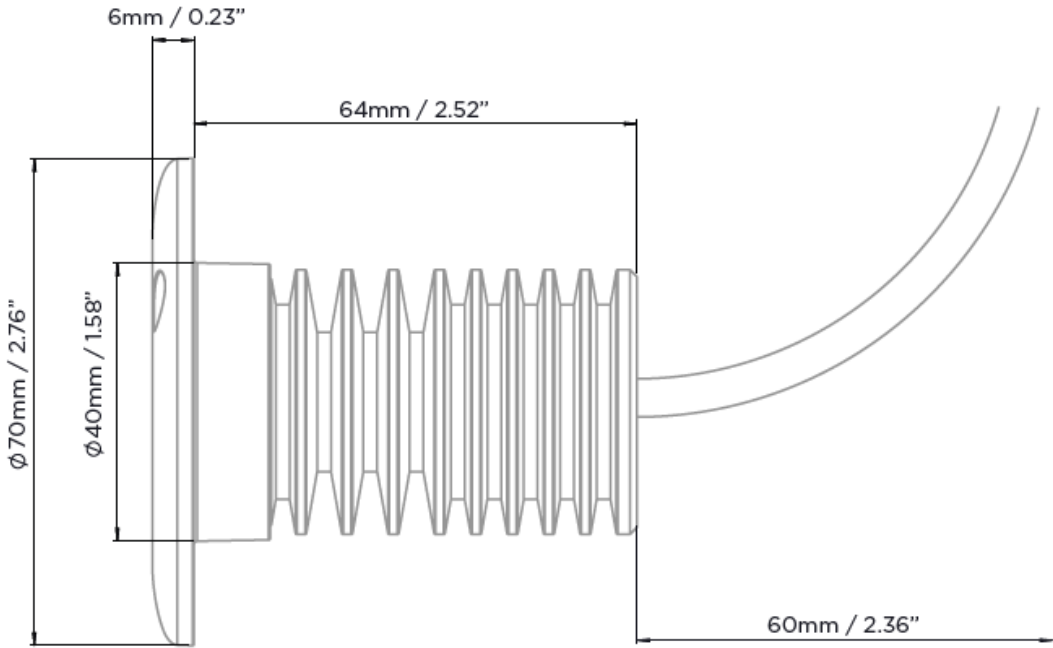

## 7.2 DRILLING TEMPLATE

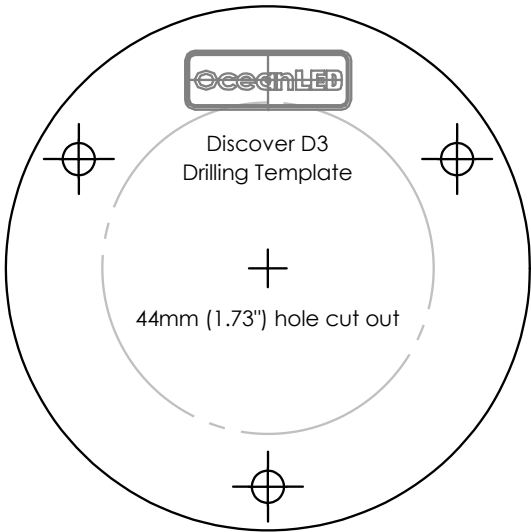
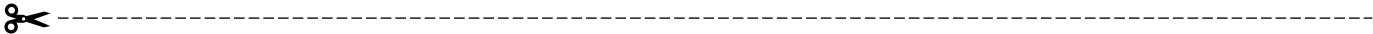

Print A4 at 100% for correct scaling.



### 7.3 CABLE GAUGE CHART 12V

Supply & Return Cable Conductor Size Chart 3% drop for when using 12V DC supply											
Cable length (feet)*	Circuit Current										
	2 Amp	4 Amp	6 Amp	8 Amp	10 Amp	15 Amp	20 Amp	25 Amp	30 Amp	40 Amp	50 Amps
0-5	18 AWG	18 AWG	16 AWG	16 AWG	14 AWG	12 AWG	12 AWG	10 AWG	10 AWG	8 AWG	8 AWG
5-10	18 AWG	16 AWG	14 AWG	12 AWG	12 AWG	10 AWG	8 AWG	8 AWG	6 AWG	6 AWG	4 AWG
10-15	16 AWG	14 AWG	12 AWG	10 AWG	10 AWG	8 AWG	6 AWG	6 AWG	4 AWG	4 AWG	2 AWG
15-20	16 AWG	12 AWG	10 AWG	10 AWG	8 AWG	6 AWG	6 AWG	4 AWG	4 AWG	2 AWG	2 AWG
20-25	14 AWG	12 AWG	10 AWG	8 AWG	8 AWG	6 AWG	4 AWG	4 AWG	2 AWG	2 AWG	1 AWG
25-30	14 AWG	10 AWG	10 AWG	8 AWG	6 AWG	4 AWG	4 AWG	2 AWG	2 AWG	1 AWG	0 AWG
30-35	14 AWG	10 AWG	8 AWG	8 AWG	6 AWG	4 AWG	4 AWG	2 AWG	2 AWG	1 AWG	0 AWG
35-40	12 AWG	10 AWG	8 AWG	6 AWG	6 AWG	4 AWG	2 AWG	2 AWG	1 AWG	0 AWG	2/0 AWG
40-45	12 AWG	10 AWG	8 AWG	6 AWG	4 AWG	4 AWG	2 AWG	2 AWG	1 AWG	0 AWG	2/0 AWG
45-50	12 AWG	8 AWG	6 AWG	6 AWG	4 AWG	2 AWG	2 AWG	1 AWG	0 AWG	2/0 AWG	3/0 AWG
50-55	12 AWG	8 AWG	6 AWG	6 AWG	4 AWG	2 AWG	2 AWG	1 AWG	0 AWG	2/0 AWG	3/0 AWG
55-60	10 AWG	8 AWG	6 AWG	4 AWG	4 AWG	2 AWG	1 AWG	0 AWG	0 AWG	3/0 AWG	4/0 AWG
60-65	10 AWG	8 AWG	6 AWG	4 AWG	4 AWG	2 AWG	1 AWG	0 AWG	2/0 AWG	3/0 AWG	4/0 AWG
65-70	10 AWG	8 AWG	6 AWG	4 AWG	4 AWG	2 AWG	1 AWG	0 AWG	2/0 AWG	3/0 AWG	4/0 AWG
70-75	10 AWG	6 AWG	4 AWG	4 AWG	2 AWG	2 AWG	0 AWG	2/0 AWG	2/0 AWG	4/0 AWG	
75-80	10 AWG	6 AWG	4 AWG	4 AWG	2 AWG	1 AWG	0 AWG	2/0 AWG	3/0 AWG	4/0 AWG	
80-85	10 AWG	6 AWG	4 AWG	4 AWG	2 AWG	1 AWG	0 AWG	2/0 AWG	3/0 AWG	4/0 AWG	
85-90	10 AWG	6 AWG	4 AWG	4 AWG	2 AWG	1 AWG	0 AWG	2/0 AWG	3/0 AWG	4/0 AWG	
90-95	8 AWG	6 AWG	4 AWG	2 AWG	2 AWG	1 AWG	2/0 AWG	3/0 AWG	3/0 AWG		
95-100	8 AWG	6 AWG	4 AWG	2 AWG	2 AWG	0 AWG	2/0 AWG	3/0 AWG	4/0 AWG		

\*One-way cable length from supply (usually battery) to load.

## 7.4 CABLE GAUGE CHART 24V

Supply & Return Cable Conductor Size Chart 3% drop for when using 24V DC supply											
Cable length (feet)*	Circuit Current										
	2 Amp	4 Amp	6 Amp	8 Amp	10 Amp	15 Amp	20 Amp	25 Amp	30 Amp	40 Amp	50 Amps
0-5	18 AWG	18 AWG	18 AWG	18 AWG	18 AWG	16 AWG	14 AWG	14 AWG	12 AWG	12 AWG	10 AWG
5-10	18 AWG	18 AWG	16 AWG	16 AWG	14 AWG	12 AWG	12 AWG	10 AWG	10 AWG	8 AWG	8 AWG
10-15	18 AWG	16 AWG	14 AWG	14 AWG	12 AWG	12 AWG	10 AWG	8 AWG	8 AWG	6 AWG	6 AWG
15-20	18 AWG	16 AWG	14 AWG	12 AWG	12 AWG	10 AWG	8 AWG	8 AWG	6 AWG	6 AWG	4 AWG
20-25	18 AWG	14 AWG	12 AWG	12 AWG	10 AWG	8 AWG	8 AWG	6 AWG	6 AWG	4 AWG	4 AWG
25-30	16 AWG	14 AWG	12 AWG	10 AWG	10 AWG	8 AWG	6 AWG	6 AWG	4 AWG	4 AWG	2 AWG
30-35	16 AWG	14 AWG	12 AWG	10 AWG	10 AWG	8 AWG	6 AWG	6 AWG	4 AWG	4 AWG	2 AWG
35-40	16 AWG	12 AWG	10 AWG	10 AWG	8 AWG	6 AWG	6 AWG	4 AWG	4 AWG	2 AWG	2 AWG
40-45	14 AWG	12 AWG	10 AWG	10 AWG	8 AWG	6 AWG	4 AWG	4 AWG	4 AWG	2 AWG	2 AWG
45-50	14 AWG	12 AWG	10 AWG	8 AWG	8 AWG	6 AWG	4 AWG	4 AWG	2 AWG	2 AWG	1 AWG
50-55	14 AWG	12 AWG	10 AWG	8 AWG	8 AWG	6 AWG	4 AWG	4 AWG	2 AWG	2 AWG	1 AWG
55-60	14 AWG	10 AWG	10 AWG	8 AWG	6 AWG	4 AWG	4 AWG	2 AWG	2 AWG	1 AWG	0 AWG
60-65	14 AWG	10 AWG	8 AWG	8 AWG	6 AWG	4 AWG	4 AWG	2 AWG	2 AWG	1 AWG	0 AWG
65-70	14 AWG	10 AWG	8 AWG	8 AWG	6 AWG	4 AWG	4 AWG	2 AWG	2 AWG	1 AWG	0 AWG
70-75	12 AWG	10 AWG	8 AWG	6 AWG	6 AWG	4 AWG	2 AWG	2 AWG	2 AWG	0 AWG	2/0 AWG
75-80	12 AWG	10 AWG	8 AWG	6 AWG	6 AWG	4 AWG	2 AWG	2 AWG	1 AWG	0 AWG	2/0 AWG
80-85	12 AWG	10 AWG	8 AWG	6 AWG	6 AWG	4 AWG	2 AWG	2 AWG	1 AWG	0 AWG	2/0 AWG
85-90	12 AWG	10 AWG	8 AWG	6 AWG	4 AWG	4 AWG	2 AWG	2 AWG	1 AWG	0 AWG	2/0 AWG
90-95	12 AWG	8 AWG	8 AWG	6 AWG	4 AWG	4 AWG	2 AWG	1 AWG	1 AWG	2/0 AWG	2/0 AWG
95-100	12 AWG	8 AWG	6 AWG	6 AWG	4 AWG	2 AWG	2 AWG	1 AWG	0 AWG	2/0 AWG	3/0 AWG

\*One-way cable length from supply (usually battery) to load.



