

CONTENTS

1	PRECAUTIONS – WARRANTY	27
2	OPERATING-PRESENTATION-INTERFACES.....	27
2.1	OPERATING PRINCIPLE.....	27
2.2	OVERVIEW.....	27
2.3	USER INTERFACE	28
2.4	CONNEXION AREA.....	29
3	INSTALLATION.....	29
3.1	CHARGER OVERALL DIMENSIONS.....	30
3.2	WIRING.....	30
3.2.1	TYPICAL INSTALLATION.....	31
3.2.2	CABLE FROM THE PUBLIC AC POWER SUPPLY NETWORK OR GENERATOR	31
3.2.3	BATTERY CABLES.....	33
3.2.4	ELECTROMAGNETIC DISTURBANCE.....	34
3.3	CONFIGURATION - ADJUSTMENT – INDICATORS	34
3.3.1	SETTING BY PUSH-BUTTONS	34
3.3.2	SETTING THE CHARGER WITH BLUETOOTH	35
3.3.3	ADVANCE SETTINGS.....	39
3.3.4	CANBUS	40
3.4	OPTIONS AND FEATURES	41
3.4.1	COMPENSATION TEMPERATURE PROBE (OPTIONAL)	41
3.4.2	OTD (OPTIONAL).....	41
3.4.3	STANDBY MODE	41
3.5	FACTORY SETTINGS.....	41
3.6	CHARGING CURVE.....	42
3.6.1	BOOST AND REFRESH IN ON POSITION	42
3.6.2	BOOST AND REFRESH IN OFF POSITION	43
3.6.3	BOOST IN ON AND REFRESH IN OFF POSITION	43
3.7	INDICATORS	44
3.8	THERMAL PERFORMANCE	45
4	EQUIPMENT MAINTENANCE AND REPAIRS.....	45
4.1	OVERVIEW.....	45
4.2	EQUIPMENT MAINTENANCE.....	45
4.3	EQUIPMENT REPAIRS.....	45
5	TECHNICAL SPECIFICATIONS.....	46
6	SAFETY WARNINGS AND CONDITIONS OF WARRANTY.....	47
6.1	PRECAUTIONS (WARNING) – PROVISIONS RELATING TO SAFETY	47
6.2	WARRANTY.....	48

1 PRECAUTIONS – WARRANTY

The CRISTEC equipment includes the following:

- A box containing the battery charger's electronic function.
- AC input connector (Except OE VERSION)
- DC output connector (Except OE VERSION)
- This user manual
- Specific packing

This document applies to battery chargers from the **YPOWER⁺** range as listed on the cover, available in colour on our website www.cristec.fr/

The manual is intended for users, installers and equipment maintenance staff. Please read this manual carefully before working on the charger.

This manual should be kept safely and consulted before attempting any repairs because it contains all the information required to use the appliance.

This document is the property of CRISTEC; all the information it contains applies to the accompanying product. CRISTEC reserves the right to modify the specifications without notice.

Before starting installation, it is mandatory to read safety instructions and warranty conditions described in chapter 6.

2 OPERATING-PRESENTATION-INTERFACES

2.1 OPERATING PRINCIPLE

The design of the battery chargers in the **YPOWER⁺** range is based on a high-frequency switching supply converter that transforms the AC signal into regulated and filtered DC current. They can operate as a DC power supply.

Once the type of battery and type of charge have been selected, operation of the battery charger is entirely automatic (unless otherwise specified by the supplier or the manufacturer of the batteries). It can remain connected to the batteries and does not need to be disconnected when starting up an engine (marine application), because it is equipped with an integrated separator.

The appliance's output voltage is sufficient to recharge 1, 2, or 3 separate batteries (integrated charge distributor, separation of batteries). The charger's maximum output is the rated current distributed to each output according to the connected batteries banks.

Each output can deliver the rated current.

The unused outputs have to be left unconnected

2.2 OVERVIEW

The chargers are divided into 2 zones:

- The user interface (see 2.3)
- The connexion zone (see 2.4)

Fixing of the charger is made by 4 x M5 round head screws (screw head diameter less than 10 mm).
Centre distance: see section 3.1.

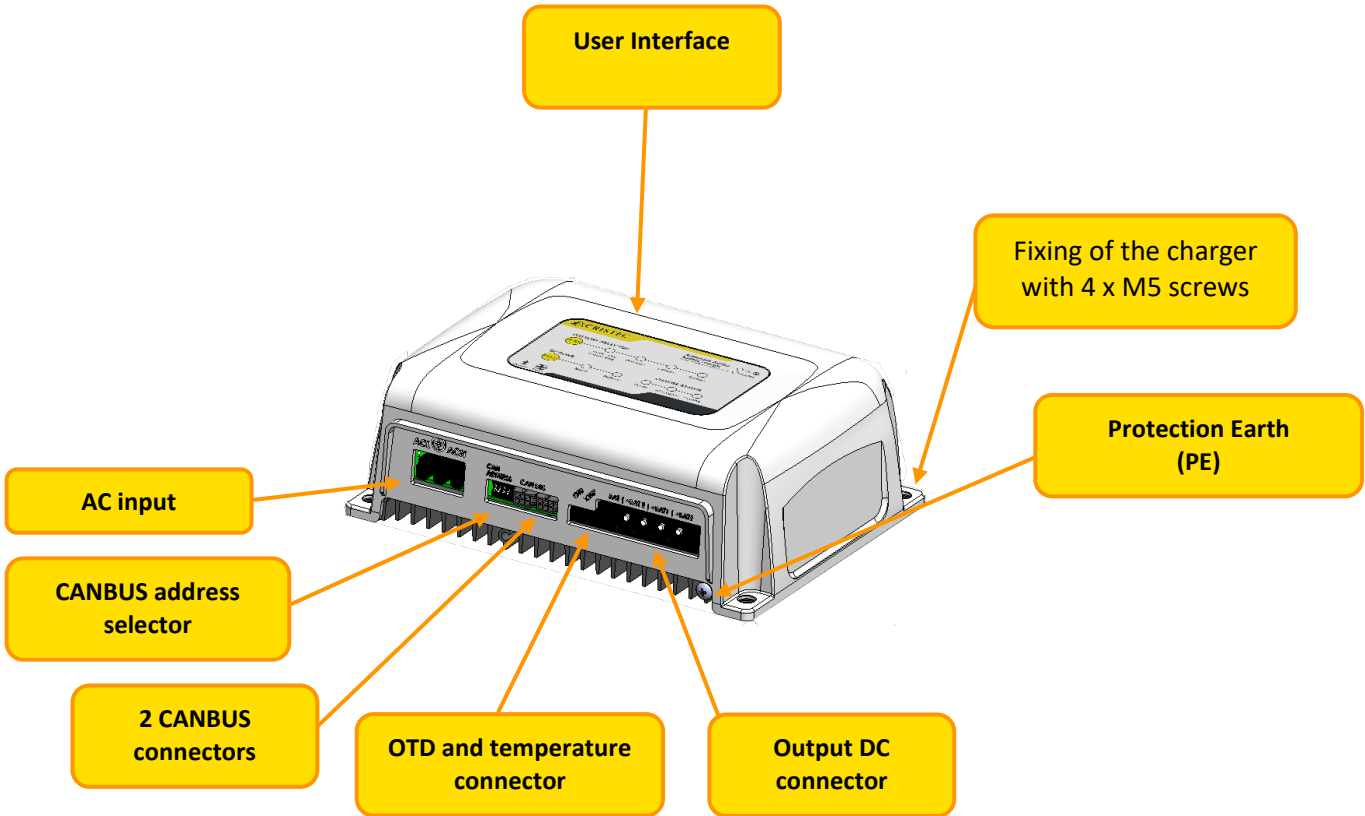

2.3 USER INTERFACE

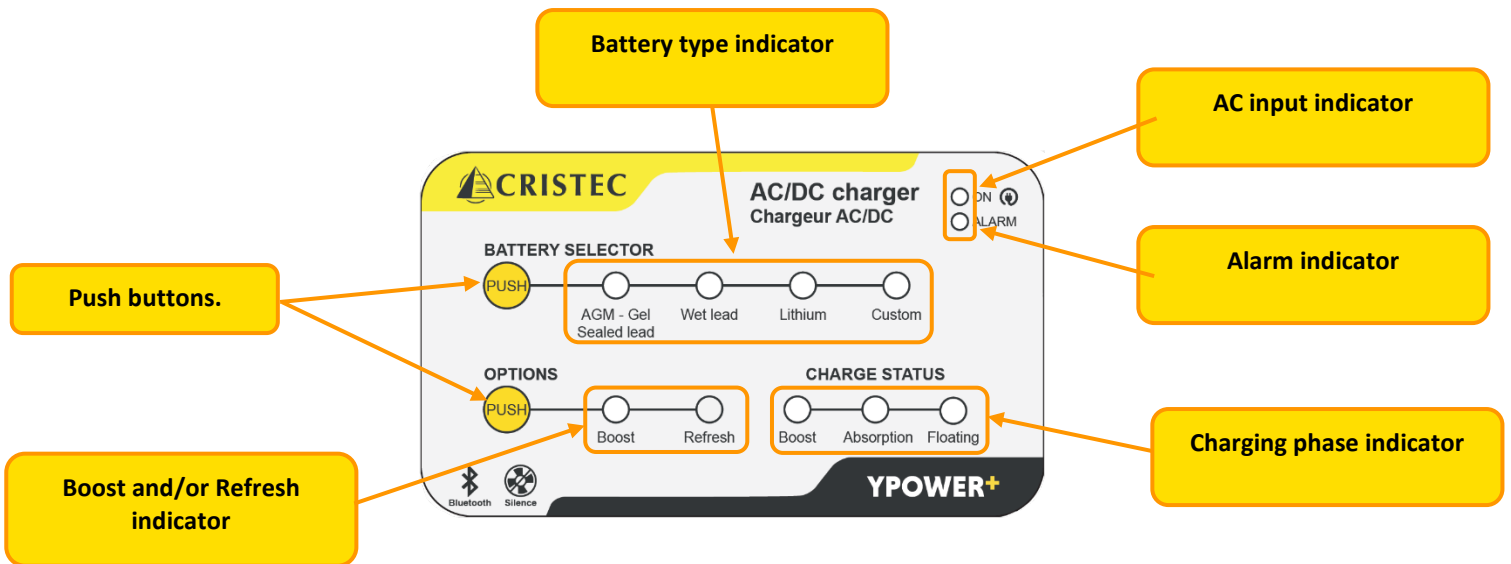

2.4 CONNEXION AREA

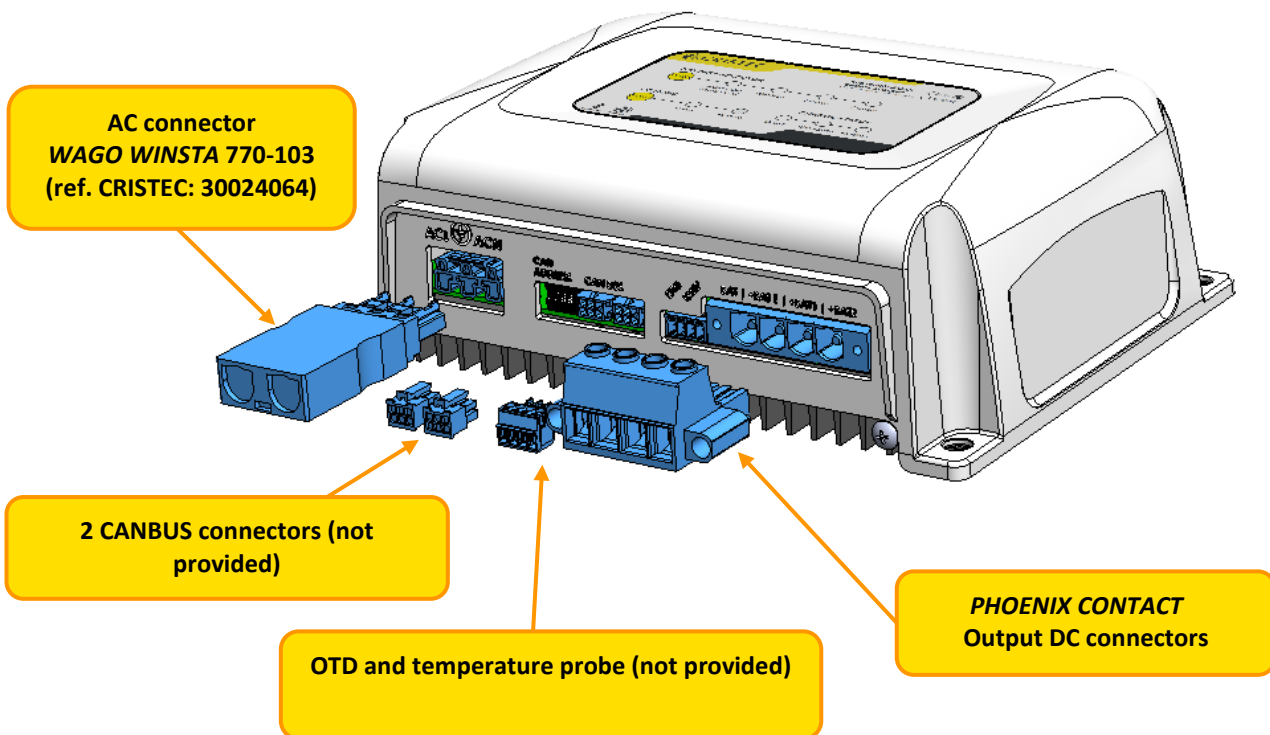

3 INSTALLATION

This paragraph deals with installation of the equipment.

Installation and initial commissioning should be carried out by an electrician or professional installer in accordance with the standards currently in force (for leisure boats the applicable international standard is ISO13297).

The installer should familiarize himself with this operating manual and inform users of the instructions for use and the safety warnings set out in the manual.

3.1 CHARGER OVERALL DIMENSIONS

Chargers **YPOWER+** 12-20, 12-30, 24-15

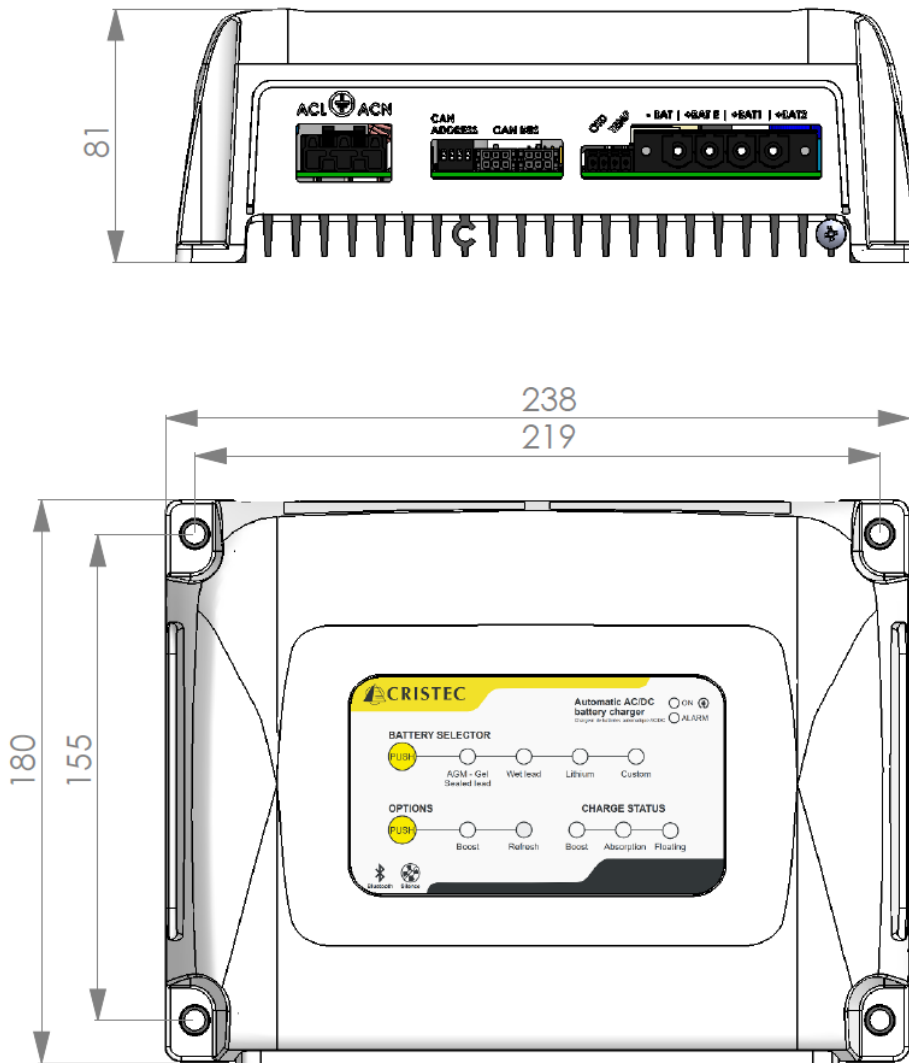

3.2 WIRING

When connecting or disconnecting a cable, the charger's power supply must be turned off and the batteries electrically insulated from the charger.

The references for additional cables and connectors required for the appliance to operate efficiently are provided in the following paragraphs: failure to comply with these provisions renders the warranty null and void.

3.2.1 Typical installation

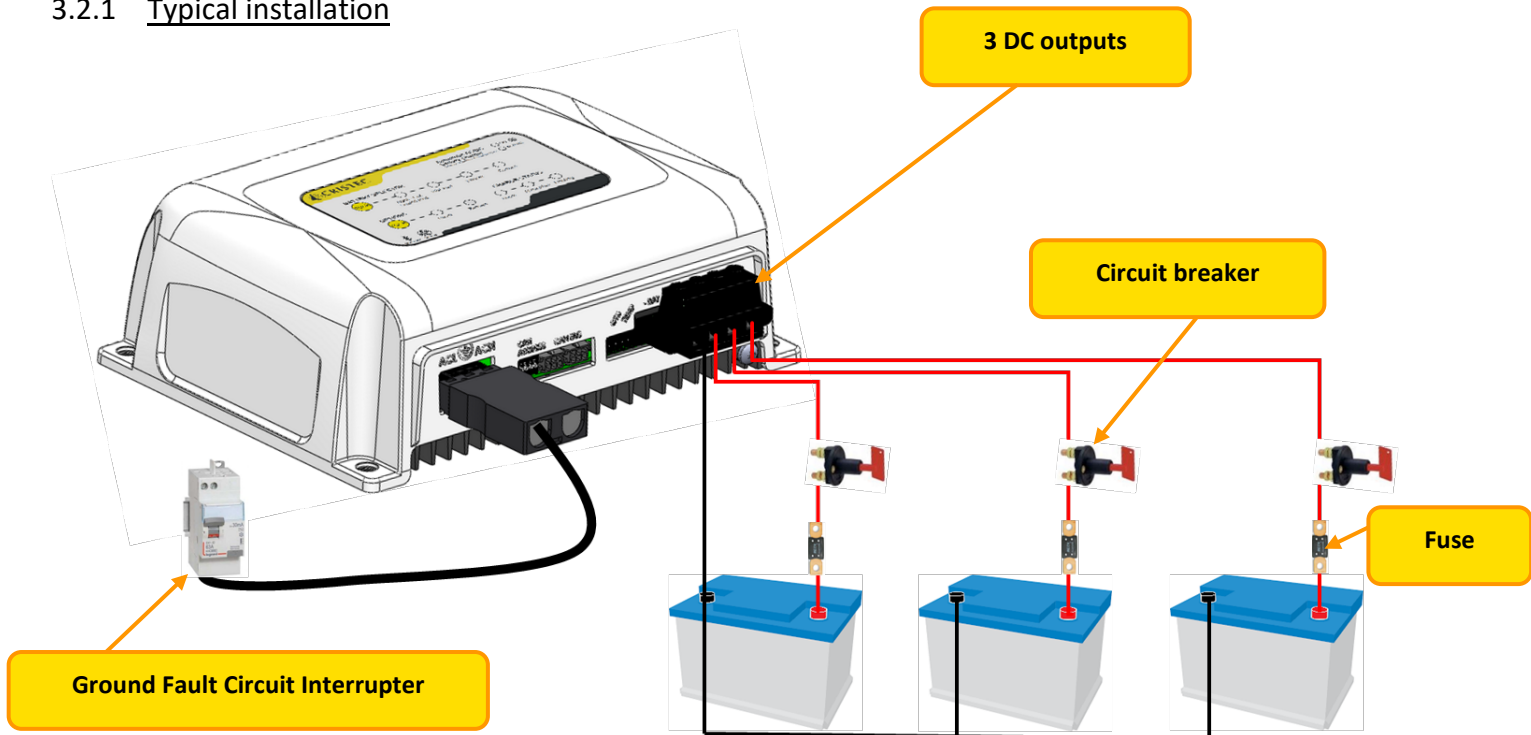

3.2.2 Cable from the public AC power supply network or generator

Disconnect AC network before any wiring and connecting of the connector.

All **YPOWER+** battery chargers can operate automatically and equally on single phase networks from 90 to 265VAC and from 47 to 65Hz.

Generators

CRISTEC battery chargers are designed to operate from a generator.



Be careful: In some cases, the generators can produce high over voltages, in particular during start-up phase. Before connecting the charger, please check its compatibility with the characteristics of the generator: power, voltage, overvoltage, frequency, current, etc.

It's highly advised to disconnect the charger from the AC network during the generator starting phase.

Any damage to the charger due to a voltage surge will be excluded from the warranty.

The **AC power cables** must be at least equal to or greater than the values provided in the table below (depending on the length of the cable):

Model	Minimum cross-section for 115VAC	Minimum cross-section for 230VAC
YPOWER+ 12-16, 12-25, 24-12	3 x 1,5 mm ²	

The table below shows the maximum cross-section of the AC power supply cable admissible at the input of the connector:

Model	maximum cross-section
YPOWER+ 12-20, 12-30, 24-15	2 cables of 3 wires of 4mm ²

WAGO WINSTA connector reference 770-103 allows the insertion of 2 cables made with 3 wires of 4mm² each.

The type of cable (H07-VK, MX, etc.) should be defined by the installer according to the application type and applicable standards.

For applications where the electricity network may be either 115VAC or 230VAC, always choose the cross section recommended for 115VAC.

Always use cable markers without insulating collars in accordance with installation standards governing AC network input connections.

The rating of the upstream circuit-breakers should match the equipment's requirements.

Mounting of AC supply connector

The AC input must be made using a WAGO connector type WINSTA reference 770-103. (Not provided in OE version).

	<p>Strip the cable about 3cm.</p>
	<p>Strip 3 wires about 8mm. Tin the end of bare copper or crimp a wire tip without collar.</p>
	<p>Open the housing. Remove the cable seal from the housing.</p>
	<p>Pass a flat screwdriver into the square hole to open the contact and insert the wire.</p>
	<p>Carry out this operation on the 3 wires, respecting polarity. ⊕ : Earth N : Neutral L : Phase</p>
	<p>Position the connector in the housing, making sure that the cable enters by 1cm approx. Close the sides of the housing and screw.</p>

Remarks:



The **YPOWER+** chargers are working as soon as they are powered on (AC cable connected and powered).

The **YPOWER+** chargers are stopped:

- as soon as they are no longer under AC voltage (power off delay of 20 seconds) and the output DC network is disconnected for an activated standby mode.
- as soon as they are no longer under AC voltage (power off delay of 20 seconds) for deactivated standby mode.

Indeed, the charger can still be active even if the AC input has been disconnected (see 3.4.3).

3.2.3 Battery cables

Disconnect batteries before any wiring and junction of the connector.

Please check the compatibility of voltage, current and setting according to the battery type before switching ON the charger.

Checking of the charge voltage

Before connecting the batteries to the charger, first check their polarity.

Check also the battery voltage with a calibrated voltmeter. A too low voltage value on some types of batteries shows irreversible damage and impossibility to recharge.

Any damage due to incorrect connections will be excluded from the warranty.

The table below defines the maximum battery cable cross-section allowable for the output connector:

Model	Maximum allowable battery cable cross-section
YPOWER+ 12-20, 12-30, 24-15	16mm ²

The installer should choose the type of cable (H07-VK, MX, etc.) according to the type of application and the applicable standards.

The DC outputs must use a PHOENIX CONTACT connector type. Unused terminals should remain unconnected.

Model	PHOENIX CONTACT connector reference
YPOWER+ 12-20, 12-30, 24-15	PC 16/4-STF-10,16 BK (reference CRISTEC 30033787)

PHOENIX CONTACT connector junction

Connect from left to right: -BAT, +BAT E, + BAT 1 and +BAT 2 on all **YPOWER+** models

- - BAT (minus set of batteries)
- +BAT E (plus engine battery)
- +BAT 1 (plus battery set 1)
- +BAT 2 (plus battery set 2)

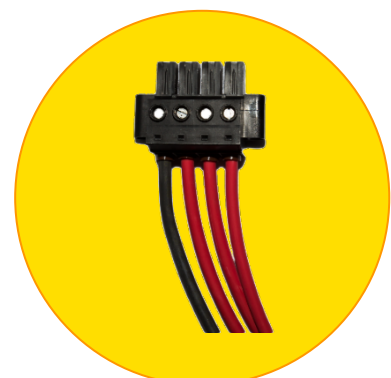

3.2.4 Electromagnetic disturbance

We recommend a minimum distance of 2m between the charger and any potentially sensitive equipment.

Use shielded cables for all the connections (*). The shielding should be earthed at both the transmitting and the receiving ends.

Keep cable length and shielding connections to a minimum.

Route cables as close as possible to conductive parts ("loose" cables or loops should be avoided – cables should be placed against the hull or walls).

Keep power cables separate from battery cables.

Keep power cables separate from control cables (at least 200mm).

The cables should only supply power to this appliance; any deviation to power another appliance is prohibited.

(*) This is a recommendation for installation rather than an obligation. The installing electrician should decide whether or not to use shielded cable depending on the EMC environment.

3.3 CONFIGURATION - ADJUSTMENT – INDICATORS

The charger **YPOWER+** can be configured in 3 different ways.

- Via parameter push-buttons (see section 3.3.1)
- Via Bluetooth (see section 3.3.2)
- Via CANBUS (see section 3.3.4)

3.3.1 Setting by push-buttons

*The **YPOWER+** chargers are equipped with 2 parameter buttons for configuring the charger, including battery type (see section 3.3.1.1) and activation of BOOST and REFRESH modes (see section 3.3.1.2).*

A first short press unlocks the settings, and allows you to modify the parameters by pressing the buttons in succession. Each press on one of the buttons changes the field, and a LED indicates the charger's status.

3.3.1.1 change battery type

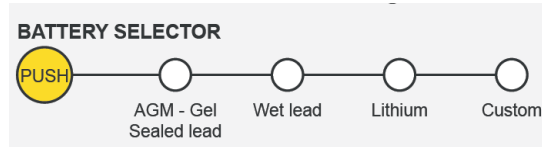

Configuration according to 12V or 24V battery type

Description of the battery type	Floating voltage 12V/24V	Boost voltage 12V/24V	Maximum duration of BOOST at +/- 5% T _{BOOST}	Maximum duration of ABSORPTION at +/- 5% T _{ABS}
FACTORY SETTING (by default)				
AGM / GEL/ Sealed lead Classic sealed type (Sealed lead)	13.8V/27.6V	14.4V/28.8V	2H	4H
Wet lead Opened type bat free electrolyte	13.4V/26.8V	14.1V/28.2V	2H	4H
Lithium (LiFePO4) with BMS (***)	13.8V/27.6V	14.4V/28.8V	6H	1H
Custom	Via Bluetooth			

(*) Voltage on + BAT 1, + BAT 2 and + BAT E with 10% of the rated current and a tolerance of +/- 1%.
The voltages values must be doubled for 24V batteries.

(**) REFRESH is not advised for certain types of AGM batteries

(***) Battery Management System

3.3.1.2 Boost and Refresh mode

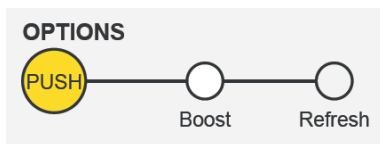

BOOST mode	REFRESH mode
OFF	OFF
FACTORY SETTING (by default)	
ON	OFF
OFF	ON
ON	ON

- The BOOST function enables faster recharging of the batteries.

- The REFRESH function applies a voltage step periodically to maintain and equalize the battery, thus preventing sulphation. (see chapter 3.6).

3.3.2 Setting the charger with Bluetooth

The **Cristec Connect** Bluetooth application is available on the Apple Store and Play Store, enabling remote wireless connection to the device, as well as device supervision and configuration. The complete application manual is available on our website:

www.cristec.fr



3.3.2.1 Activate Bluetooth on your phone or tablet

3.3.2.2 Add the charger

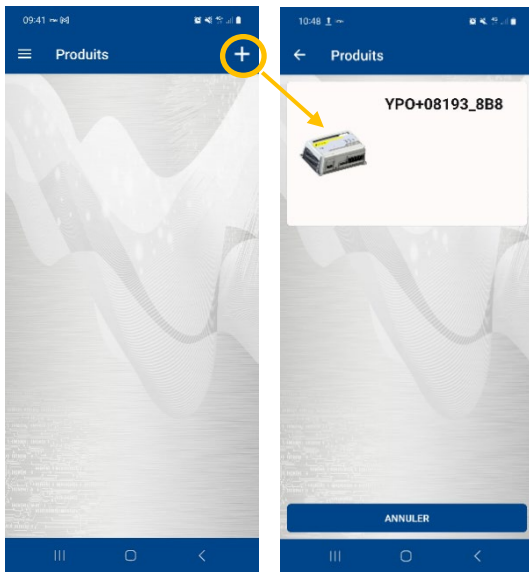

The charger may already be present when you open the application, if you've already installed it. If not, you can always add a device by pressing the + button at the top right of the screen. When the charger appears, simply click on it to add it to the application.

If no charger appears after 30 seconds:

- Check that the charger is powered
- Check that Bluetooth is enabled on your phone or tablet.

To delete a device, slide the charger to the right until the recycle garbage can appears. Then confirm.

To delete a device, slide the loader to the right until the recycle garbage can appears. Then confirm.

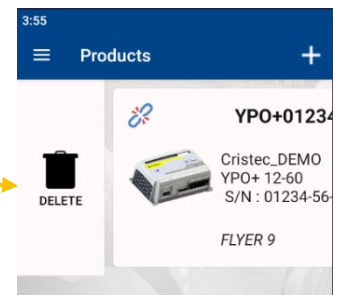

3.3.2.3 Monitoring

When you click on the connected charger, a page with various data appears. This is the supervision page. The Bluetooth connection icon appears, but you don't necessarily have access to the charger's settings.

To access the charger settings, press the wheel on the right of the screen (see chapter 3.3.2.5).

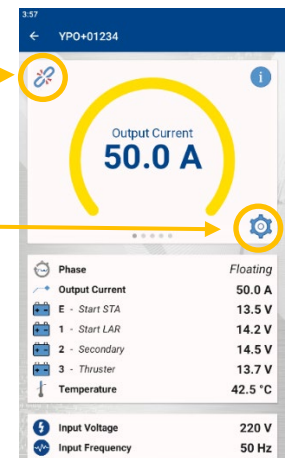

At the top of the screen, you can scroll through voltage and current information of the various batteries.

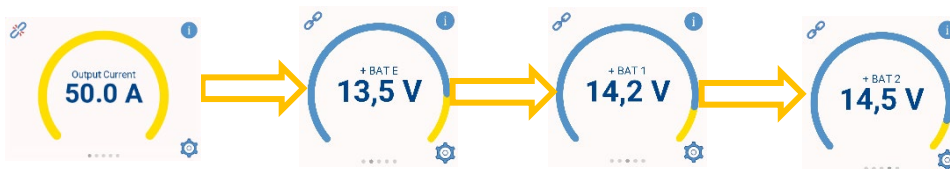

The lower section displays charge phase information, charger voltage and current, temperature (with optional sensor) and AC input voltage and frequency.

Phase	Floating
Output Current	50.0 A
E - Start STA	13.5 V
1 - Start LAR	14.2 V
2 - Secondary	14.5 V
3 - Thruster	13.7 V
Temperature	42.5 °C

Input Voltage	220 V
Input Frequency	50 Hz

3.3.2.4 Pin code

When you click on the cogwheel, you can enter the charger's configuration menus. The application asks you to enter a pin code. Enter 6 zeros by default, then press ok



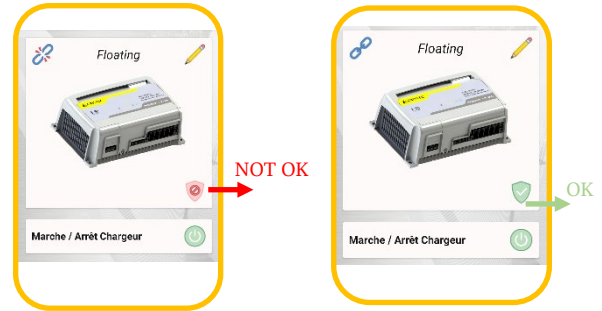

"000000" + OK

You can change the default pin code in the application (see 3.3.3.1).

If charger control is enabled, the shield on the control page appears in green. Otherwise, it appears in red.



3.3.2.5 charger control

	Charger control activated
	Turn the charger ON or OFF
	Current counter in Ah (reset button)
	Access to load curves (see 3.3.2.6)
	Advanced settings (see 3.3.3)

3.3.2.6 Charging curve

You can select the charging curve corresponding to your batteries by scrolling through the battery types. Once you've selected the battery type, two graphs show how the charger behaves in terms of voltage and current. A table at the bottom of the page summarizes these data:

Boost+ABS Time	<u> </u> 0 h	Cumulative boost and absorption duration
Boost Voltage	<u> </u> 0 V	Boost voltage
Float Voltage	<u> </u> 0 V	Float voltage
Current Level	<u> </u> 0 A	Current threshold for switching from absorption to Floating
Current	<u> </u> 60 A	Nominal charger output current

These data cannot be modified*; they are provided for information purposes only.
 (* In order to modify this data, you must enter customization mode, see 3.3.2.8)

You can select the following charging curves:

Description of the battery type	Floating voltage 12V/24V	Boost voltage 12V/24V	Maximum duration of BOOST at +/- 5% T _{BOOST}	Maximum duration of ABSORPTION at +/- 5% T _{ABS}
Opened type bat free electrolyte (wet)	13.4V/26.8V	14.1V/28.2V	2H	4H
GEL/AGM/ Sealed lead	13.6V/27.2V	14.4V/28.8V	2H	4H
Spiral type bat	13.6V/27.2V	14.4V/28.8V	2H	4H
Tin calcium lead bat	14.4V/28.8V	15.1V/30.2V	2H	4H
Wintering or standby sealed bat	13.4V/26.8V	13.4V/26.8V	0H	0H
Stabilized DC power supply	12.0V/24.0V	12.0V/24.0V	0H	0H
SPE1 open type bat	13.2V/26.4V	14.8V/29.6V	2H	4H
Lithium (LiFePO4) with BMS (***)	13.8V/27.6V	14.4V/28.8V	6H	1H
STORMLINE Batt	13.7V/27.4V	14.5V/29V	2H	6H
CUSTOM*	13.8V/27.6V	14.4V/28.8V	2H	4H

*Custom mode values are customizable (see 3.3.2.8).

3.3.2.7 Boost and Refresh

Boost and Refresh modes are selected by activating the corresponding checkmarks:



3.3.2.8 Custom mode



Custom mode lets you modify the values of the charger's predefined charge curves.

Warning: Customization of the charging curve, and therefore modification of the parameters described in this document, is the responsibility of the end user. It is not advisable to modify these parameters unless you are fully conversant with all aspects of chargers and battery specifications.

Cristec cannot be held responsible for any problems caused by the end user modifying the load curves.

Once the custom mode is set, you can modify the values of the following parameters**:

Boost+ABS Time	_____ 0 h	: Cumulative boost and absorption duration
Boost Voltage	_____ 0 V	: Boost voltage
Float Voltage	_____ 0 V	: Float voltage
Current Level	_____ 0 A	: Current threshold for switching from absorption to Floating
Current	_____ 60 A	: Nominal charger output current

** Within charger rating range.

3.3.2.9 Saving

Press the Save button to confirm your choice of batteries, Boost and Refresh.



3.3.3 Advance settings

All these parameters are not volatile. They remain unchanged despite the absence of charger power. It can take up to 30 seconds for a change to take effect.

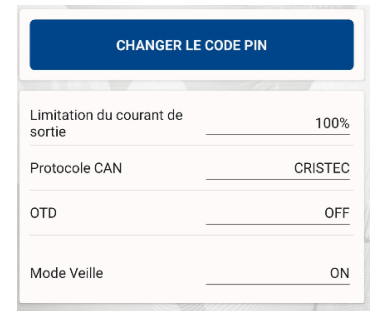

3.3.3.1 Pin code change

The default pin code can be changed by pressing:
You will then need to choose a 6-digit sequence.



If you forget, you can always reset the code to 000000 by simultaneously pressing the charger's two PUSH buttons for 3 seconds.

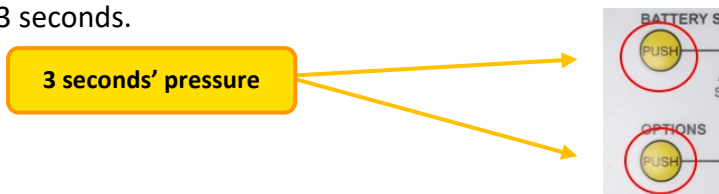

3.3.3.2 Output current limiting

Current can be limited in 10% steps relative to the charger rating.

3.3.3.3 BUSCAN protocol selection

YPOWER+ Battery chargers can communicate with the following CANBUS protocols:

Protocol
CRISTEC
Multibloc
PBUS

3.3.3.4 OTD

Activate or deactivate OTD function, see OTD function (Over the Temperature Device) (see 3.4.2).

3.3.3.5 Standby mode

Activate or deactivate the standby function, see standby function (see 3.4.3).

3.3.4 CANBUS

YPOWER+ Chargers (excluding OEPL series) are fitted with two sockets compatible with Molex Microfit 3.0, 6-pin connectors, part no. 43045-0600.

Bus-CAN documentation (hardware and software specifications) is available on request from CRISTEC.

Protocol

The CANBUS protocol can be selected using the CRISTEC CONNECT application (see 3.3.3).

CANBUS SUPPLY

BUS-CAN power must be supplied by other equipment, not by the charger itself.

Communication

Several equipments can be daisy chained on a CAN bus.

To enable communication between several devices, each entity must have a unique identifier (ID). This ID must be selected using the 4 microswitches (1,2,3,4) available on the connection side.

Within a single CAN network, 4 sub-networks (A, B, C, D) can be defined. This means that only the 4 sub-network entities can communicate with each other. For example: Master A and Slaves A1, A2 & A3.



Switches settings				ID	Master/Slave function	Sub-network
1	2	3	4	N°		
0	0	0	0	0	Master A	A
1	0	0	0	1	Master B	B
0	1	0	0	2	Master C	C
1	0	0	0	3	Master D	D
Factory settings (by default):				4	Slave A1	A
0	0	1	0	5	Slave B1	B
1	0	1	0	6	Slave C1	C
0	1	1	0	7	Slave D1	D
1	1	1	0	8	Slave A2	A
0	0	0	1	9	Slave B2	B
1	0	0	1	10	Slave C2	C
0	1	0	1	11	Slave D2	D
1	1	0	1	12	Slave A3	A
0	0	1	1	13	Slave B3	B
1	0	1	1	14	Slave C3	C
0	1	1	1	15	Slave D3	D

3.4 OPTIONS AND FEATURES

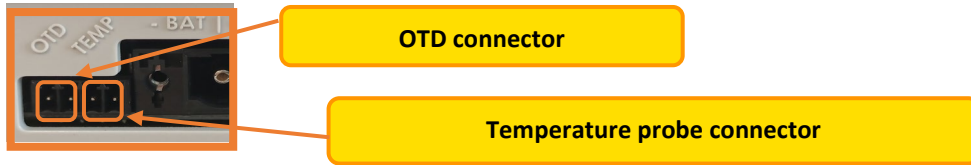

3.4.1 Compensation temperature probe (optional)

STP-UNI-2.8 (2.8 meters long) and STP-UNI-5.0 (5 meters long) temperature probes enable the compensation of Absorption voltage and Floating voltage depending on the ambient temperature of the battery room.

The coefficient used is $-18\text{mV}/^{\circ}\text{C}$ for 12V models and $-36\text{mV}/^{\circ}\text{C}$ for 24V models.



Temperature is not compensated when Wintering (or standby sealed bat), Stabilized DC power supply or Lithium iron phosphate (LiFePO₄) with BMS settings are selected.

3.4.2 OTD (optional)

YPOWER+ chargers are equipped with an OTD (over-temperature protection device) sensor input. This digital input stops the charging process and triggers an alarm if it remains open. This feature complies with safety requirements such as hydrogen detection.

This input can be used as a remote ON/OFF using a dry contact.

3.4.3 Standby mode

This mode can only be activated by the Bluetooth application or the CAN-Bus.

Standby mode allows the charger to operate while the AC network is off. The aim is to monitor or configure the charger without power supply from the input network. In this mode, the chargers are powered by the batteries connected to the output.

The charger switches off if the output voltage drops below 9.9V (for 12V batteries) or 19.8V (for 24V batteries).

If the charger is not used for more than 4 weeks in this standby mode, disconnect all the batteries connected to the charger in order to avoid any discharge due to continuous consumption.

Voltage	typical
12V	3.7mA
24V	3.7mA

3.5 FACTORY SETTINGS

The charger is configured ex-factory as a **sealed lead-/ AGM/ GEL battery, BOOST ON, REFRESH OFF, STANDBY OFF.**

This configuration is a compromise for satisfactory recharging of different battery technologies:

- Classic open lead
- Sealed, Gel or AGM
- Sealed spiral
- Lithium iron phosphate (LiFePO₄) with BMS

To fine-tune charging, refer to the table in paragraph 3.3.1.1.

In the case of special batteries, please refer to a professional installer, who will make special adjustments in accordance with the battery manufacturer's specifications and taking into account the particularities of the installation.

CRISTEC declines all responsibility for damage to batteries or incorrect recharging.

3.6 CHARGING CURVE

The charger's charge status is indicated by one of the green charge status LEDs

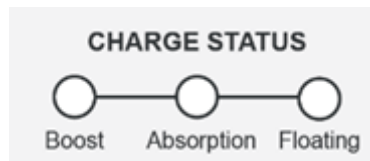

3.6.1 BOOST and REFRESH in ON position

With this setting, the **YPOWER+** charger delivers a 5-step charge curve IUoU + automatic weekly recycling BOOST: BOOST, ABSORPTION, FLOATING + REFRESH, REBOOST.

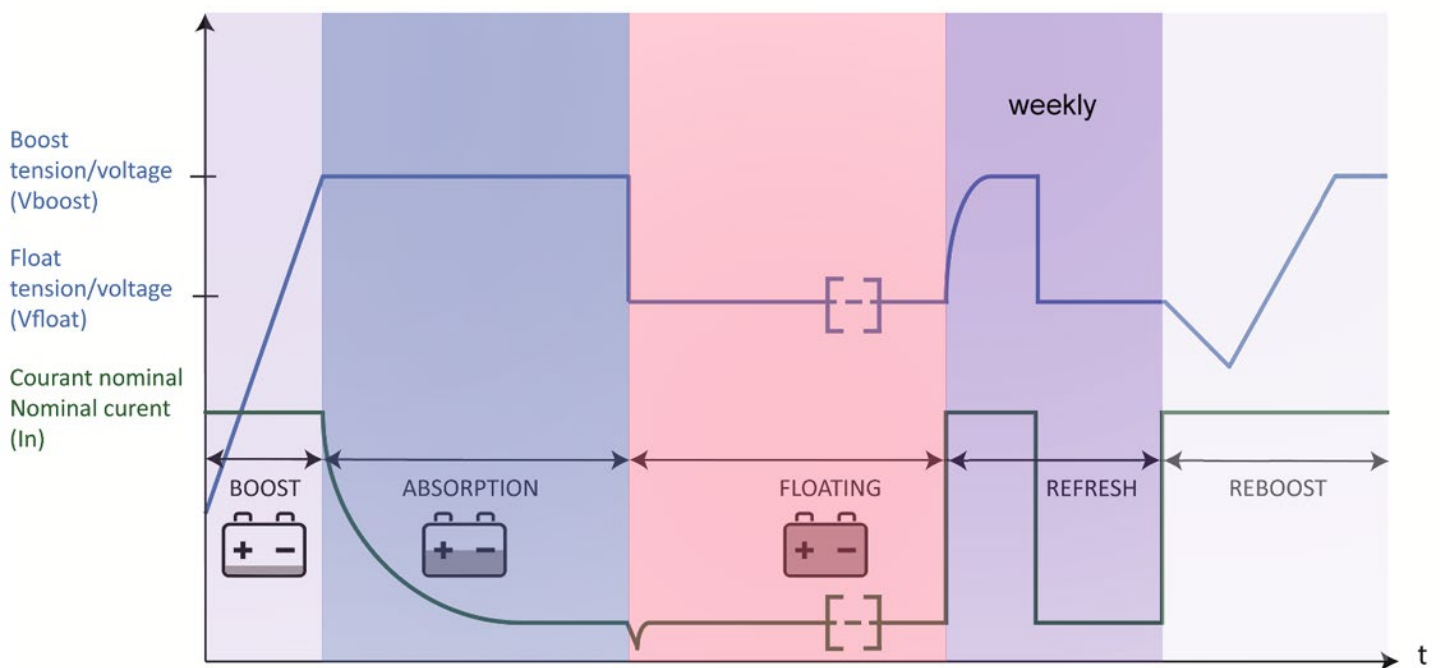

5-step charge curve IUoU with automatic weekly refresh

- V BOOST: BOOST voltage (see section 3.3.3.1)
- V FLOAT: FLOATING voltage (see section 3.3.3.1: voltage with no BOOST)
- T BOOST: BOOST maximum duration (see table above – paragraph 3.3.3.1)
- T ABS: ABSORPTION maximum duration (see table above – paragraph 3.3.3.1)

BOOST phase:

Starts up automatically when the charger is turned on if the battery is flat. The current is then at maximum output.

ABSORPTION phase:

Starts when the voltage has reached the maximum BOOST level. The current level starts falling.

These two phases combined last a maximum of TBOOST+TABS (depending on setting). If the current falls below 20% of rated current, the FLOATING phase automatically kicks in. Duration and current intensity depend on how charged the battery is.

FLOATING phase:

Starts after TBOOST or if output current has reached 20% of the charger's rated current. The voltage switches to the FLOATING value and the rated current continues to drop.

REFRESH phase:

It is an automatic weekly cycle in order to optimize the battery life duration.

It will occur only after a complete recharge cycle (BOOST, ABSORPTION and FLOATING). The charger will generate automatically a safe timed voltage step every 7 days even if REFRESH phase is off (see section 3.3.1.2)

Phase REBOOST:

Automatic phase consisting in coming back to a BOOST voltage if the DC utilizations require it (i.e., after a complete recharge cycle BOOST, ABSORPTION and FLOATING if some DC constant consumptions are detected the charger will restart a new complete charge cycle including a BOOST phase).

This REBOOST phase will be authorized after measuring certain battery voltage during a determined time.

3.6.2 BOOST and REFRESH in OFF position





















With this setting, the **YPOWER+** charger produces a single-stage UI type charge curve. It generates a constant voltage VFloat, supplying the current required by the battery(ies). Recharging time depends on the state of the battery, being longer than when the BOOST is in the ON position (see section 3.3.1.2 and 3.3.2.7).

3.6.3 BOOST in ON and REFRESH in OFF position

With this setting, the **YPOWER+** charger delivers the same charge curve IUoU as in chapter 3.6.1 but without the REFRESH step.

3.7 INDICATORS

The following LED indicators are visible on the front of the appliance to show the status of the charger.

Led	Mode	LED status	Charger status
LED "ON" 	charging		Charger is ON
			Mode stand-by (see section 3.4.3)
	default	 (off)	No or poor-quality AC current Input fuse is blown Internal charger malfunction
LED ALARM	default		 OTD fault  Output fuse blown  temperature range  No output voltage
			Other faults
LEDS OPTIONS	Boost		Boost activated
	Refresh		Refresh activated
LEDS BATTERY SELECOR	AGM-GEL...		Battery type: AGM/Gel/ Sealed Lead
	Wet lead		Battery type: Wet lead
	Lithium		Battery type: Lithium
	Custom		Custom mode
LEDS CHARGE STATUS	-		Charger in BOOST phase
			Charger in ABSORPTION phase
			Charger in FLOATING phase
			Charger in REFRESH phase
		 (off)	Output voltage OFF

When the charger saves a new configuration, the status LEDs light up one after the other to indicate that the configuration has been saved.

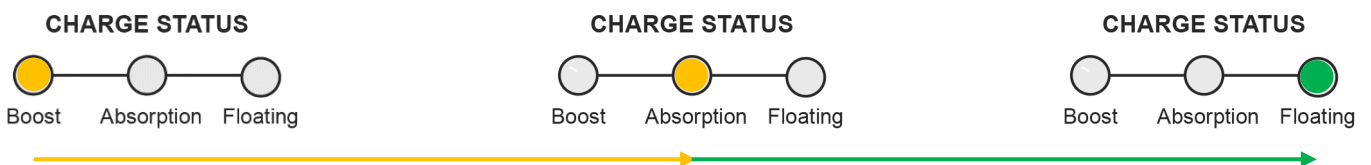

3.8 THERMAL PERFORMANCE

The curve below shows the charger's current limitation as a function of ambient temperature, model of charger and mains voltage: $V_e=230VAC$ or $V_e=115VAC$.

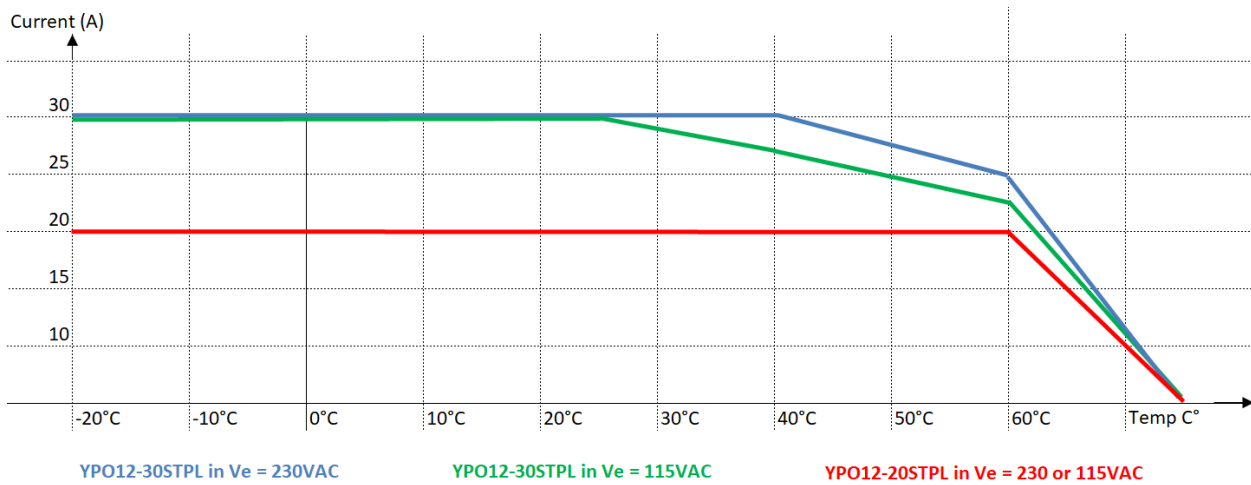

The YPO24-15STPL follows the same curves as the YPO12-30STPL but shifted down by 15A on the y-axis.

4 EQUIPMENT MAINTENANCE AND REPAIRS

4.1 OVERVIEW

This paragraph deals with equipment maintenance and repairs. Proper operation of the product and its service life are dependent on strict compliance with the following recommendations.

4.2 EQUIPMENT MAINTENANCE

Disconnect the battery charger from the AC network and the batteries before starting any maintenance work.

If appliances are in a dusty atmosphere, vacuum-clean them regularly, since dust deposits may adversely affect heat dissipation.

Check the state of battery charge every 3 months.

Nuts and screws should be tightened annually to ensure efficient operation of the appliance (particularly in rugged conditions: vibrations, shocks, high variations in temperature etc.).

4.3 EQUIPMENT REPAIRS

Disconnect the battery charger from the AC power network and disconnect the batteries before undertaking any repairs.

When fuses have blown, only use fuses of the type and size recommended in this manual.

Please contact CRISTEC or their distributor for any other repairs.

Any repair without CRISTEC prior agreement entails an exclusion of warranty.

YPOWER+ 12V-20A, 12V-30A, 24V-15A

Part Number	YPO12-20STPL/(OEPL)	YPO12-30STPL/(OEPL)	YPO24-15STPL/(OEPL)
Model	12V/20A	12V/30A	24V/15A
Recommended battery bank*	100-200Ah	200-300Ah	100-200Ah
Input			
Voltage	from 90 to 265VAC single-phase automatic		
Frequency	from 47 to 65Hz automatic		
Input current consumption 230/115VAC	1,3/2,6A	2/4A	2/4A
Recommended power for a generator	450W	650W	650W
Power factor	1		
Efficiency	92.8% in 240V and 91% in 120VAC		
Input fuses	T6.3A/250V - SCHURTER Ref. 0001.1032		
Output			
Number of battery banks	3 separate positive terminals: +BAT E, +BAT 1 et +BAT 2 (integrated Mosfet splitter) 1 -BAT negative terminal Each bank can be used individually and delivers the rated current		
Nominal current (+/-7%) / Rated Power	20A/276W	30A/414W	15A/414W
Charging curve	IU or IUoU through internal push-button, Bluetooth or CAN-Bus (Boost, Absorption, Floating and Refresh)		
Battery type	Lead sealed, Gel, AGM as factory setting , calcium lead, LiFePO4, DC power-supply mode, etc. Specific request on demand		
Boost voltage	14.4VDC for lead sealed battery (factory setting)	28.8VDC for lead sealed battery (factory setting)	
Floating voltage	13.8VDC for lead sealed battery (factory setting)	27.6VDC for lead sealed battery (factory setting)	
Peak to peak ripple and noise	< 2% (at rated conditions)		
Automotive output fuse mounted in series in minus pole -BAT	1 x 30A/32V	2 x 30A/32V	1 x 20A/32V
Environment			
Cooling	Fanless		
Sound level	0 dB		
Operating temperature at 230VAC	From -20°C to +60°C (-4°F to 140°F) , derating above 40°C (104°F). See chapter 3.8		
Storage temperature	From -20°C to +70°C (-4°F to 158°F)		
Relative humidity	up to 70% (95% without condensation)		
Casing			
Material	Casing comprises 3 parts: Aluminium sink frame / Thermoplastic body / Aluminium clasp		
Dimensions (length, height, depth) / Weight	238 x 180 x 81 mm (9.4 x 7.1 x 3.2 in) / 1,9kg (2.2 lb)		
Fixing centre distance	219 x 155 mm (8.6 x 6.1 in)		
Fixing screw (wall)	4 x M5 round head screws		
Protection factor	IP22		
Standards			
CE declaration of conformity	Available on request		
CE / EMC MARK	EN61204-3		
CE / Security MARK	EN60335-2-29, ISO8846		
Protections			
	<ul style="list-style-type: none"> - Against transient input overvoltage by varistor (out of warranty) - Against output polarity inversions by fuse - Against short-circuits and output overloads - Against abnormal overheating 		
Communication			
	CANBUS (according to models) / Bluetooth as standard (optional on OE version) Bluetooth BLE +9dBm (2412-2484Mhz)		
Options			
	Temperature probe / Bluetooth dongle (OE versions)/OTD probe/Remote switch		

*Recommended battery capacity for lead type batteries, ratio C/10. Consult us for lithium batteries capacity

6 SAFETY WARNINGS AND CONDITIONS OF WARRANTY

6.1 PRECAUTIONS (WARNING) – PROVISIONS RELATING TO SAFETY

Material class I according to NF EN 60335-2-29 : 12-2024 standards.

The requirements for installation are contained in the NFC 15-100 standards and in the specific standard “for small crafts – electrical systems– Alternating and direct current installations” ISO13297 reference.

The installation must be carried out by an electrician or a professional installer.

It is essential not to install, repair, start any maintenance or cleaning on this device under voltage. All energy sources must be turned off. The batteries must be isolated by the battery disconnect switches according to the standard. Chargers, alternators, or other energy-generating devices must be turned off, or isolated.

This appliance is not intended for use by persons (including children) with reduced physical, sensory or mental capabilities, or lack of experience and knowledge, unless they have been given supervision or instruction concerning use of the appliance by a person responsible for their safety.

Children should be supervised to ensure that they do not play with the appliance.

Main precaution

Before handling the charger, please read carefully this manual.



Precautions regarding electric shocks

Risk of electric shock and danger of death: it's strictly forbidden to open the charger under voltage.



Precautions regarding accidental earth leaks

The charger's Protection Earth Terminal (PE) must be earthed and connected before any other terminal.

Accidental leakage current between phase and earth:

standard NFC15-100 should be followed when installing.

The charger has to be connected to a 30mA differential Ground Fault Circuit following standard NFC15-100 recommendation.

Accidental leakage current between the charge circuit and the earth:

accidental current leakage at the earth must be detected by means of an independent protective device outside the charger (a residual current device or an insulation detector).

The installer should decide on the rating and nature of the protection according to the risks.

Special precautions should be taken on any installation prone to electrolyze phenomena. Electrical standard requires a battery switch as close as possible to the batteries.



Precautions regarding lightning

In highly exposed geographical areas, it may be useful to install a lightning arrester upstream of the charger to prevent irreversible damage.



Precautions regarding overheating of the appliance

The equipment is designed to be mounted on a vertical wall as described in this manual.

It is imperative to maintain a 150mm clearance around the charger. The installer will take the necessary steps to ensure that the air temperature is below 65°C around the charger.

The necessary measures will also be taken to allow hot air to escape on either side of the charger.

It is strictly forbidden to place any object on or against the charger.

The charger must not be installed near a heat source. It must be installed in a ventilated area.

The charger's air inlets and outlets must not be obstructed.



Attention hot surface: do not touch the charger during and after its operation (burn hazard).



Measures to prevent dust, run-off and waterfalls

The location of the charger must be chosen to avoid any moisture, liquid, salt or dust entering the charger.

These incidents could cause irreversible damage to the equipment and potentially endanger the user. The charger should be positioned in a dry, well-ventilated area.



Precautions regarding inflammable materials

The charger must not be used near flammable liquids or gases. Batteries are liable to emit explosive gases: when installing batteries, follow the manufacturer's instructions.

Near batteries: ventilate the area, do not smoke, do not use naked flames.



Fuses and ignition protection (protection against flammable gases).

The battery chargers are protected against ignition of surrounding flammable gases according to ISO 8846 standard.

DC output fuses should only be replaced with the appropriate ignition protection fuse:

Label and quantity: *see section 5*

Manufacturer: Bussmann / EATON

References: ATM 20 /ATM30 /ATM15



Other precautions

Never attempt to drill or to machine the charger's case: this may damage components or cause metal chips or filings to fall on the charger's board.

Do not do anything that is not explicitly stated in this manual.

6.2 WARRANTY

Failure to comply with the installation and use rules voids the manufacturer's warranty and releases CRISTEC from any liability

The warranty is valid for 36 months.

The warranty applies if the cause of the failure is an internal defect in the charger that falls to CRISTEC.

The warranty applies for equipment returned to the Chateaulin plant (France).

The warranty, if confirmed by the expert's report, covers only:

- The repair (part(s) and labour) of faulty equipment returned to the CHATEAULIN plant (France). Only original parts recognized as being defective will be replaced under the warranty.
- Return shipping costs after repair (courier, by a carrier of our choice).

The warranty, if confirmed by the expert's report, gives rise only to a repair of the equipment and not to a replacement of the equipment.

The warranty does not cover any other costs that may have been caused by the malfunction of the equipment, such as: shipping and packaging, disassembly, reassembly and testing costs, as well as all other costs not mentioned.

Our warranty on no account provides for any form of compensation. CRISTEC shall not be held liable for damage incurred as a result of using the charger.

The warranty does not apply if the origin of the failure is due to an external default (see below). In this case, a repair estimate will be issued.

Our warranty does not cover:

1. Non-compliance with this manual
2. Any modification and mechanical, electrical or electronic intervention on the device
3. Improper use
4. Presence of moisture
5. Failure to comply with AC power-supply tolerances (i.e., overvoltage)
6. Incorrect connections
7. Falls or impacts during transportation, installation or use
8. Repairs carried out by anyone unauthorized by CRISTEC
9. The maintenance in the energy conversion area made by a non-authorized person by CRISTEC
10. Connection of any interface not supplied by CRISTEC
11. The cost of packaging and carriage
12. Apparent or latent damage sustained during shipment and/or handling (any such claims should be sent to the hauler)
13. Any unjustified return of equipment (no failure on the equipment)
14. Any other causes not listed above