

p70 / p70R



Installation and operation instructions

English

Date: 02-2014

Document number: 81355-1-EN

© 2014 Raymarine UK Limited

Trademark and patents notice

Autohelm, hsb², RayTech Navigator, Sail Pilot, SeaTalk, SeaTalk^{NG}, SeaTalk^{HS} and Sportpilot are registered trademarks of Raymarine UK Limited. RayTalk, Seahawk, Smartpilot, Pathfinder and Raymarine are registered trademarks of Raymarine Holdings Limited.

FLIR is a registered trademark of FLIR Systems, Inc. and/or its subsidiaries.

All other trademarks, trade names, or company names referenced herein are used for identification only and are the property of their respective owners.

This product is protected by patents, design patents, patents pending, or design patents pending.

Fair Use Statement

You may print no more than three copies of this manual for your own use. You may not make any further copies or distribute or use the manual in any other way including without limitation exploiting the manual commercially or giving or selling copies to third parties.

Software updates

Check the website www.raymarine.com for the latest software releases for your product.

Product handbooks

<p>The latest versions of all English and translated handbooks are available to download in PDF format from the website www.raymarine.com. Please check the website to ensure you have the latest handbooks.</p>

Copyright ©2014 Raymarine UK Ltd. All rights reserved.

Contents

Chapter 1 Important information.....	7	7.5 Powering the pilot controller on	40
TFT Displays	7	7.6 Using the set-up wizard	40
Water ingress	7	7.7 Using the Dockside wizard.....	41
Disclaimer	7	7.8 Adjusting the hard-over time	42
EMC installation guidelines	7	7.9 Compass linearization	42
Connections to other equipment	8	7.10 Compass lock	43
Declaration of conformity.....	8		
Product disposal.....	8	Chapter 8 Commissioning - SPX and	
Warranty registration.....	8	SmartPilot systems	45
IMO and SOLAS.....	8	8.1 SPX and SmartPilot autopilot installation	46
Technical accuracy	8	8.2 Pilot response	46
		8.3 Initial setup and commissioning.....	47
Chapter 2 Document and product		8.4 Powering the pilot controller on	47
information.....	9	8.5 Using the set-up wizard	48
2.1 Document information	10	8.6 Dockside calibration	48
2.2 Product overview	11	8.7 Dealer settings.....	49
		8.8 Adjusting the hard-over time	50
Chapter 3 Planning the installation	13	8.9 Sea trial calibration.....	50
3.1 Installation checklist	14	8.10 Checking autopilot operation.....	51
3.2 Pack contents	14		
3.3 p70 and p70R system integration	15	Chapter 9 Pilot modes.....	53
3.4 Compatible autopilot systems	16	9.1 Standby.....	54
3.5 Software updates	16	9.2 Auto	54
3.6 Tools	17	9.3 Mode menu	55
3.7 Typical systems	17	9.4 Patterns.....	55
3.8 System protocols	18	9.5 Track mode	56
3.9 Warnings and cautions	19	9.6 Wind vane mode (Sailing boats only).....	58
3.10 General location requirements	19	9.7 Power steer	60
3.11 Unit dimensions.....	20	9.8 Jog steer (tiller pilots only)	60
3.12 Before using your pilot controller	21	9.9 Shortcut key	61
Chapter 4 Cables and connections.....	23	Chapter 10 Pilot views	63
4.1 General cabling guidance	24	10.1 Available pilot views	64
4.2 Connections overview	24	10.2 Graphical view	64
4.3 Power connection	25	10.3 Large view	65
4.4 SeaTalk ^{ng} connection	26	10.4 Standard view	65
4.5 SeaTalk connection	27	10.5 Multiple view	66
		10.6 2D View.....	66
Chapter 5 Mounting.....	29	10.7 Setting the pilot view.....	67
5.1 Mounting	30	10.8 Setting up data boxes.....	67
Chapter 6 Getting started	31	Chapter 11 Pilot controller alarms	69
6.1 Pilot functions	32	11.1 Alarms	70
6.2 Pilot controls.....	32		
6.3 Instrument power	33	Chapter 12 Set up menu options	73
6.4 Display settings.....	34	12.1 Set up menu	74
6.5 Multiple data sources (MDS).....	35	12.2 Autopilot calibration menu.....	74
		12.3 System set-up menu.....	81
Chapter 7 Commissioning - Evolution		12.4 User preferences menu	82
autopilot system.....	37	12.5 Simulator	83
7.1 Evolution autopilot installation	38	12.6 Factory reset.....	83
7.2 Autopilot commissioning — main differences		12.7 Diagnostics	84
between Evolution and SPX systems	38		
7.3 Autopilot response levels	39	Chapter 13 Troubleshooting.....	85
7.4 Initial setup and commissioning.....	39		

13.1 Troubleshooting	86
Chapter 14 Maintenance	91
14.1 Routine equipment checks	92
14.2 Cleaning	92
14.3 Cleaning the display screen	93
14.4 Cleaning the display case	93
14.5 Cleaning the sun cover	94
Chapter 15 Technical support	95
15.1 Raymarine customer support	96
15.2 Viewing product information	96
Chapter 16 Technical specification.....	97
16.1 Viewing angle	98
16.2 Technical specification	98
Chapter 17 Spares and accessories	99
17.1 Spares and accessories.....	100
17.2 SeaTalk ^{ng} cabling components	100
17.3 SeaTalk ^{ng} cables and accessories	101
17.4 SeaTalk accessories.....	102

Chapter 1: Important information



Warning: Autopilot system Installation

As correct performance of the vessel's steering is critical for safety, we STRONGLY RECOMMEND that an Authorized Raymarine Service Representative fits this product. You will only receive full warranty benefits if you can show that an Authorized Raymarine Service Representative has installed and commissioned this product.



Warning: Product installation and operation

This product must be installed and operated in accordance with the instructions provided. Failure to do so could result in personal injury, damage to your vessel and/or poor product performance.



Warning: Maintain a permanent watch

Always maintain a permanent watch, this will allow you to respond to situations as they develop. Failure to maintain a permanent watch puts yourself, your vessel and others at serious risk of harm.



Warning: Ensure safe navigation

This product is intended only as an aid to navigation and must never be used in preference to sound navigational judgment. Only official government charts and notices to mariners contain all the current information needed for safe navigation, and the captain is responsible for their prudent use. It is the user's responsibility to use official government charts, notices to mariners, caution and proper navigational skill when operating this or any other Raymarine product.



Warning: Product grounding

Before applying power to this product, ensure it has been correctly grounded, in accordance with the instructions in this guide.



Warning: Positive ground systems

Do not connect this unit to a system which has positive grounding.



Warning: Power supply voltage

Connecting this product to a voltage supply greater than the specified maximum rating may cause permanent damage to the unit. Refer to the *Technical specification* section for voltage rating.



Warning: Switch off power supply

Ensure the vessel's power supply is switched OFF before starting to install this product. Do NOT connect or disconnect equipment with the power switched on, unless instructed in this document.

Caution: Power supply protection

When installing this product ensure the power source is adequately protected by means of a suitably-rated fuse or automatic circuit breaker.



Warning: Ensure all equipment has isolated power supply

This product features an isolated power supply. To prevent potential damage to equipment, Raymarine recommends that any external equipment connected to this product also features an isolated power supply.

TFT Displays

The colors of the display may seem to vary when viewed against a colored background or in colored light. This is a perfectly normal effect that can be seen with all color Thin Film Transistor (TFT) displays.

Caution: Service and maintenance

This product contains no user serviceable components. Please refer all maintenance and repair to authorized Raymarine dealers. Unauthorized repair may affect your warranty.

Water ingress

Water ingress disclaimer

Although the waterproof rating capacity of this product meets the stated IPX standard (refer to the product's *Technical Specification*), water intrusion and subsequent equipment failure may occur if the product is subjected to commercial high-pressure washing. Raymarine will not warrant products subjected to high-pressure washing.

Disclaimer

Raymarine does not warrant that this product is error-free or that it is compatible with products manufactured by any person or entity other than Raymarine.

Raymarine is not responsible for damages or injuries caused by your use or inability to use the product, by the interaction of the product with products manufactured by others, or by errors in information utilized by the product supplied by third parties.

EMC installation guidelines

Raymarine equipment and accessories conform to the appropriate Electromagnetic Compatibility (EMC) regulations, to minimize electromagnetic interference between equipment and minimize the effect such interference could have on the performance of your system

Correct installation is required to ensure that EMC performance is not compromised.

For **optimum** EMC performance we recommend that wherever possible:

- Raymarine equipment and cables connected to it are:
 - At least 1 m (3 ft) from any equipment transmitting or cables carrying radio signals e.g. VHF radios, cables and antennas. In the case of SSB radios, the distance should be increased to 7 ft (2 m).
 - More than 2 m (7 ft) from the path of a radar beam. A radar beam can normally be assumed to spread 20 degrees above and below the radiating element.
- The product is supplied from a separate battery from that used for engine start. This is important to prevent erratic behavior and data loss which can occur if the engine start does not have a separate battery.
- Raymarine specified cables are used.
- Cables are not cut or extended, unless doing so is detailed in the installation manual.

Note: Where constraints on the installation prevent any of the above recommendations, always ensure the maximum possible separation between different items of electrical equipment, to provide the best conditions for EMC performance throughout the installation

Connections to other equipment

Requirement for ferrites on non-Raymarine cables

If your Raymarine equipment is to be connected to other equipment using a cable not supplied by Raymarine, a suppression ferrite **MUST** always be attached to the cable near the Raymarine unit.

Declaration of conformity

Raymarine UK Ltd. declares that this product is compliant with the essential requirements of EMC directive 2004/108/EC.

The original Declaration of Conformity certificate may be viewed on the relevant product page at www.raymarine.com.

Product disposal

Dispose of this product in accordance with the WEEE Directive.



The Waste Electrical and Electronic Equipment (WEEE) Directive requires the recycling of waste electrical and electronic equipment. Whilst the WEEE Directive does not apply to some Raymarine products, we support its policy and ask you to be aware of how to dispose of this product.

Warranty registration

To register your Raymarine product ownership, please visit www.raymarine.com and register online.

It is important that you register your product to receive full warranty benefits. Your unit package includes a bar code label indicating the serial number of the unit. You will need this serial number when registering your product online. You should retain the label for future reference.

IMO and SOLAS

The equipment described within this document is intended for use on leisure marine boats and workboats NOT covered by International Maritime Organization (IMO) and Safety of Life at Sea (SOLAS) Carriage Regulations.

Technical accuracy

To the best of our knowledge, the information in this document was correct at the time it was produced. However, Raymarine cannot accept liability for any inaccuracies or omissions it may contain. In addition, our policy of continuous product improvement may change specifications without notice. As a result, Raymarine cannot accept liability for any differences between the product and this document. Please check the Raymarine website (www.raymarine.com) to ensure you have the most up-to-date version(s) of the documentation for your product.

Chapter 2: Document and product information

Chapter contents

- [2.1 Document information on page 10](#)
- [2.2 Product overview on page 11](#)

2.1 Document information

This document contains important information related to the installation of your Raymarine product.



The document includes information to help you:

- plan your installation and ensure you have all the necessary equipment;
- install and connect your product as part of a wider system of connected marine electronics;
- troubleshoot problems and obtain technical support if required.

This and other Raymarine product documents are available to download in PDF format from www.raymarine.com.

Applicable products

This document is applicable to the following products:

	Part number	Name	Description
	E22166	p70	SeaTalk [®] 8 button pilot control head (Sail)
	E22167	p70R	SeaTalk [®] Rotary pilot control head (Power)

Document conventions

The following conventions are used throughout this document when referring to:

Type	Example	Convention
Procedures for performing specific tasks using a multifunction display.	Select Transducer Set-Up .	The term "Select" is used to refer to the action of selecting a menu option on a multifunction display, using the touchscreen or physical controls, depending on display variant.
Procedures for navigating menu hierarchies on a multifunction display.	Internal sonar module is turned off from the Fishfinder application menu: Menu > Set-up > Sounder Set-up > Internal Sounder .	Menu hierarchies are used in this document to provide a quick summary on how to access a particular function on the multifunction display.

Document illustrations

Your product may differ slightly from that shown in the illustrations in this document, depending on product variant and date of manufacture.

All images are provided for illustration purposes only.

Product documentation

The following documentation is applicable to your product:

Description	Part number
p70 / p70R Installation instructions	88031
p70 / p70R Installation and operation instructions	81355
p70 / p70R Mounting template	87130

Additional handbooks

Description	Part number
SeaTalk [®] reference manual	81300
SeaTalk to SeaTalk [®] converter	87121

2.2 Product overview

The p70 and p70R are SeaTalk^{ng} autopilot controllers.

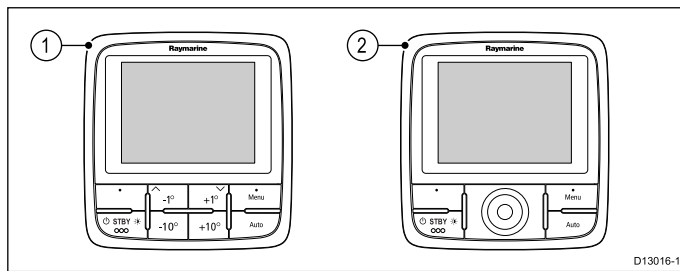

1. p70 (8 button pilot control head)
2. p70R (Rotary pilot control head)

The unit has the following features:

- 2 x SeaTalk^{ng} connections
- Compatible with NMEA 2000 and SeaTalk standards.
- 12 V dc operation.
- Waterproof to IPX 6.

Chapter 3: Planning the installation

Chapter contents

- [3.1 Installation checklist on page 14](#)
- [3.2 Pack contents on page 14](#)
- [3.3 p70 and p70R system integration on page 15](#)
- [3.4 Compatible autopilot systems on page 16](#)
- [3.5 Software updates on page 16](#)
- [3.6 Tools on page 17](#)
- [3.7 Typical systems on page 17](#)
- [3.8 System protocols on page 18](#)
- [3.9 Warnings and cautions on page 19](#)
- [3.10 General location requirements on page 19](#)
- [3.11 Unit dimensions on page 20](#)
- [3.12 Before using your pilot controller on page 21](#)

3.1 Installation checklist

Installation includes the following activities:

Installation Task	
1	Plan your system.
2	Obtain all required equipment and tools.
3	Site all equipment.
4	Route all cables.
5	Drill cable and mounting holes.
6	Make all connections into equipment.
7	Secure all equipment in place.
8	Power on and test the system.

Schematic diagram

A schematic diagram is an essential part of planning any installation. It is also useful for any future additions or maintenance of the system. The diagram should include:

- Location of all components.
- Connectors, cable types, routes and lengths.

3.2 Pack contents

All models contain the following items:

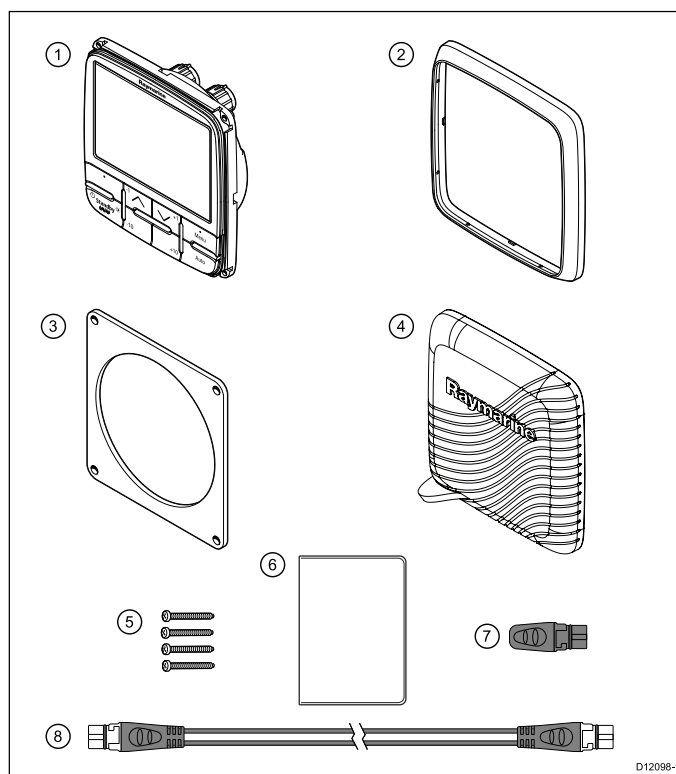

Number	Description
1.	p70 / p70R Pilot controller (p70 8 button controller is shown in diagram above.)
2.	Bezel
3.	Gasket
4.	Suncover
5.	4 x fixing screws
6.	Document pack
7.	SeaTalk [®] Blanking plug
8.	SeaTalk [®] Spur Cable

Unpack the pilot controller unit carefully to prevent damage. Save the carton and packing in case the unit has to be returned for service.

3.3 p70 and p70R system integration

The p70 and p70R pilot controllers are used to control your autopilot system.

The diagram below illustrates external devices that can be connected to your unit.

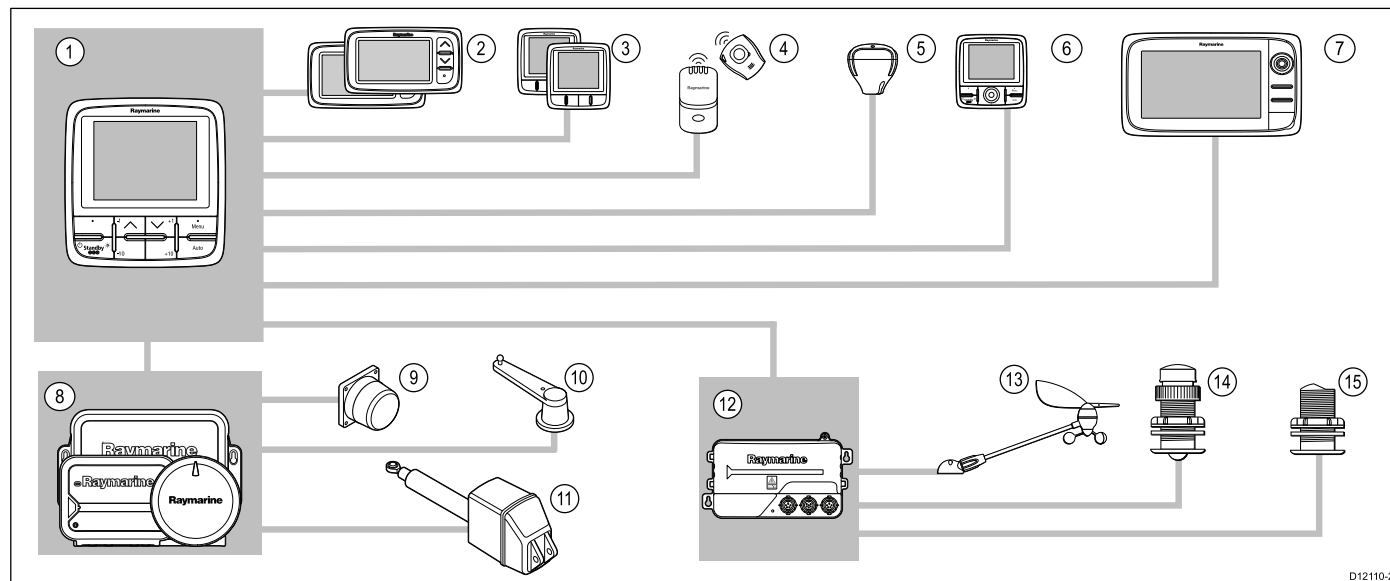

D12110-2

Item	Device type
1.	p70 / p70R
2.	SeaTalk Instruments
3.	SeaTalk ^{ng} Instruments
4.	MOB (via SeaTalk to SeaTalk ^{ng} converter.)
5.	SeaTalk ^{ng} GPS receiver
6.	SeaTalk ^{ng} Pilot controller
7.	Raymarine Multifunction displays
8.	Raymarine autopilots
9.	Fluxgate compass
10.	Rudder reference
11.	Drive unit
12.	iTC-5 converter
13.	Analogue wind transducers
14.	Analogue speed transducers
15.	Analogue depth transducers
Other devices not shown:	Smart transducers (e.g. DST800, DT800) NMEA 2000 devices (e.g. engine data, fuel management system)

3.4 Compatible autopilot systems

Your product is compatible with the Raymarine Autopilot systems shown below.

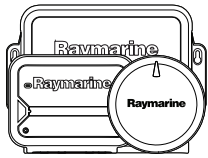
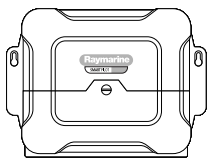
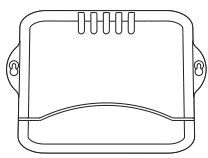
Product	Description	Connection
	Evolution autopilots	SeaTalk ^{ng}
	SPX SmartPilot	SeaTalk ^{ng}
	S1, S2 & S3 SmartPilot	SeaTalk via a SeaTalk to SeaTalk ^{ng} adaptor cable.

3.5 Software updates

The software running on the product can be updated.

- Raymarine periodically releases software updates to improve product performance and add new features.
- You can update the software for your product using a connected and compatible multifunction display.
- Refer to www.raymarine.com/software/ for the latest software updates and the software update procedure for your product.
- If in doubt as to the correct procedure for updating your product software, refer to your dealer or Raymarine technical support.

Caution: Downloading software updates

The software update process is carried out at your own risk. Before initiating the update process ensure you have backed up any important files.

Ensure that the unit has a reliable power supply and that the update process is not interrupted.

Damage caused by incomplete updates are not covered by Raymarine warranty.

By downloading the software update package, you agree to these terms.

3.6 Tools

Tools required for installation

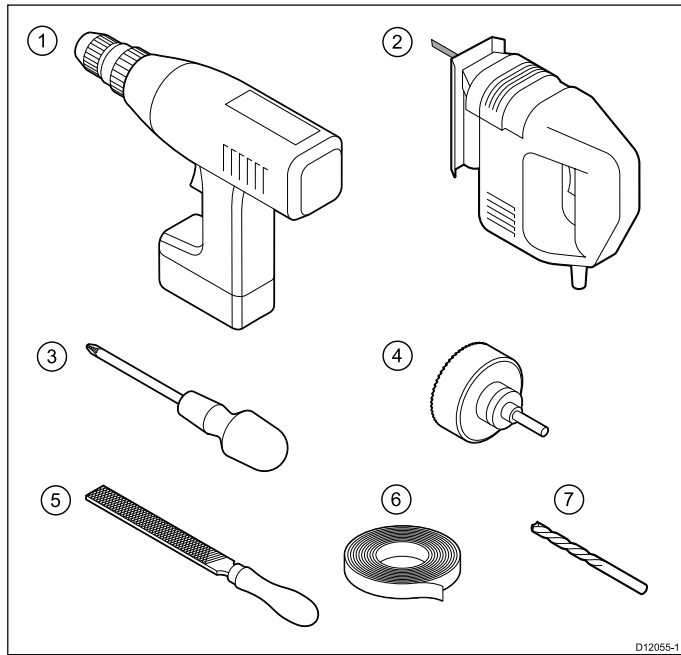

1.	Power drill
2.	Jig saw
3.	Screwdriver
4.	Suitable size (10 mm to 30 mm) hole cutter
5.	File
6.	Adhesive tape
7.	Drill bit of appropriate size*

Note: *Drill bit size is dependent on the thickness and type of material that the unit is to be mounted on.

3.7 Typical systems

Note: The information below is provided as examples of how to connect your unit to compatible autopilot systems. For detailed information on setting up an autopilot system please refer to the installation instructions that accompanied your system.

Example — Evolution system (SeaTalk^{ng})

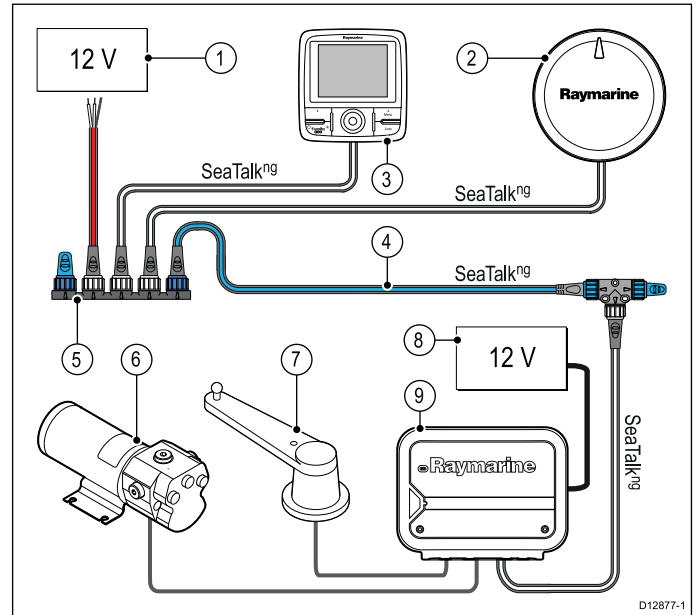

1. Power supply for SeaTalk^{ng}.
2. Evolution autopilot (EV-1 shown).
3. p70 / p70R pilot controller (p70R shown).
4. SeaTalk^{ng} backbone.
5. SeaTalk^{ng} 5-way connector.
6. Drive unit.
7. Rudder reference unit.
8. Power supply for ACU.
9. ACU (ACU-100 shown).

Note: The ACU-100 does not provide power to SeaTalk^{ng}. A separate 12 V power supply is required.

Example — SmartPilot SPX system (SeaTalk^{ng})

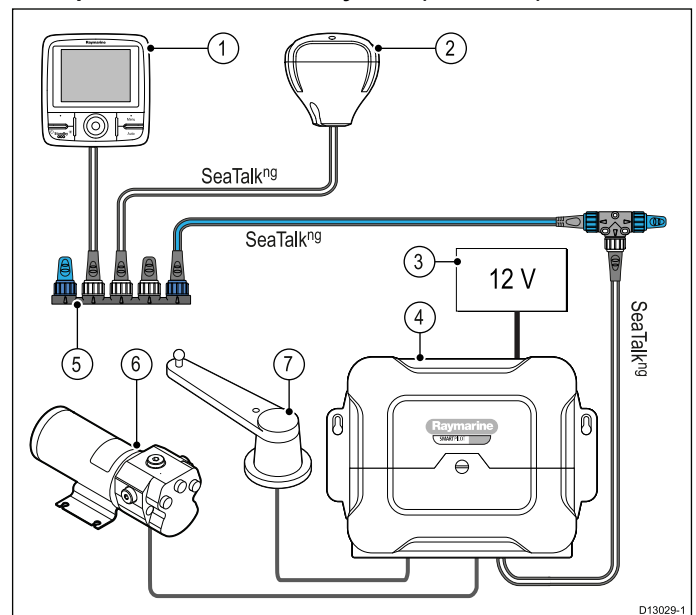

1. p70 / p70R pilot controller (p70R shown).
2. GPS Receiver.
3. 12 V dc power supply to SPX, also supplying power to SeaTalk^{ng}.

4. SPX SmartPilot.
5. SeaTalk^{ng} 5-way connector.
6. Drive unit.
7. Rudder reference unit.

Example — SmartPilot system (SeaTalk)

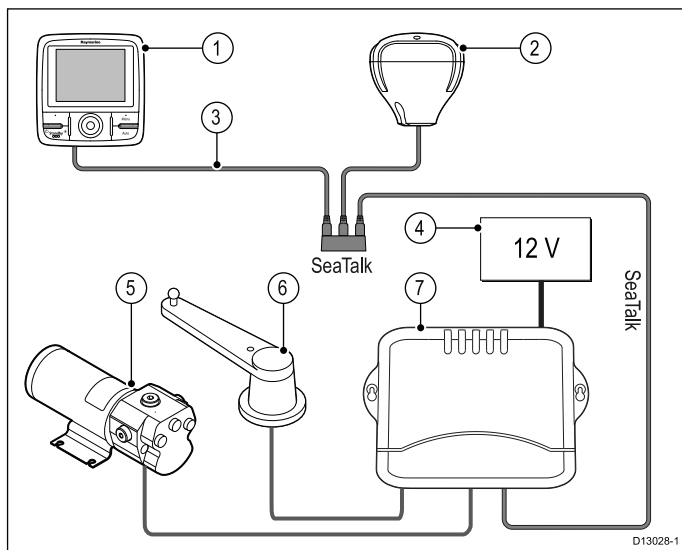

1. p70 / p70R pilot controller (p70R shown).
2. GPS Receiver.
3. SeaTalk to SeaTalk^{ng} adaptor cable.
4. 12 V dc power supply to the SmartPilot, also supplying power to SeaTalk.
5. Drive unit.
6. Rudder reference unit.
7. SmartPilot.

3.8 System protocols

Your product can be connected to various products and systems to share information and so improve the functionality of the overall system. These connections may be made using a number of different protocols. Fast and accurate data collection and transfer is achieved by using a combination of the following data protocols:

- SeaTalk^{ng}
- NMEA 2000
- SeaTalk

Note: You may find that your system does not use all of the connection types or instrumentation described in this section.

Seataalk^{ng}

SeaTalk^{ng} (Next Generation) is an enhanced protocol for connection of compatible marine instruments and equipment. It replaces the older SeaTalk and SeaTalk² protocols.

SeaTalk^{ng} utilizes a single backbone to which compatible instruments connect using a spur. Data and power are carried within the backbone. Devices that have a low draw can be powered from the network, although high current equipment will need to have a separate power connection.

SeaTalk^{ng} is a proprietary extension to NMEA 2000 and the proven CAN bus technology. Compatible NMEA 2000 and SeaTalk / SeaTalk² devices can also be connected using the appropriate interfaces or adaptor cables as required.

NMEA 2000

NMEA 2000 offers significant improvements over NMEA 0183, most notably in speed and connectivity. Up to 50 units can simultaneously transmit and receive on a single physical bus at any one time, with each node being physically addressable. The standard was specifically intended to allow for a whole network of marine electronics from any manufacturer to communicate on a common bus via standardized message types and formats.

SeaTalk

SeaTalk is a protocol which enables compatible instruments to connect to each other and share data.

The SeaTalk cable system is used to connect compatible instruments and equipment. The cable carries power and data and enables connection without the need for a central processor.

Additional instruments and functions can be added to a SeaTalk system, simply by plugging them into the network. SeaTalk equipment can also communicate with other non-SeaTalk equipment via the NMEA 0183 standard, provided a suitable interface is used.

3.9 Warnings and cautions

Important: Before proceeding, ensure that you have read and understood the warnings and cautions provided in the [Chapter 1 Important information](#) section of this document.

3.10 General location requirements

When selecting a location for your display it is important to consider a number of factors.

Key factors which can affect product performance are:

- **Ventilation**
To ensure adequate airflow:
 - Ensure that equipment is mounted in a compartment of suitable size.
 - Ensure that ventilation holes are not obstructed. Allow adequate separation of equipment.Any specific requirements for each system component are provided later in this chapter.
- **Mounting surface.**
Ensure equipment is adequately supported on a secure surface. Do not mount units or cut holes in places which may damage the structure of the vessel.
- **Cable entry**
Ensure the unit is mounted in a location which allows proper routing and connection of cables:
 - Minimum bend radius of 100 mm (3.94 in) unless otherwise stated.
 - Use cable supports to prevent stress on connectors.
- **Water ingress**
The display is suitable for mounting both above and below decks. It is waterproof to IPX6 standard. Although the unit is waterproof, it is good practice to locate it in a protected area away from prolonged and direct exposure to rain and salt spray.
- **Electrical interference**
Select a location that is far enough away from devices that may cause interference, such as motors, generators and radio transmitters/receivers.
- **Magnetic compass**
Select a location that is at least 3 ft (1 m) away from a magnetic compass.
- **Power supply**
Select a location that is as close as possible to the boat's DC power source. This will help to keep cable runs to a minimum

Site Requirements

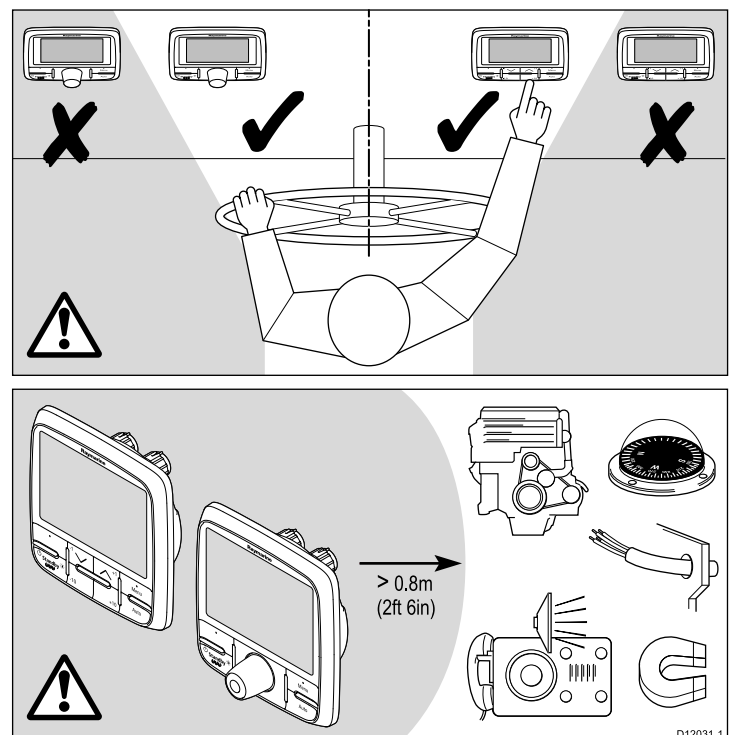

Site requirements for the p70 / p70r Pilot controller are as follows:

- There should be no obstacle between the user and the pilot controller.
- The pilot controller should be situated at least 0.8 m from an engine, compass, high current power cables, or any magnetic device.

Compass safe distance

To prevent potential interference with the vessel's magnetic compasses, ensure an adequate distance is maintained from the product.

When choosing a suitable location for the product you should aim to maintain the maximum possible distance from any compasses. Typically this distance should be at least 1 m (3 ft) in all directions. However for some smaller vessels it may not be possible to locate the product this far away from a compass. In this situation, when choosing the installation location for your product, ensure that the compass is not affected by the product when it is in a powered state.

Viewing angle considerations

As display contrast, color and night mode performance are all affected by the viewing angle, Raymarine recommends you temporarily power up the display when planning the installation, to enable you to best judge which location gives the optimum viewing angle.

3.11 Unit dimensions

p70 and p70r dimensions

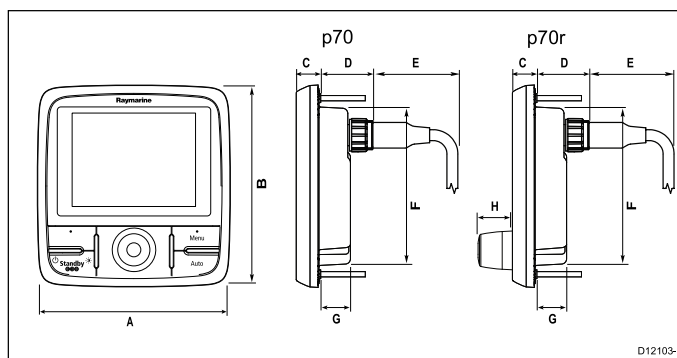

Item	Description
A.	110 mm (4.33")
B.	115 mm (4.52")
C.	14 mm (0.55")
D.	30 mm (1.18")
E.	35 mm (1.38")
F.	90 mm (3.54")
G.	17 mm (0.67")
H.	20.6 mm (0.81")

3.12 Before using your pilot controller

Before using the pilot controller under way it is important that it is properly commissioned and set up as described in the installation instruction.

First time set up

The first ever time the pilot controller is powered on, you will be shown on-screen instructions for the initial set up. If your pilot controller has been installed by a professional installer, first time set up and commissioning may already have been carried out, if unsure check with the dealer.

The first time set up screens takes you through the following:

- Language selection
- Vessel type selection

If a pilot controller already exists on your system then this procedure may be skipped and the p70 / p70r will adopt the same settings as the already installed pilot controller.

Note: If calibration has not been undertaken then the display will alarm 'Calibration required' and then show 'Starting' on the display

Commissioning

Before using your autopilot system for the first time you must ensure that the system has been correctly commissioned in accordance with the supplied installation instruction.

Commissioning procedures which must be carried out are:

- Dockside calibration (Dealer settings on SeaTalk)
- Seatrial calibration

Chapter 4: Cables and connections

Chapter contents

- [4.1 General cabling guidance on page 24](#)
- [4.2 Connections overview on page 24](#)
- [4.3 Power connection on page 25](#)
- [4.4 SeaTalk^{ng} connection on page 26](#)
- [4.5 SeaTalk connection on page 27](#)

4.1 General cabling guidance

Cable types and length

It is important to use cables of the appropriate type and length

- Unless otherwise stated use only standard cables of the correct type, supplied by Raymarine.
- Ensure that any non-Raymarine cables are of the correct quality and gauge. For example, longer power cable runs may require larger wire gauges to minimize voltage drop along the run.

Routing cables

Cables must be routed correctly, to maximize performance and prolong cable life.

- Do NOT bend cables excessively. Wherever possible, ensure a minimum bend diameter of 200 mm (8 in) / minimum bend radius of 100 mm (4 in).

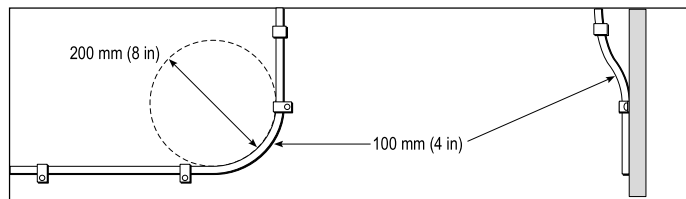

- Protect all cables from physical damage and exposure to heat. Use trunking or conduit where possible. Do NOT run cables through bilges or doorways, or close to moving or hot objects.
- Secure cables in place using tie-wraps or lacing twine. Coil any extra cable and tie it out of the way.
- Where a cable passes through an exposed bulkhead or deckhead, use a suitable watertight feed-through.
- Do NOT run cables near to engines or fluorescent lights.

Always route data cables as far away as possible from:

- other equipment and cables,
- high current carrying ac and dc power lines,
- antennae.

Caution: Pulling cables

Do NOT use cords or ropes, attached to cable connectors, to pull cables through restricted apertures (e.g. as in bulkheads), as this could cause damage to cables.

Strain relief

Ensure adequate strain relief is provided. Protect connectors from strain and ensure they will not pull out under extreme sea conditions.

Circuit isolation

Appropriate circuit isolation is required for installations using both AC and DC current:

- Always use isolating transformers or a separate power-inverter to run PC's, processors, displays and other sensitive electronic instruments or devices.
- Always use an isolating transformer with Weather FAX audio cables.
- Always use an isolated power supply when using a 3rd party audio amplifier.
- Always use an RS232/NMEA converter with optical isolation on the signal lines.
- Always make sure that PC's or other sensitive electronic devices have a dedicated power circuit.

Cable shielding

Ensure that all data cables are properly shielded that the cable shielding is intact (e.g. hasn't been scraped off by being squeezed through a tight area).

4.2 Connections overview

Cable connectors are on the rear of the product.

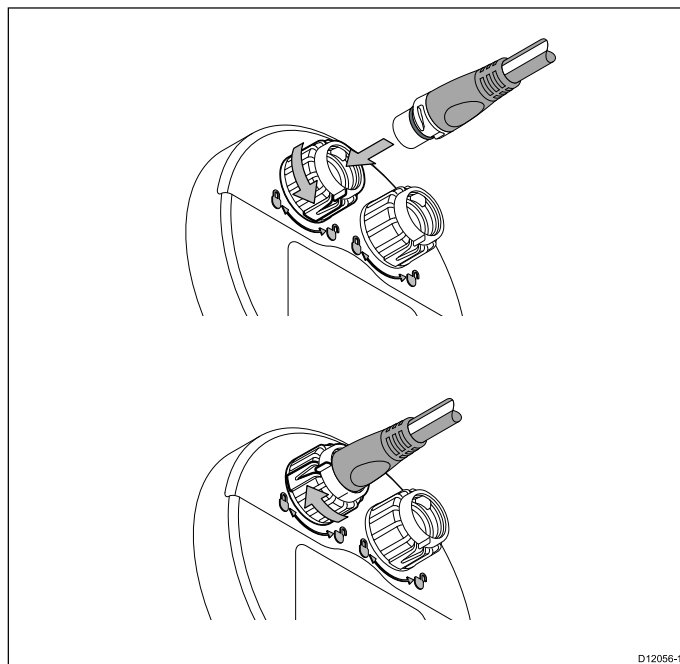

The unit has 2 x SeaTalk^{ng} connectors.

Connecting SeaTalk^{ng} cables

1. Rotate the locking collar on the back of the unit to the UNLOCKED position.
2. Ensure the spur cable end connector is correctly oriented.
3. Fully insert the cable connector.
4. Rotate locking collar clockwise (2 clicks) until it snaps into the LOCKED position.

4.3 Power connection

Power is supplied to the product over the SeaTalk^{ng} network.

A SeaTalk^{ng} system requires one 12 V dc supply, connected to the SeaTalk^{ng} backbone. This can be provided:

- By a battery via the distribution panel, or
- From a Raymarine course computer, via a SeaTalk or a SeaTalk^{ng} system.

SeaTalk^{ng} power connection

Example

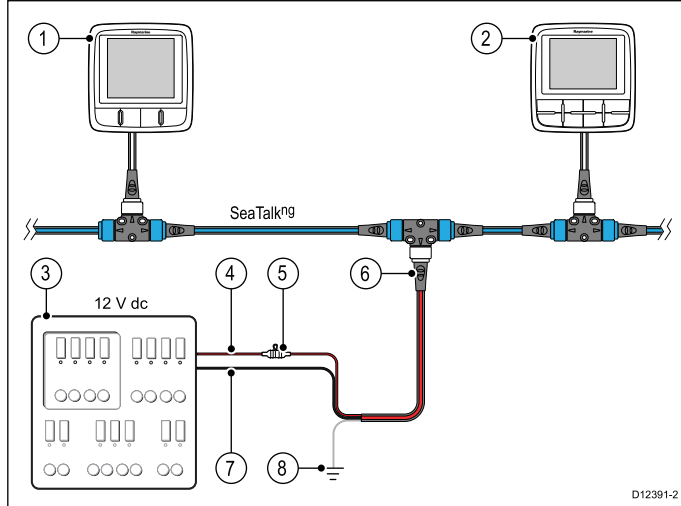

1	SeaTalk ^{ng} instrument
2	SeaTalk ^{ng} Pilot controller
3	12 V dc vessel power supply.
4	12 V dc positive (+)
5	In-line 5 A fuse
6	SeaTalk ^{ng} power cable
7	12 V dc negative (-)
8	Vessel's RF ground

Breakers, fuses and circuit protection

The information below is provided as guidance to help protect your product. The example illustrations provided are for common vessel power arrangements, if you are unsure how to provide the correct level of protection then please consult a Raymarine authorized dealer for support.

Distribution panel connection

It is recommended that your product is wired through your vessel's distribution panel via a thermal breaker or fuse.

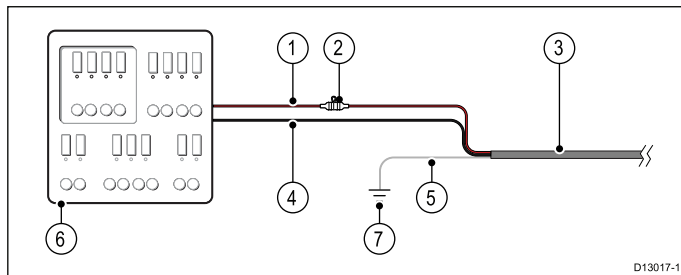

1. Vessel power supply positive (+)
2. In-line fuse (your product may contain a fuse already built in to the power cable.)
3. Product power cable
4. Vessel power supply negative (-)

5. * Drain wire
6. Vessel distribution panel
7. * Vessel RF ground point connection

Note: * Only applicable to products that include a drain wire on the product's power cable.

Thermal breaker rating
5 A (if only connecting one device)

Battery connection with RF ground

If your vessel does not have a distribution panel then your product may be wired directly to the battery with the drain wire connected to the vessel's RF ground point.

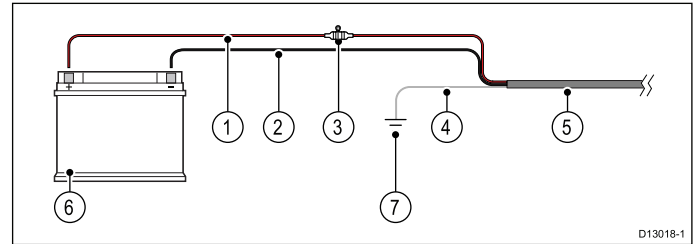

1. Vessel power supply positive (+)
2. Vessel power supply negative (-)
3. In-line fuse (If your products power cable does not have a built in fuse then an in-line fuse should be fitted.)
4. * Drain wire
5. Product power cable
6. Vessel battery
7. * Vessel RF ground point connection

Note: * Only applicable to products that include a drain wire on the product's power cable.

Battery connection with no RF ground

If your vessel does not have a distribution panel or an RF ground point then your product may be wired directly to the battery with the drain wire also connected to the battery's negative terminal.

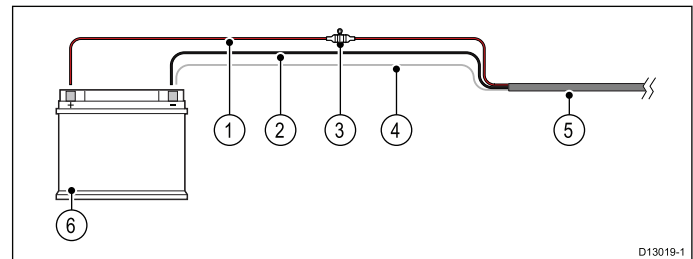

1. Vessel power supply positive (+)
2. Vessel power supply negative (-)
3. In-line fuse (If your products power cable does not have a built in fuse then an in-line fuse should be fitted.)
4. * Drain wire connected to vessel negative power supply.
5. Product power cable
6. Vessel battery

Note: * Only applicable to products that include a drain wire on the product's power cable.

Sharing a breaker

Where more than 1 piece of equipment shares a breaker you must provide protection for the individual circuits. E.g. by connecting an in-line fuse for each power circuit.

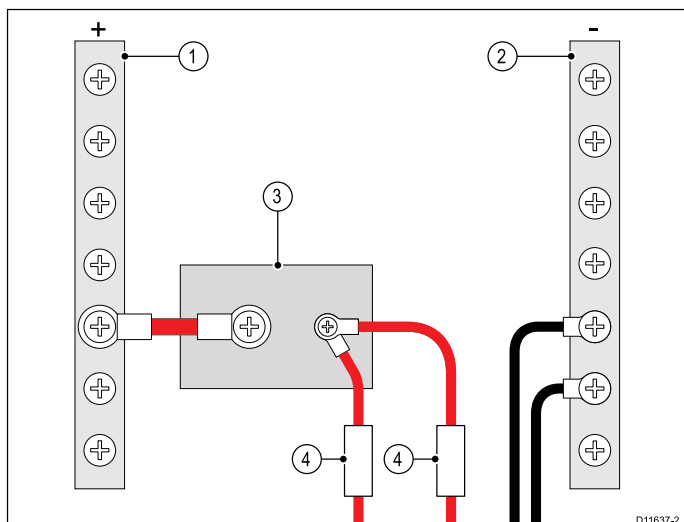

D11637-2

1	Positive (+) bar
2	Negative (-) bar
3	Circuit breaker
4	Fuse

Where possible, connect individual items of equipment to individual circuit breakers. Where this is not possible, use individual in-line fuses to provide the necessary protection.



Warning: Product grounding

Before applying power to this product, ensure it has been correctly grounded, in accordance with the instructions in this guide.

4.4 SeaTalk^{ng} connection

The unit connects as part of a SeaTalk^{ng} network.

Example: SeaTalk^{ng} Evolution system with iTC-5

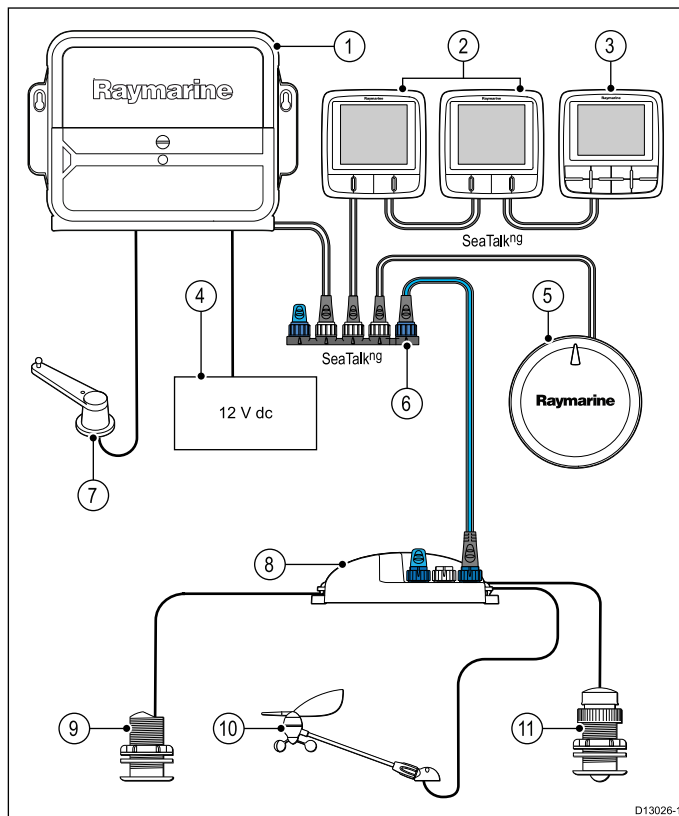

D13026-1

1	ACU unit
2	2 x Instruments
3	p70 / p70R Pilot controller
4	Vessel's 12 V dc power supply
5	EV unit
6	SeaTalk ^{ng} 5-way connector
7	Rudder reference transducer
8	iTC-5 converter
9	Depth transducer
10	Wind transducer
11	Speed transducer

Note: In the above example if an ACU-100 was used, the SeaTalk^{ng} network would require a dedicated 12 V dc power

supply because the ACU-100 does not supply power to the SeaTalk^{ng} network.

4.5 SeaTalk connection

Connections to a SeaTalk network are made using a SeaTalk to SeaTalk^{ng} adaptor cable (not supplied).

Example: SeaTalk^{ng} SPX system with transducer pods

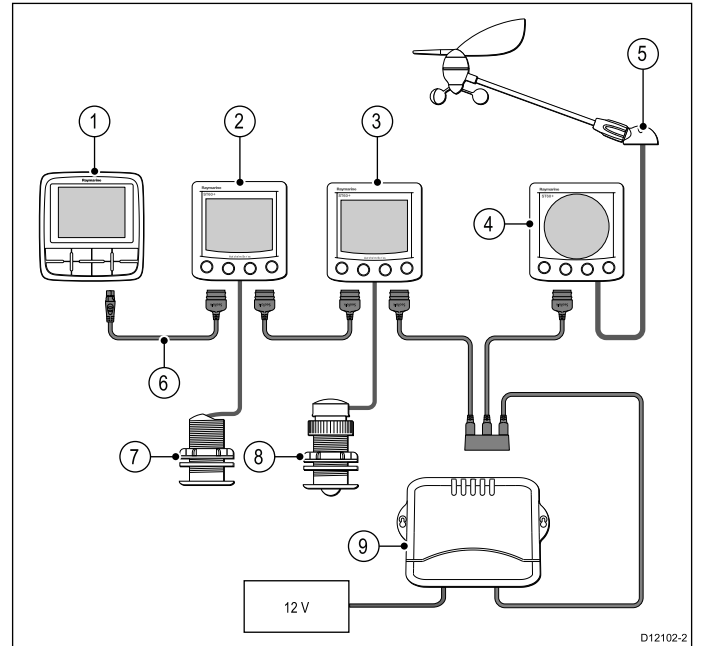
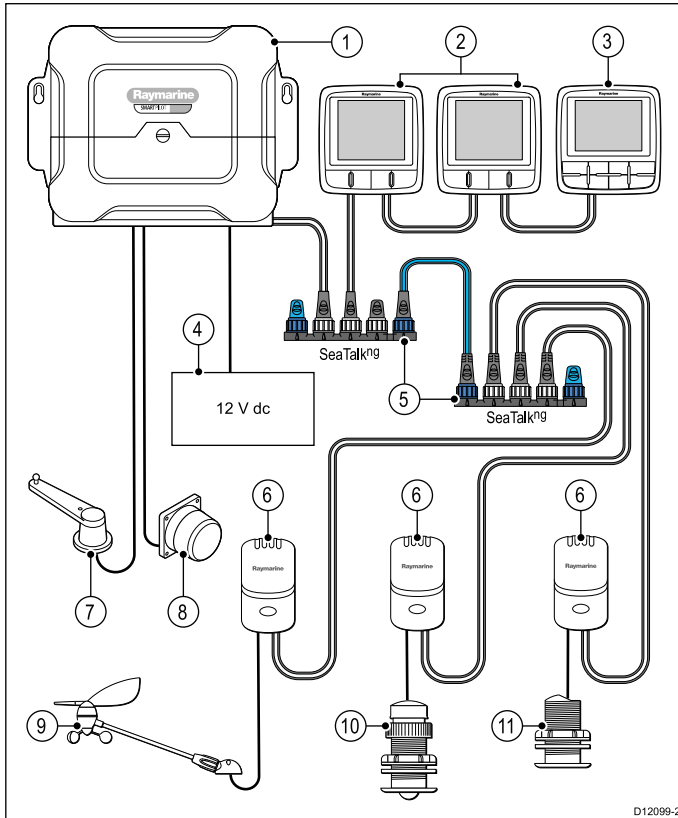

Item	Description
1	SPX (supplying 12V to SeaTalk ^{ng} network.)
2	2 x Instruments
3	p70 / p70R Pilot controller
4	Vessel's 12 V dc power supply
5	SeaTalk ^{ng} 5-way connectors with terminators
6	Transducer pods
7	Rudder reference transducer
8	Fluxgate compass
9	Wind transducer
10	Speed transducer
11	Depth transducer

Item	Description
1.	p70 Pilot controller
2.	ST60+ Depth instrument
3.	ST60+ Speed instrument
4.	ST60+ Wind instrument
5.	Wind transducer
6.	SeaTalk ^{ng} to SeaTalk Adaptor cable
7.	Depth transducer
8.	Speed transducer
9.	Course computer (supplying 12V to SeaTalk network.)

For SeaTalk cables and extensions, use Raymarine SeaTalk cable accessories.

Chapter 5: Mounting

Chapter contents

- [5.1 Mounting on page 30](#)

5.1 Mounting

The product is designed to be flush mounted.

Before mounting the unit, ensure that you have:

- Selected a suitable location.
- Identified the cable connections and route that the cable will take.
- Detached the front bezel.

p70 Mounting

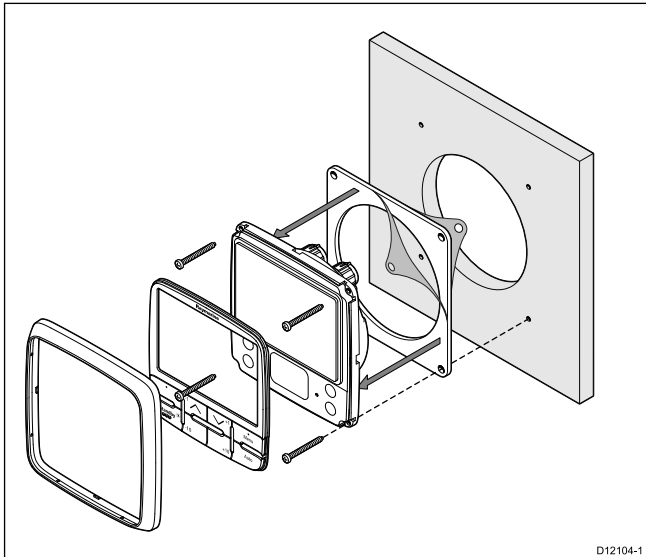

p70r Mounting

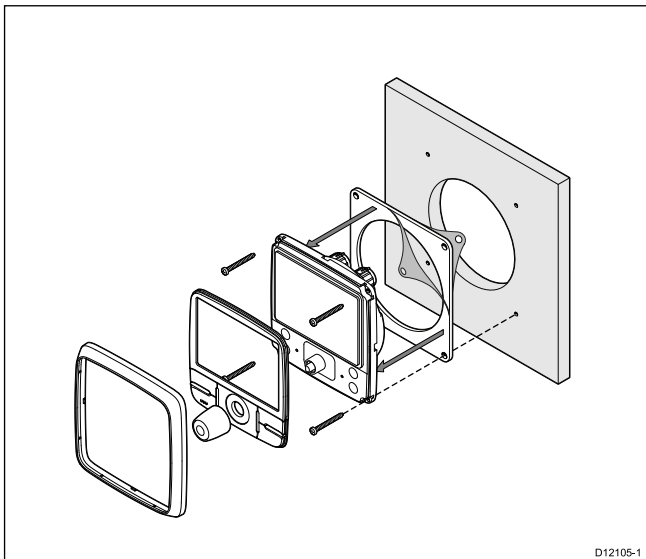

1. Check the selected location for the unit. A clear, flat area with suitable clearance behind the panel, is required.
2. Fix the appropriate cutting template supplied with the product, to the selected location, using masking or self-adhesive tape.
3. Using a suitable hole saw, make a pilot holes in each corner of the cut-out area.
4. Using a suitable saw, cut along the inside edge of the cut-out line.
5. Ensure that the unit fits into the removed area and then file around the cut edge until smooth.
6. Drill four holes as indicated on the template to accept the securing screws.
7. Peel the backing off of the gasket, and place the adhesive side of the gasket onto the display unit and press firmly onto the flange.
8. Connect cables to the unit.
9. Slide the unit into place and secure using screws provided.

Note: Drill, tap size, and tightening torque is dependent on the thickness and type of material the unit is to be mounted on.

Front bezel

Removing the front bezel

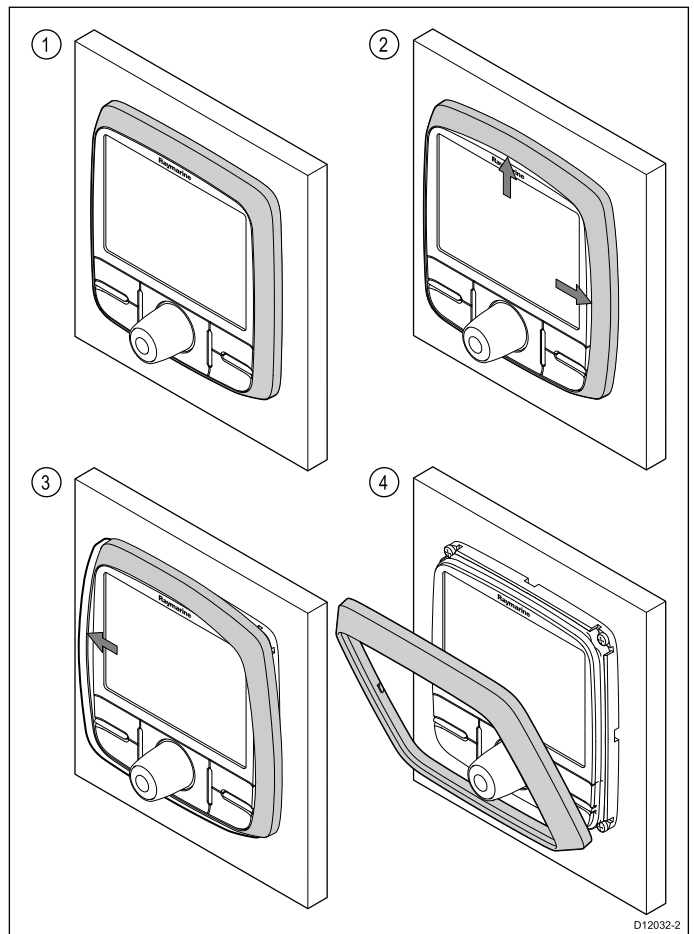

Important: Use care when removing the bezel. Do not use any tools to lever the bezel, doing so may cause damage.

1. Using your fingers pull the bezel away from the unit at the top and side, as shown in 2.
The bezel will start to come away from the unit at the top and side.
2. Now pull the bezel away from the unit on the opposite side, as shown in 3.
The bezel will now come free from the unit, as shown in 4.

Chapter 6: Getting started

Chapter contents

- [6.1 Pilot functions on page 32](#)
- [6.2 Pilot controls on page 32](#)
- [6.3 Instrument power on page 33](#)
- [6.4 Display settings on page 34](#)
- [6.5 Multiple data sources \(MDS\) on page 35](#)

6.1 Pilot functions

The SmartPilot has various modes:

Standby	Manual steering, activated by STANDBY button.
Auto	Autopilot engaged steering to a heading, activated by AUTO button.
Wind vane	Autopilot engaged steering to maintain a selected apparent or true wind angle, activated from the Mode menu, or by pressing AUTO and STANDBY together.
Track	Autopilot engaged steering to a waypoint, activated from the Mode menu.
Pattern	Autopilot engaged in fishing pattern mode, activated from the Mode menu.
Power steer (p70r rotary or joystick only)	Autopilot engaged in power steering mode, activated from the Mode menu.
Jog steer	Autopilot disengaged in jog steer mode (tiller drives and SeaTalk only), activated whilst in Standby mode.

6.2 Pilot controls

Control layout and functions.

p70 – 8 button pilot controller

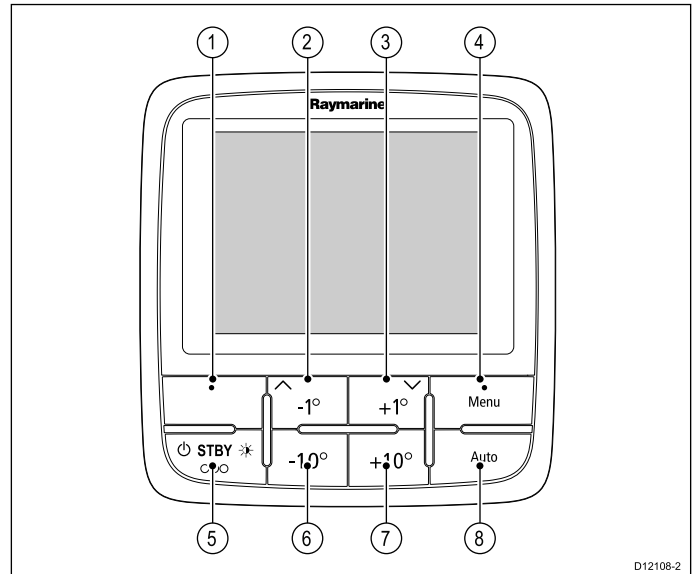

Item	Description
1.	LEFT SOFT BUTTON Cancel, Back, mode selection.
2.	UP BUTTON / -1 Up navigation, Adjust Up, Decrease angle.
3.	DOWN BUTTON / +1 Down navigation, Adjust Down, Increase angle.
4.	RIGHT SOFT BUTTON Menu, Select, OK, Save.
5.	STANDBY BUTTON Disengage pilot, Manual control, Power, Brightness.
6.	-10 BUTTON Decrease angle.
7.	+10 BUTTON Increase angle.
8.	AUTO BUTTON Engage Auto pilot.

p70r — rotary pilot controller

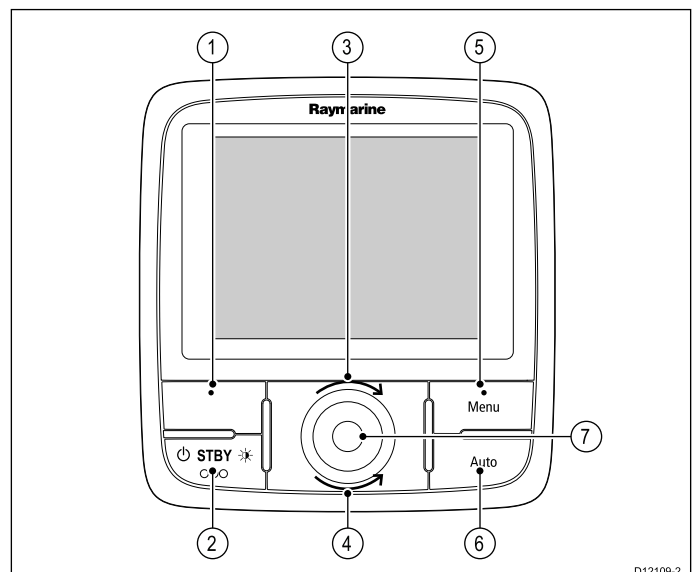

Item	Description
1.	LEFT SOFT BUTTON Cancel, Back, mode selection.
2.	STANDBY BUTTON Disengage pilot, Manual control, Power, Brightness.
3.	ROTARY CLOCKWISE Down navigation in list, Adjust Up, Increase angle (locked heading), adjust numerical values, power steer.
4.	ROTARY ANTI-CLOCKWISE Up navigation in list, Adjust Down, Decrease angle (locked heading), adjust numerical values, power steer.
5.	RIGHT SOFT BUTTON Menu, Select, OK, Save.
6.	AUTO BUTTON Engage Auto pilot.
7.	ROTARY END PUSH BUTTON Menu, Select, OK, Save.

The pilot controller supports the following combination button presses:

Combination button press

Buttons	Action
STANDBY and AUTO.	Puts pilot in to Wind Vane mode.
-1 and -10 or +1 and +10.	AutoTack (in wind vane mode), AutoTurn

6.3 Instrument power

Powering the pilot controller on

1. Press and hold the **STANDBY** button for 1 second, until the Raymarine logo appears.
The pilot controller will load to the mode page.

Powering the pilot controller off

1. From any data page press and hold the **STANDBY** button.
After 1 second a power down pop up will appear.
2. Continue to hold the **STANDBY** button for a further 3 seconds to complete the power off.

Note: The pilot controller cannot be turned off whilst in **AUTO** mode.

6.4 Display settings

Display and shared brightness

You can change the brightness of the individual display, or networked displays.

You can only use and set shared brightness on displays which support sharing and are assigned to network groups .

You will not be able to set shared brightness levels on displays which do not support sharing.

Adjusting the displays brightness

To adjust the brightness of the individual display:

1. Whilst in a favorite page momentarily press the **LEFT SOFT** button.
This will open the brightness setting screen.
2. Use the **UP** and **DOWN** buttons to change the brightness percentage to the required level.
3. Press the **RIGHT SOFT** button to confirm new brightness and go back to the favorites page you were on.

Assigning A Network Group

When assigned to a network group you can change brightness level and color scheme on displays which support sharing.

To enable shared brightness and color schemes the display must be assigned to a network group as follows:

1. Navigate to **Menu > Set Up > System Set Up > Network Group**.
A list of network groups will be displayed:
 - None (default)
 - Helm 1
 - Helm 2
 - Cockpit
 - Flybridge
 - Mast
 - Group 1 — Group 5
2. Use the **UP** and **DOWN** buttons to highlight the required group.
3. Press the **SELECT** button to assign the display you are using to that network group.
4. Navigate to **Menu > Set Up > System Set Up > Brightness/Colour Group**.
You will be presented with the following options:
 - This Display
 - This Group
5. Highlight and select the required setting.
6. Carry out steps 1 to 5 on all displays you wish to share.

Adjusting the shared brightness

Shared brightness is only accessible if the display has been assigned to a network group.

1. Whilst on a favorites page press the **LEFT SOFT** button to display the brightness setting.
2. Press the **LEFT SOFT** button again to access the shared brightness settings.
3. Use the **UP** and **DOWN** buttons to change the shared brightness level.



Display and system brightness can also be accessed via **Menu > Display settings > Brightness**.

Display and shared color

The p70 / p70r can set a color scheme for the individual display or for the system (if color is available on the network displays).

Color settings can be accessed via **Menu > Display settings > Colors**.

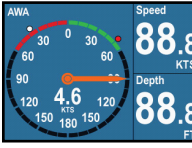
Color schemes available are:

Example	Color Scheme
	Day 1
	Day 2
	Inverse
	Red/Black

Changing the color scheme

1. From the color menu highlight a color scheme.
Once highlighted the display will preview the selected color scheme.
2. Press **SELECT** to confirm the color scheme and return to the color settings menu.

If the unit is part of a network group, the color scheme selected will change on all displays which are part of that group. If color is not available on the networked displays they will remain unchanged.

Display response

Setting the display response

Setting the response to a low value will provide a more stable reading of current conditions. Setting response to a high value will make readings more responsive.

1. From **Menu > Display settings** select **Display Response**.
2. Use the **UP** and **DOWN** buttons to select the data type:
 - Speed
 - Depth
 - Wind speed
 - Wind angle
 - Heading
3. Press **SELECT** to set the response value:
1 — 15
4. Press **SAVE** to save the value and return to the display response options screen.

6.5 Multiple data sources (MDS)

Multiple data sources (MDS) overview

Installations that include multiple instances of data sources can cause data conflicts. An example is an installation featuring more than one source of GPS data.

MDS enables you to manage conflicts involving the following types of data:

- GPS Position.
- Heading.
- Depth.
- Speed.
- Wind.

Typically this exercise is completed as part of the initial installation, or when new equipment is added.

If this exercise is NOT completed the system will automatically attempt to resolve data conflicts. However, this may result in the system choosing a source of data that you do not want to use.

If MDS is available the system can list the available data sources and allow you to select your preferred data source. For MDS to be available all products in the system that use the data sources listed above must be MDS-compliant. The system can list any products that are NOT compliant. It may be necessary to upgrade the software for these non-compliant products to make them compliant. Visit the Raymarine website (www.raymarine.com) to obtain the latest software for your products. If MDS-compliant software is not available and you do NOT want the system to automatically attempt to resolve data conflicts, any non-compliant product(s) can be removed or replaced to ensure the entire system is MDS-compliant.

Viewing vessel data sources

You can view available multiple data sources on a system by following the steps below:

1. Go to the MDS menu: **Main menu > Setup > System setup > Multiple data source.**
2. Highlight the required data type:
 - GPS position
 - Heading
 - Depth
 - Speed
 - Wind
3. Press **SELECT**.
You will be shown a list of all available data sources for the chosen data type.
4. Highlight a data type and press **SELECT**
You will now see detailed information about the data source which will include:
 - Device
 - Serial number
 - Port ID
 - Status

Selecting a preferred data source

To select a preferred data source for your system:

1. Go to the MDS menu: **Main menu > Setup > System setup > Multiple data source.**
2. Press **OPTIONS**.
3. Highlight **Selection** and press **SELECT**.
4. Highlight **Manual** and press **SELECT**
You will be taken back to the source options screen.
5. Highlight **Use this source** and press **SELECT**

6. To let the system automatically select a data source at the source selection screen highlight and press **AUTO**.

Where displays on your system are not capable in participating in MDS you will be shown a list of the devices that do not support this feature.

Chapter 7: Commissioning - Evolution autopilot system

Chapter contents

- [7.1 Evolution autopilot installation on page 38](#)
- [7.2 Autopilot commissioning — main differences between Evolution and SPX systems on page 38](#)
- [7.3 Autopilot response levels on page 39](#)
- [7.4 Initial setup and commissioning on page 39](#)
- [7.5 Powering the pilot controller on on page 40](#)
- [7.6 Using the set-up wizard on page 40](#)
- [7.7 Using the Dockside wizard on page 41](#)
- [7.8 Adjusting the hard-over time on page 42](#)
- [7.9 Compass linearization on page 42](#)
- [7.10 Compass lock on page 43](#)

7.1 Evolution autopilot installation

For information on installing and connecting an Evolution autopilot system, refer to the installation instructions that accompany the EV-1 and EV-2 units, as appropriate.

7.2 Autopilot commissioning — main differences between Evolution and SPX systems

The Evolution system provides a number of features to improve upon the commissioning process required by existing SPX and some other autopilot systems.

- **Built-in heading and attitude sensor** — no additional fluxgate compass required.
- **Automatic set-up** — the rudder gain, counter rudder, manual compass calibration and autolearn settings required for existing SPX systems are no longer required. This results in a greatly simplified dockside calibration process for Evolution autopilot systems.

7.3 Autopilot response levels

The Evolution autopilot system features a number of different response levels to help you quickly configure the system for optimum performance for the current conditions.

The available response levels are:

- **Leisure** — suitable for long passages where tight heading control is not critical.
- **Cruising** — good course-keeping without overworking the pilot.
- **Performance** — emphasis on tight heading control.

You can change the response level at any time by selecting **MENU > Response Level**. Then select **Save** to keep the changes.

7.4 Initial setup and commissioning

Commissioning pre-requisites

Before commissioning your system for the first time, check that the following processes have been carried out correctly:

- Autopilot system installation completed in accordance with the Installation Guide.
- SeaTalk^{ng} network installed in accordance with the SeaTalk^{ng} Reference Manual.
- Where fitted, GPS installation and connections has been carried out in accordance with the GPS installation guide.

Check also that the commissioning engineer is familiar with the installation and components of the autopilot system including:

- Vessel type.
- Vessel steering system information.
- What the autopilot will be used for.
- System layout: components and connections (you should have a schematic of the vessel's autopilot system).

Initial set-up

Initial set-up involves the following steps:

Important: Before proceeding with the initial set-up or commissioning of a p70 / p70R, ensure that your p70 / p70R is running the latest software. p70 / p70R operation with Evolution systems requires p70 / p70R software version 2 or later. Refer to <http://www.raymarine.co.uk/view/?id=797> to download the latest software and view instructions on how to upgrade the software on your p70 / p70R, using a multifunction display.

1. Power-up your p70 / p70R.
2. Specify your preferred language and appropriate vessel type, using the **Set-up wizard**.
3. Complete the dockside calibration process, using the **Dockside wizard**:

For vessels without a rudder reference transducer:	For vessels with a rudder reference transducer:
Drive Type selection	Drive Type selection
	Align Rudder (rudder alignment)
Rudder Limit setting	Rudder Limit setting
Hard Over Time (if you do not already know your hard over time, you should skip this step in the Dockside Wizard and enter the value manually afterwards.	
Rudder Drive check	Rudder Drive check

4. Once the dockside wizard is complete, specify the hard-over time (only applies to systems that do NOT include a rudder reference transducer).
5. Familiarize yourself with the important information in this document related to **compass linearization**. Follow the guidelines provided to ensure that the process is completed successfully.
6. Once you've successfully completed all the steps listed above, you should also familiarize yourself with the information related to **compass lock**.

7.5 Powering the pilot controller on

Turning on the pilot controller

1. Press and hold the **STANDBY** button for one second until the Raymarine logo appears.

If the unit is being switched on for the first time or after a factory reset the set up wizard will be launched.

Note: The Raymarine logo is not displayed if the unit is in 'sleep mode', the unit may appear off but still has power.

2. To turn the pilot controller off press and hold the **STANDBY** button. After 1 second a pop up will appear.
3. Continue to hold the **STANDBY** button for as further 3 seconds to complete the power off.

Note: You cannot power down the pilot controller whilst in **AUTO** mode.

7.6 Using the set-up wizard

The set-up wizard guides you through the steps for setting important preferences, such as preferred language and correct vessel type.

The set up wizard contains 3 steps: language selection, vessel type and welcome screen. When powering the p70 / p70r for the first time in an unconfigured system, this set-up wizard is displayed automatically, and the first 3 steps listed below will not be required.

With the pilot in **Standby** mode:

1. Select **Menu**.
2. Select **Set-up**.
3. Select **Set-up wizard**.
4. Select the required language.
5. Select the required vessel type.

The welcome screen will now be displayed and your choices have been saved.

6. Select **OK** to complete the set-up wizard.

Vessel hull type selection

The vessel hull type options are designed to provide optimum steering performance for typical vessels.

It is important to complete the vessel hull type selection as part of the initial set-up, as it forms a key part of the autopilot calibration process. You can also access the options at any time with the pilot in Standby by selecting **MENU > Set-up > Autopilot Calibration > Vessel Settings > Vessel Hull Type**.

As a general guide, select the option that most closely matches your vessel type and steering characteristics. The options are:

- **Sail**.
- **Sail (Slow turn)**.
- **Sail Catamaran**.
- **Power**.
- **Power (slow turn)**.
- **Power (fast turn)**.

It is important to be aware that steering forces (and therefore rate-of-turn) vary significantly depending on the combination of vessel type, steering system, and drive type. Therefore, the available vessel hull type options are provided for guidance only. You may wish to experiment with the different vessel hull type options, as it might be possible to improve the steering performance of your vessel by selecting a different vessel type.

When choosing a suitable vessel type, the emphasis should be on safe and dependable steering response.

Important: If you change the vessel type **after** completing the Dockside calibration process (using the Dockside wizard), all commissioning settings will be reset to default settings, and you will need to complete the Dockside calibration process again.

7.7 Using the Dockside wizard

The dockside calibration process must be completed before the Evolution autopilot system can be used for the first time. The Dockside wizard guides you through the steps required for dockside calibration.

The Dockside wizard contains different steps depending on whether you have a rudder reference transducer fitted to your vessel:

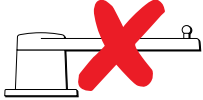
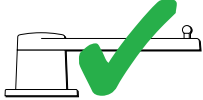
	
<p>The following Dockside wizard procedures only apply to vessels without a rudder reference transducer:</p> <ul style="list-style-type: none"> • Drive Type selection. • Rudder Limit setting. • Hard-over time setting (Raymarine recommends that this information is specified once the dockside wizard and Rudder Drive check is complete, using the Hard Over Time menu option). • Rudder Drive check. 	<p>The following Dockside wizard procedures only apply to vessels with a rudder reference transducer:</p> <ul style="list-style-type: none"> • Drive Type selection. • Align Rudder (rudder alignment). • Rudder Limit setting. • Rudder Drive check.

To access the wizard, ensure the pilot is in **Standby** mode and then:

1. Select **Menu**.
2. Select **Set-up**.
3. Select **Autopilot Calibration**.
4. Select **Commissioning**.
5. Select **Dockside Wizard**.

Selecting a drive type

Drive Type selection is available when the pilot is in standby, from either the Dockside wizard, or from the Vessel setting menu: **MENU > Set-up > Autopilot Calibration > Vessel Settings**.

With the **Drive Type** menu displayed:

1. Select your drive type.

Note: If your drive type is not listed, contact your Raymarine dealer for advice.

Checking the rudder alignment (Align Rudder)

This procedure establishes port and starboard rudder limits for systems using a rudder reference transducer.

The rudder check forms part of the dockside calibration process.

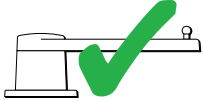
	<p>The following procedure only applies to vessels with a rudder reference transducer.</p>
---	--

1. Center the rudder and select **OK**.
2. When prompted, turn the rudder hard to port and select **OK**.
3. When prompted, turn the rudder hard to starboard and select **OK**.
4. When prompted, turn the rudder back to the center and select **OK**.

Note: You can cancel Dockside calibration at any time by selecting **STANDBY**.

Rudder Limit setting

As part of the Dockside calibration process, the system will set-up the rudder limits.

- **For vessels with a rudder reference transducer** — This procedure establishes the rudder limit. The rudder limit will be displayed with a message confirming that the rudder limit has been updated. This value can be changed if required.
- **For vessels without a rudder reference transducer** — a default of 30 degrees is displayed, and can be changed as required.

Hard over time

The hard over time setting can be specified as part of the Dockside wizard.

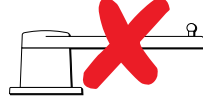
	<p>The following information only applies to vessels without a rudder reference transducer.</p>
--	---

- **If you already know the hard-over time** for your vessel's steering system: enter this time during the Dockside wizard procedure.
- **If you do NOT know the hard-over time** for your vessel's steering system: skip this step during the Dockside wizard procedure by selecting **SAVE**, then proceed to [Checking the rudder drive](#) section in this document to complete the Dockside wizard procedure. Once the wizard is complete, proceed to [7.8 Adjusting the hard-over time](#) in this document for information on how to calculate and adjust the hard-over time.

Checking the rudder drive

As part of the dockside calibration process, the system will check the drive connection. Once it has completed the check successfully, a message will appear asking if it is safe for the system to take the helm.

During this procedure the autopilot will move the rudder. Ensure it is safe to proceed before pressing OK.

When in dockside calibration mode, with the Motor Check page displayed:

1. Centre and let go of the rudder.
2. Disengage any rudder drive clutch.
3. Select **CONTINUE**.
4. Check it is safe to proceed before selecting **OK**.
For vessels **with** a rudder reference transducer, the autopilot will now automatically move the rudder to port and then starboard.
5. For vessels **without** a rudder reference transducer, you will be asked to confirm that the rudder has turned to port by selecting **YES** or **NO**.
6. Select **OK** if it is safe to engage the rudder in the opposite direction.
7. You will be asked to confirm the rudder turned to starboard by selecting **YES** or **NO**.
8. Dockside calibration is now complete, select **CONTINUE**.

Note: If you confirmed a "NO" response for the rudder movement to both port and starboard, the wizard will exit. It is possible that the steering system did not move the rudder in any direction, and it will be necessary to check the steering system before completing the Dockside wizard procedure again.

You can cancel Dockside calibration at any time by pressing **STANDBY**.

7.8 Adjusting the hard-over time

On vessels without a rudder reference transducer, it is important to set a Hard Over Time.

Before attempting to follow this procedure ensure you have read and understood the Rudder Check warning provided in this document.

To estimate your hard over time follow the steps below:

1. On SmartPilot and SPX systems, adjust your Rudder Gain setting to the maximum value, making a note of the original value. The Rudder Gain setting can be accessed from the Drive Setting menu: **Menu > Set-up > Autopilot Calibration > Drive Settings > Rudder Gain**.
2. With the autopilot in **Standby**, manually turn the rudder / engine full to port. (For vessels with power steering the engine should be running when turning the rudder.)
3. Engage **Auto** mode.
4. Press the **+10** and **+1** buttons at the same time (p70) or use the **Rotary** (p70R) to alter your locked heading by 90 degrees, use a stop watch to time the movement of the rudder / engine.
5. Estimate how long it would take to move the rudder from full port to full starboard. This estimate is your **Hard Over Time**.
6. Enter this estimate as your Hard Over Time. The Hard Over time setting can be accessed from the Drive Settings menu: **Menu > Set-up > Autopilot Calibration > Drive Settings > Hard Over Time**.
7. On SmartPilot and SPX systems change your Rudder Gain back to its original value.
8. After setting your Hard Over Time, observe your autopilot's behavior and if required, make small adjustments to the Hard Over Time value until a satisfactory result is achieved.



Warning: Rudder check

If no rudder reference has been fitted you **MUST** ensure that adequate provision is made to prevent the steering mechanism from impacting the end stops.

7.9 Compass linearization

With Evolution autopilot systems, when the EV unit is first installed and powered-up, its internal compass needs to compensate for local magnetic variations and the earth's magnetic field. This is achieved using an automatic process known as linearization, which forms an important part of the autopilot installation, commissioning and set-up process.

Linearization

In Evolution systems, the linearization process is performed automatically by the EV unit as a background task when the vessel's speed is between 3 and 15 knots, no user intervention is required however at least a 270 degree turn is required. The process will occur during your first voyage with the autopilot system, and will typically take no more than 30 minutes, but this does vary according to the characteristics of the vessel, the installation environment of the EV unit, and the levels of magnetic interference at the time of conducting the process. Sources of significant magnetic interference may increase the time required to complete the linearization process. Examples of such sources include:

- Marine pontoons.
- Metal-hulled vessels.
- Undersea cables.

Note: You can speed-up the linearization process by completing a 360 degree turn (at a speed of 3 – 15 knots). You can also restart the linearization process at any time by selecting the **Restart Compass** menu item.

Use the compass deviation indicator

The use of the compass deviation indicator on the pilot control head may be useful in this process, particularly if the EV unit has been installed in a location on the vessel where the levels of magnetic interference are too high for the EV unit to compensate appropriately. If this is the case, the deviation display will indicate a value of 25 degrees or higher. In this scenario, Raymarine highly recommends that the EV unit is moved and re-installed in a location which is subject to less magnetic interference. If “-” is displayed as the Deviation value, it means that linearization has not been successfully completed yet.

Check the compass heading data

As part of the autopilot system commissioning process, Raymarine recommends that you check the compass heading value displayed on your autopilot control head or multifunction display, against a good known heading source on various headings. This will help you to determine when the EV unit has completed its linearization process.

Note: Once the linearization process has completed, it is possible that the heading value may have a slight offset of 2 to 3 degrees. This is common where installation space is limited, and the EV unit cannot be properly aligned to the vessel's longitudinal axis. In this case, it is possible to manually adjust the compass offset value using the pilot control head or multifunction display, and fine-tune the heading to an accurate value.

Note: Do NOT rely on the heading accuracy until you are satisfied that compass linearization and alignment is complete.

System monitoring and adaptation

To ensure optimum performance, after the initial linearization process is complete the EV continues to monitor and adapt the compass linearization to suit current conditions.

If the conditions for linearization are less than ideal, the automatic linearization process temporarily pauses until conditions improve again. The following conditions can cause the linearization process to temporarily pause:

- Boat speed is less than 3 knots.
- Boat speed is greater than 15 knots.
- Rate-of-turn is too slow.
- Significant external magnetic interference is present.

Accessing the compass deviation indicator

1. Select **MENU**.
2. Select **Set-up**.
3. Select **Diagnostics**.
4. Select **About Pilot**.
The details related to the pilot diagnostics are displayed.
5. Scroll down to the bottom of the list to view the entry for **Deviation**.

Note: If “-” is displayed as the Deviation value, it means that linearization has not been successfully completed yet.

Adjusting the compass offset

With the pilot in Standby:

1. Select **MENU**.
2. Select **Set-up**.
3. Select **Autopilot Calibration**.
4. Select **Vessel Settings**.
5. Select **Compass Offset**.
6. Use the +/- **10** button (p70) or **ROTARY** control (p70r) to adjust the compass offset as appropriate.

7.10 Compass lock

Once you are satisfied with the compass accuracy, you can lock the setting to prevent the autopilot system from completing a further automatic linearization in the future.

This feature is particularly useful for vessels in environments that are exposed to strong magnetic disturbances on a regular basis (such as offshore wind farms or very busy rivers, for example). In these situations it may be desirable to use the Compass lock feature to disable the continuous linearization process, as the magnetic interference may build a heading error over time.

Note: The compass lock may be released at any time, to allow the compass continuous linearization to restart. This is particularly useful if planning a long voyage. The earth's magnetic field will change significantly from one geographical location to another, and the compass can continuously compensate for the changes, ensuring you maintain accurate heading data throughout the voyage.

Chapter 8: Commissioning - SPX and SmartPilot systems

Chapter contents

- 8.1 SPX and SmartPilot autopilot installation on page 46
- 8.2 Pilot response on page 46
- 8.3 Initial setup and commissioning on page 47
- 8.4 Powering the pilot controller on on page 47
- 8.5 Using the set-up wizard on page 48
- 8.6 Dockside calibration on page 48
- 8.7 Dealer settings on page 49
- 8.8 Adjusting the hard-over time on page 50
- 8.9 Sea trial calibration on page 50
- 8.10 Checking autopilot operation on page 51

8.1 SPX and SmartPilot autopilot installation

For information on installing and connecting an SeaTalk^{ng} SPX autopilot system or a SeaTalk SmartPilot autopilot system, refer to the installation instructions that accompanied your course computer.

8.2 Pilot response

The response level controls the relationship between course keeping accuracy and the amount of helm/ drive activity. Range is from 1 to 9.

Making temporary changes to pilot response

Pilot response is set up during commissioning of the SmartPilot system however you can make temporary changes to the pilot response at any time by accessing the **Pilot response** menu from; **Main menu > Pilot Response**

1. From the Main menu highlight **Pilot response** and press **SELECT**.
2. Use the **UP** and **DOWN** buttons to change the response value to the required setting.
3. Press **SAVE** to save the response value.

Setting	Options
Levels 1 to 3	Minimize the amount of pilot activity. This conserves power, but may compromise short-term course-keeping accuracy.
Levels 4 to 6	Should give good course keeping with crisp, well controlled turns under normal operating conditions.
Levels 7 to 9	Gives the tightest course keeping and greatest rudder activity (and power consumption). This can lead to a rough passage in open waters as the SPX system may 'fight' the sea.

8.3 Initial setup and commissioning

Commissioning pre-requisites

Before commissioning your system for the first time, check that the following processes have been carried out correctly:

- Autopilot system installation completed in accordance with the Installation Guide.
- SeaTalk^{ng} network installed in accordance with the SeaTalk^{ng} Reference Manual.
- Where fitted, GPS installation and connections has been carried out in accordance with the GPS installation guide.

Check also that the commissioning engineer is familiar with the installation and components of the autopilot system including:

- Vessel type.
- Vessel steering system information.
- What the autopilot will be used for.
- System layout: components and connections (you should have a schematic of the vessel's autopilot system).

Commissioning process

- Check you have adhered to commissioning pre-requisites
- Initial power on and set-up
- Dockside calibration (Dealer Settings on SeaTalk systems)
- Set hard over time (non-rudder reference systems only)
- Sea trial calibration
- System checks

8.4 Powering the pilot controller on

Turning on the pilot controller

1. Press and hold the **STANDBY** button for one second until the Raymarine logo appears.

If the unit is being switched on for the first time or after a factory reset the set up wizard will be launched.

Note: The Raymarine logo is not displayed if the unit is in 'sleep mode', the unit may appear off but still has power.

2. To turn the pilot controller off press and hold the **STANDBY** button. After 1 second a pop up will appear.
3. Continue to hold the **STANDBY** button for as further 3 seconds to complete the power off.

Note: You cannot power down the pilot controller whilst in **AUTO** mode.

8.5 Using the set-up wizard

The set-up wizard guides you through the steps for setting important preferences, such as preferred language and correct vessel type.

The set up wizard contains 3 steps: language selection, vessel type and welcome screen. When powering the p70 / p70r for the first time in an unconfigured system, this set-up wizard is displayed automatically, and the first 3 steps listed below will not be required.

With the pilot in **Standby** mode:

1. Select **Menu**.
2. Select **Set-up**.
3. Select **Set-up wizard**.
4. Select the required language.
5. Select the required vessel type.
The welcome screen will now be displayed and your choices have been saved.
6. Select **OK** to complete the set-up wizard.

Vessel hull type selection

The vessel hull type options are designed to provide optimum steering performance for typical vessels.

It is important to complete the vessel hull type selection as part of the initial set-up wizard, as it forms a key part of the autopilot calibration process. You can also access the options at any time with the pilot in Standby by selecting **MENU > Set-up > Autopilot Calibration > Vessel Settings > Vessel Hull Type**.

As a general guide, select the option that most closely matches your vessel type and steering characteristics. The options are:

- **Race Sail.**
- **Sail Cruiser.**
- **Catamaran.**
- **Workboat.**
- **RIB.**
- **Outboard Speedboat**
- **Inboard Speedboat**
- **Power Cruiser 1 (<12 kts)**
- **Power Cruiser 2 (<30 kts)**
- **Power Cruiser 3 (>30 kts)**
- **Sport Fishing**
- **Pro Fishing**

It is important to be aware that steering forces (and therefore rate-of-turn) vary significantly depending on the combination of vessel type, steering system, and drive type. Therefore, the available vessel hull type options are provided for guidance only. You may wish to experiment with the different vessel hull type options, as it might be possible to improve the steering performance of your vessel by selecting a different vessel type.

When choosing a suitable vessel type, the emphasis should be on safe and dependable steering response.

Important: If you change the vessel type **after** completing the Dockside calibration process (using the Dockside wizard), all commissioning settings will be reset to default settings, and you will need to complete the Dockside calibration process again.

8.6 Dockside calibration

The dockside calibration process must be completed before your SPX autopilot system can be used for the first time. The Dockside wizard guides you through the steps required for dockside calibration.

The Dockside wizard contains different steps depending on whether you have a rudder reference transducer fitted to your vessel:

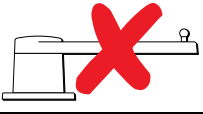
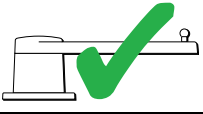
	
The following Dockside wizard procedures only apply to vessels without a rudder reference transducer: <ul style="list-style-type: none"> • Drive Type selection. • Rudder Limit setting. • Rudder Drive check. 	The following Dockside wizard procedures only apply to vessels with a rudder reference transducer: <ul style="list-style-type: none"> • Drive Type selection. • Align Rudder (rudder alignment). • Rudder Limit setting. • Rudder Drive check.

On older SeaTalk SmartPilot systems the Dockside wizard is named Dealer Settings. Please refer to [8.7 Dealer settings](#) for calibration details.

Using the Dockside wizard

To access the dockside wizard follow the steps below:

Ensure the pilot is in **Standby**.

1. Select **Menu**.
2. Select **Set-up**.
3. Select **Autopilot Calibration**.
4. Select **Commissioning**.
5. Select **Dockside Wizard**.
6. Follow the on-screen instructions.

Note: You can cancel the Dockside wizard at any time by pressing the **Standby** button.

Selecting a drive type

Drive Type selection is available when the pilot is in standby, from either the Dockside wizard, or from the Vessel setting menu: **MENU > Set-up > Autopilot Calibration > Vessel Settings**.

With the **Drive Type** menu displayed:

1. Select your drive type.

Note: If your drive type is not listed, contact your Raymarine dealer for advice.

Checking the rudder alignment (Align Rudder)

This procedure establishes port and starboard rudder limits for systems using a rudder reference transducer.

The rudder check forms part of the dockside calibration process.

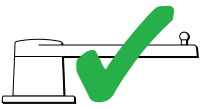
	The following procedure only applies to vessels with a rudder reference transducer.
--	---

1. Center the rudder and select **OK**.
2. When prompted, turn the rudder hard to port and select **OK**.
3. When prompted, turn the rudder hard to starboard and select **OK**.
4. When prompted, turn the rudder back to the center and select **OK**.

Note: You can cancel Dockside calibration at any time by selecting **STANDBY**.

Rudder Limit setting

As part of the Dockside calibration process, the system will set-up the rudder limits.

- **For vessels with a rudder reference transducer** — This procedure establishes the rudder limit. The rudder limit will be displayed with a message confirming that the rudder limit has been updated. This value can be changed if required.
- **For vessels without a rudder reference transducer** — a default of 30 degrees is displayed, and can be changed as required.

Checking the rudder drive

As part of the dockside calibration process, the system will check the drive connection. Once it has completed the check successfully, a message will appear asking if it is safe for the system to take the helm.

During this procedure the autopilot will move the rudder. Ensure it is safe to proceed before pressing OK.

When in dockside calibration mode, with the Motor Check page displayed:

1. Centre and let go of the rudder.
2. Disengage any rudder drive clutch.
3. Select **CONTINUE**.
4. Check it is safe to proceed before selecting **OK**.

For vessels **with** a rudder reference transducer, the autopilot will now automatically move the rudder to port and then starboard.

5. For vessels **without** a rudder reference transducer, you will be asked to confirm that the rudder has turned to port by selecting **YES** or **NO**.
6. Select **OK** if it is safe to engage the rudder in the opposite direction.
7. You will be asked to confirm the rudder turned to starboard by selecting **YES** or **NO**.
8. Dockside calibration is now complete, select **CONTINUE**.

Note: If you confirmed a “NO” response for the rudder movement to both port and starboard, the wizard will exit. It is possible that the steering system did not move the rudder in any direction, and it will be necessary to check the steering system before completing the Dockside wizard procedure again.

You can cancel Dockside calibration at any time by pressing **STANDBY**.

8.7 Dealer settings

The dockside calibration wizard is only available on a SeaTalk^{ng} system, for SeaTalk systems the **Dealer settings** should be set before going out on the sea.

The dealer settings menu can be accessed from: **Main menu > Set up > Auto pilot calibration > Dealer settings**. Once entered the dealer settings menu will cycle through all available options.

Options and limits are dependent on the course computer installed.

8.8 Adjusting the hard-over time

On vessels without a rudder reference transducer, it is important to set a Hard Over Time.

Before attempting to follow this procedure ensure you have read and understood the Rudder Check warning provided in this document.

To estimate your hard over time follow the steps below:

1. On SmartPilot and SPX systems, adjust your Rudder Gain setting to the maximum value, making a note of the original value. The Rudder Gain setting can be accessed from the Drive Setting menu: **Menu > Set-up > Autopilot Calibration > Drive Settings > Rudder Gain**.
2. With the autopilot in **Standby**, manually turn the rudder / engine full to port. (For vessels with power steering the engine should be running when turning the rudder.)
3. Engage **Auto** mode.
4. Press the **+10** and **+1** buttons at the same time (p70) or use the **Rotary** (p70R) to alter your locked heading by 90 degrees, use a stop watch to time the movement of the rudder / engine.
5. Estimate how long it would take to move the rudder from full port to full starboard. This estimate is your **Hard Over Time**.
6. Enter this estimate as your Hard Over Time. The Hard Over time setting can be accessed from the Drive Settings menu: **Menu > Set-up > Autopilot Calibration > Drive Settings > Hard Over Time**.
7. On SmartPilot and SPX systems change your Rudder Gain back to its original value.
8. After setting your Hard Over Time, observe your autopilot's behavior and if required, make small adjustments to the Hard Over Time value until a satisfactory result is achieved.



Warning: Rudder check

If no rudder reference has been fitted you **MUST** ensure that adequate provision is made to prevent the steering mechanism from impacting the end stops.

8.9 Sea trial calibration

Before you can use the autopilot open water checks are required. The water must be calm, with light or no wind. Leave plenty of room to manoeuvre. The Sea Trial wizard guides you through the steps required for Sea trial calibration.

The Sea trial wizard includes the following steps:

- Swing compass
- Align compass to GPS
- Align compass manually
- Auto Learn.

You can access the Sea trial wizard at any time from the Commissioning menu: **Menu > Set-up > Autopilot calibration > Commissioning**.

Note: Sailing vessels should perform the sea trial under engine power.

Note: The Sea trial wizard can be cancelled at any time by pressing the **Standby** button.



Warning: Seatrial calibration

Ensure you have sufficient sea room for calibration. The seatrial calibration maneuvers require a clear, familiar area of water. Ensure you are not likely to collide with any vessel or other obstruction during calibration.



Warning: Maintain sensible speeds

The autopilot may make unexpected turns.

Compass swing

You will need to turn your vessel in slow circles while the system automatically makes adjustments to account for compass deviation. Each 360-degree circle should take no less than two minutes, and you should complete at least two circles.

1. Start moving vessel in slow even circles, then press **START**.
2. Keep speed to below 2 knots. Watch the display to ensure your turn rate is not too fast. If the message 'Slow Down' is displayed reduce your rate of turn, this can be achieved by slowing down and / or steering in a wider circle.
If a 'Slow Down' message is displayed the current circle will have to be repeated.
3. When the compass has been calibrated, a message will be displayed showing the detected deviation. If this is more than 15 degrees you will need to abort the calibration process and resite the compass further away from metal items, then repeat the calibration process. If you still find a deviation of more than 15 degrees, contact your Raymarine dealer for advice. If the deviation is within acceptable limits, press **CONTINUE**.

You can cancel Seatrial calibration at any time by pressing **STANDBY**.

Aligning compass to GPS

Note: Systems without a GPS will skip this section and go straight to Manual compass alignment.

If your system has a GPS connected to your data network (SeaTalk, SeaTalk^{ng} or NMEA), the autopilot is tuned to the GPS heading while you steer to a known magnetic heading. This step provides a rough alignment and minimizes the amount of compass fine tuning required.

1. Steer the vessel on a steady course with minimal tide, increase speed to more than 3 knots and press **START** to align the compass to GPS.
2. Follow the on-screen instructions until the process completes, press the **CONTINUE** button when it is available to begin autolearn.

You can cancel Seatrial calibration at any time by pressing **STANDBY**.

Aligning compass manually

Where no GPS is present manual alignment of the compass is required.

1. Continue to steer on a steady course and use the Use **+1** and **-1** buttons, or the **ROTARY** controller to adjust the heading displayed until it matches the vessel's compass reading.
2. When complete press **CONTINUE** to begin **Autolearn**.

Auto Learn

You must have significant clear water in front of the vessel to accommodate a series of maneuvers, which include sudden, sharp turns. There should be a clear area at least 100m wide and 500m ahead.

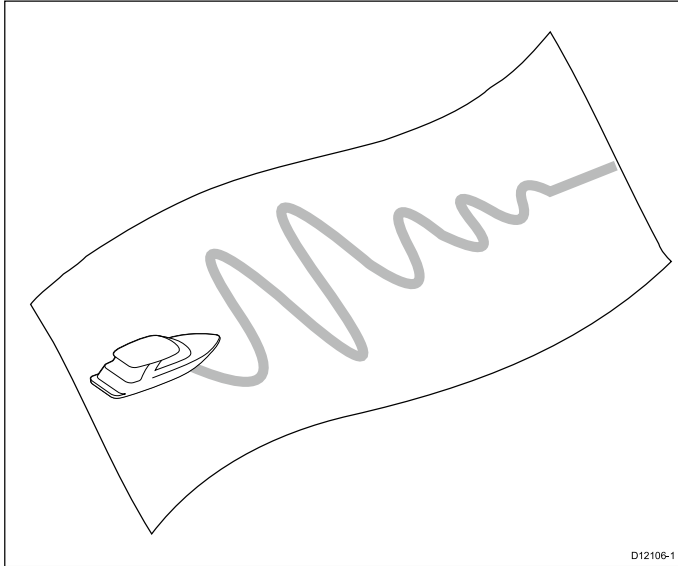

D12106-1

Caution: Autolearn

Please ensure sufficient free space ahead.
(Minimum 100x500m long & significantly more for a high speed vessel.)

Performing Auto learn

Auto learn is available from the Sea trial wizard, or from the **Commissioning menu**.

Maintain a normal cruising speed (at least 3 kts) throughout the auto learn process.

1. Ensure there is sufficient free water in front of the vessel and select **continue**.
A warning message is displayed.
2. Select **Continue** or press the **Ok** button.
A warning message will be displayed letting you know that the vessel will zigzag and make Sudden SHARP TURNS.
3. Remove your hands from the wheel and press **Auto** to begin.
During this procedure the autopilot will progress through the required steps.
4. If 'PASS' is displayed then select **Continue** or press the **Ok** button to return to manual helm control.
The autopilot will be placed in Standby mode. You have successfully completed the commissioning process for your SmartPilot system.
5. If 'FAIL' is displayed after completion of the Auto learn process then select **Continue** or press the **Ok** button.
The Auto learn retry message is displayed.
6. You can retry the Auto learn process by selecting **Yes** or to cancel select **No**.

Note: The Sea trial wizard can be cancelled at any time by pressing the **Standby** button.

Caution: System changes

Any additional changes you make to your system settings may require you to repeat the calibration process.

8.10 Checking autopilot operation

After completing calibration, check the basic autopilot operation, as follows:

1. Steer onto a compass heading and hold a steady course at normal cruising speed. If necessary, steer the vessel manually for a short time to check how the vessel steers.
2. Ensure it is safe to engage the autopilot, then press **AUTO** to lock onto the current heading. The autopilot should hold a constant heading in calm sea conditions.
3. Use **-1**, **+1**, **-10** and **+10** or the **ROTARY** controller, to see how the SmartPilot alters the course to port and starboard.
4. Press **STANDBY** to return to manual steering.

Checking rudder gain

To determine whether the rudder gain is set correctly, carry out the following test:

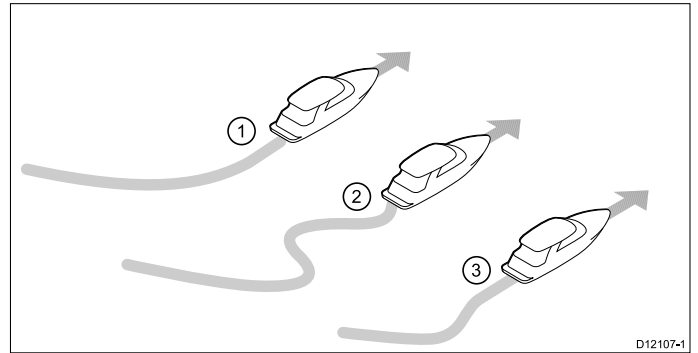

D12107-1

Item	Description
1.	Rudder gain too low
2.	Rudder gain too High
3.	Correct rudder gain

1. Ensure you have set the autopilot response to level 5.
 2. Drive your vessel at a typical cruising speed in clear water.
It is easier to recognize the steering response in calm sea conditions where wave action does not mask steering performance.
 3. Press **AUTO** to enter Auto mode, then alter course by 40°:
 - This course change should result in a crisp turn followed by an overshoot of no more than 5°, If the rudder gain is adjusted correctly.
 - If the course change causes a distinct overshoot (more than 5°) and/or there is a distinct 'S' in the course the rudder gain is too high.
 - If the vessel's performance is sluggish and it takes a long time to make the 40° turn, with no overshoot the rudder gain is too low.
- If necessary, adjust the rudder gain.

Checking counter rudder

Counter rudder is the amount of rudder your autopilot applies to try to prevent your vessel from veering off course. Higher counter rudder settings result in more rudder being applied.

To check the counter rudder setting:

1. Ensure you have set the autopilot response to level 5.
2. Drive your vessel at a typical cruising speed in clear water.
3. Press **AUTO** to switch the autopilot to Auto mode, then make a 90° course change:
 - When rudder gain and counter rudder are both set correctly, the vessel performs a smooth continuous turn with minimal overshoot.
 - If the counter rudder is too low, the vessel will still overshoot.
 - If counter rudder is too high, the vessel will 'fight' the turn and make a series of short, sharp turns. This results in a very 'mechanical' feel as the vessel changes course.

If necessary, adjust the counter rudder.

4. If necessary, adjust the counter rudder setting.

Counter Rudder is available from the Drive Settings menu:

Menu > Set-up > Autopilot Calibration > Drive Settings > Counter Rudder.

Rudder Damping

If the autopilot is 'hunting' (i.e. continuously moving the steering backwards and forwards by small amounts) when trying to position the rudder, the rudder damping setting will require adjustment to minimize this.

Increasing the rudder damping value reduces hunting. The rudder damping value should be increased 1 level at a time until the autopilot stops hunting. Always ensure the lowest acceptable value is used.

If required the Rudder Damping setting can be adjusted from the Drive Settings menu: **Menu > Set-up > Autopilot Calibration > Drive Settings > Rudder Damping.**

AutoTrim settings

AutoTrim determines how quickly the autopilot applies 'standing helm' to correct for trim changes, caused, for example, by changes in the wind load on the superstructure, or an imbalance of engines. Increasing the AutoTrim level reduces the time the autopilot takes to return to the correct course, but makes the vessel less stable. If the autopilot:

- Gives unstable course keeping and the vessel 'snakes' around the desired course, decrease the AutoTrim level.
- Hangs off course for excessive periods of time, increase the AutoTrim level.

Chapter 9: Pilot modes

Chapter contents

- [9.1 Standby on page 54](#)
- [9.2 Auto on page 54](#)
- [9.3 Mode menu on page 55](#)
- [9.4 Patterns on page 55](#)
- [9.5 Track mode on page 56](#)
- [9.6 Wind vane mode \(Sailing boats only\) on page 58](#)
- [9.7 Power steer on page 60](#)
- [9.8 Jog steer \(tiller pilots only\) on page 60](#)
- [9.9 Shortcut key on page 61](#)

9.1 Standby

In Standby you have manual control of the helm and the display shows the vessel's current compass heading.

You can disengage from Auto or any autopilot mode at any time by pressing the **STANDBY** button.

9.2 Auto

Caution: Maintain a permanent watch

Automatic course control makes it easier to steer your vessel, but it is NOT a substitute for good seamanship. ALWAYS maintain a permanent watch by the helm.

Steering automatically to a heading

You can use your autopilot system to steer automatically towards a heading.

1. Steady the vessel on the required heading.
2. Press **AUTO**.
The autopilot is now in AUTO mode and will steer to the chosen heading, shown on the display.
3. You can return to manual steering at any time by pressing **STANDBY**.

Changing course in auto mode

To change course whilst in AUTO mode:

1. Use the **-1** and **-10** button, or turn the rotary controller anticlockwise to change the vessel's course to port.
Pressing **-1** button will increment the course to port by 1° and **-10** will increment by 10°.
Turning the rotary controller 1 click anticlockwise will increment the course to port by 1° .
 2. Use the **+1** and **+10** buttons, or turn the rotary controller clockwise to change the vessel's course to starboard.
Pressing **+1** button will increment the course to starboard by 1° and **+10** will increment by 10°.
Turning the rotary controller 1 click clockwise will increment the course to Starboard by 1° .
- e.g. pressing the **-1** button four times, or turning the rotary 4 clicks anticlockwise will result in a 4° course change to port.

9.3 Mode menu

Pilot modes are accessed from the Mode menu. The available modes are determined by the autopilot system and the selected vessel hull type.

The modes available are shown below.

	Evolution	SPX SmartPilot
Pattern	Power vessel	Motor and Fishing vessels
Track	all	all
Wind vane	Sailing vessel only	Sailing vessel only
*Power Steer	p70R and joystick only	p70R and joystick only

Note:









- * Power steer mode is only available on vessels fitted with a rudder reference transducer.
- ** Wind vane mode is only available if there is a connect source of wind data.

The mode menu also provides a shortcut key option that enables a mode to be assigned to the **Left Soft** button (The default option is Track).

9.4 Patterns

A number of pre-set fishing patterns are available which can be used with their default settings or adjusted to your own preference.

The following patterns are available:

Pattern	Adjustment	Icon
Circle	Direction	
	Radius	
Zig Zag	Direction	
	Angle	
	Length	
Cloverleaf	Direction	
	Radius	
Spiral	Direction	
	Radius	
	Increment	
Circle against	Direction	
	Radius	
	Distance	
Figure 8	Direction	
	Radius	
Pattern search	Direction	
	Width	
	Height	
	Width increment	
	Height increment	
180 turn	Direction	
	Radius	
Box search	Direction	
	Width	
	Height	

Using a fishing pattern

In order to use a fishing pattern:

1. Press the **RIGHT SOFT** button to open the menu.
2. Using the **UP** and **DOWN** buttons highlight **Mode** and press **SELECT**.
3. Using the **UP** and **DOWN** buttons highlight **Pattern** and press **SELECT**.
4. Using the **UP** and **DOWN** buttons highlight the fishing pattern you wish you use and press **SELECT**.
5. The pattern settings screen shall be displayed, showing the parameters currently set for the selected pattern. If you want to change any of the parameters:
 - i. Select the parameter you want to change, then press **EDIT**.
 - ii. Use the **UP** and **DOWN** buttons to set the value you want, then press **SAVE** to save the setting and return to the Pattern settings screen.
 - iii. Repeat steps i and ii as necessary, for the other parameters.
6. When all parameters are set as required, and with the pattern settings screen displayed, press **AUTO**. The autopilot then steers the boat over the fishing pattern you selected.

To return to manual steering at any time, press **STANDBY**.

The 2 most commonly used fishing patterns are available from the **Mode** menu as **Pattern 1** and **Pattern 2**, you may select and then complete steps 5 and 6 above to quickly use your favorite patterns.

9.5 Track mode

You can use track mode to automatically steer your vessel.

In Track mode, the autopilot automatically steers your vessel to a target waypoint or along a route plotted on your multifunction display. It makes any course changes necessary to keep your vessel on course, automatically compensating for tidal streams and leeway.

Track mode is available only if you have connected the autopilot to a suitable multifunction display with autopilot control enabled.

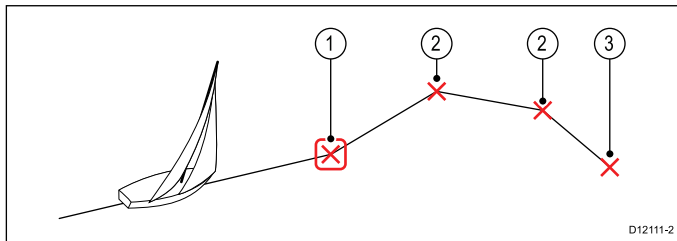

Item	Description
1	Current goto / waypoint
2	Subsequent waypoints in a route
3	Final waypoint in route

Using track mode

Start with your connected chartplotter following a route.

From the menu:

1. Select **Mode**.
2. Select **Track**.
The display will show the bearing to the next planned waypoint, and the direction in which the vessel will turn onto the track line.
3. If it is safe for the vessel to turn onto the new course, select **Track**.
The autopilot turns your vessel onto the new course with the display showing the heading required for the correct track.

Note: If the vessel is more than 0.3 nm from the track, the Large Cross Track Error warning will sound.

Waypoint arrival circle

The Waypoint Arrival Circle is a boundary line placed around the actual waypoint which, when reached triggers the waypoint arrival alarm. As the alarm is triggered by the waypoint arrival circle and not the waypoint your vessel may still be some distance from the actual waypoint when the alarm sounds. The size of the waypoint arrival circle can be customized, if the arrival circle is changed so that the radius is 0.3 nm or greater from the waypoint this can result in a cross track error alarm.

Waypoint arrival circle

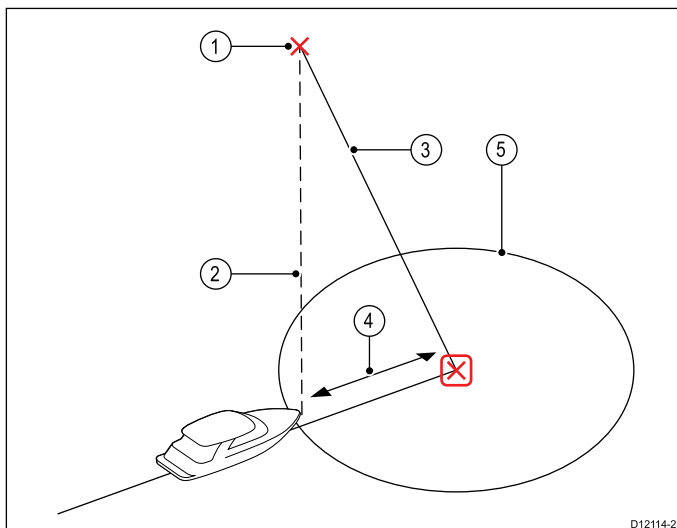

Item	Description
1	Next waypoint
2	Bearing to next waypoint
3	Track line
4	Cross track error
5	Waypoint arrival circle

Waypoint arrival

As the boat arrives at the target waypoint arrival circle the multifunction display will select the next target waypoint and transmit this to the autopilot. A Waypoint Advance warning is displayed that will identify the bearing to the next waypoint and the direction the boat will turn to acquire the new track.

Arriving at a waypoint and waypoint advance

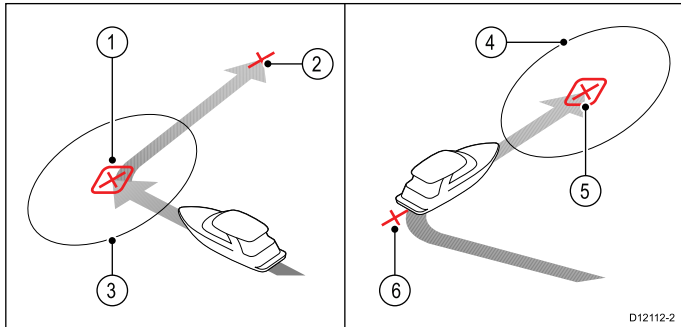

Item	Description
1	Target waypoint
2	Next waypoint
3	Waypoint arrival circle
4	Next target waypoint
5	Next waypoint arrival circle
6	Previous waypoint

Waypoint advance warning

The autopilot activates the Waypoint Advance warning in track mode whenever the target waypoint name changes. This occurs when:

- you select automatic acquisition by pressing **Track** from Auto.
- you request waypoint advance by pressing **Track** for 1 second in track mode (with SeaTalk navigators only).
- the boat arrives at the target and the navigator accepts the next waypoint.
- you activate the Man Overboard (MOB) function.

When the warning sounds, the autopilot continues on its current heading but displays:

- the bearing to the next waypoint.
- the direction the boat will turn to take up that bearing.

Arriving at a waypoint

As you approach each waypoint, an alarm sounds and a warning is displayed:

When the waypoint arrival warning is displayed:

1. Check that it is safe to turn onto the new heading.
2. If it is NOT safe or you do not want to advance to the next waypoint you can:
 - i. Select **CANCEL** or **Auto** to remain on the same heading, or
 - ii. Select **Standby** to return to manual steering.
3. If it is safe select **TRACK** to accept the new heading and proceed to the next waypoint.

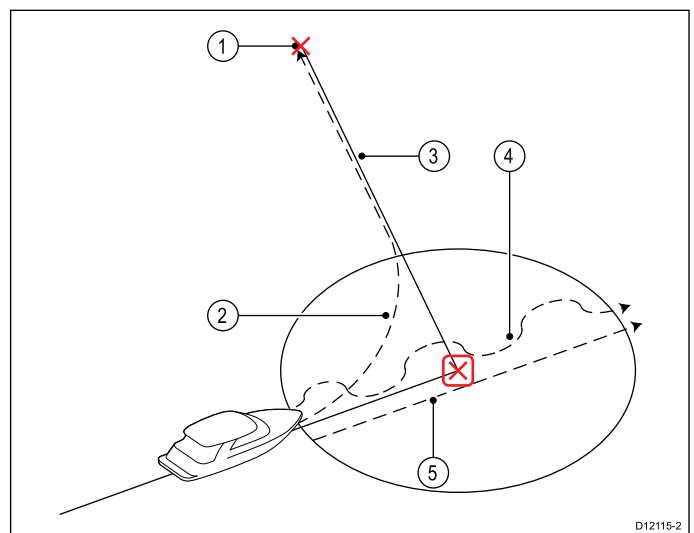

Item	Description
1	Next waypoint
2	Track — Track to next waypoint
3	Track line
4	Standby (manual control)
5	Auto or Cancel maintain current locked heading

Note: If you do not press **Track** to accept the Waypoint Advance, the autopilot will maintain the current heading and continue sounding the warning.

Cross track error

Cross track error (XTE) is the distance between the current position and a planned track line.

There are a number of reasons why you may have a cross track error (XTE), for example:

- Pressing the track button at a position some distance from the route.
- Course change to avoid an obstacle.
- Waypoint arrival under certain conditions.

If the cross track error is greater than 0.3 nm, the SmartPilot will sound the Large Cross Track Error warning and show whether you are to the port (Pt) or starboard (Stb) of the planned track.

Example 1

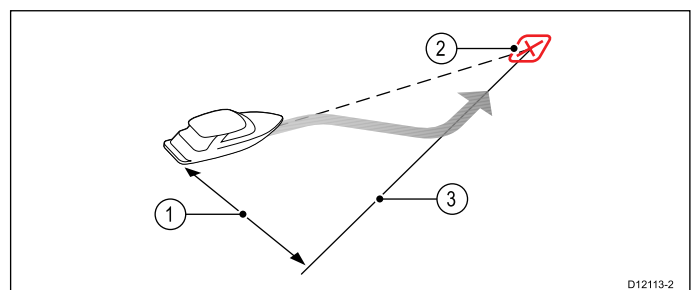

Example 1 shows the course correction which will be a turn away from the actual waypoint in order to reacquire the track line.

Item	Description
1.	Cross track error
2.	Target waypoint
3.	Track line

Note: The cross track error alarm will continue to display and sound until it is reduced to less than 0.3Nm.

Caution: Cross track error correction

When returning to TRACK mode the autopilot will correct the XTE in order to keep to the defined track leg. The direction of turn may not coincide with the bearing to waypoint and may be different from that expected.

Route completion

The autopilot displays the Route Complete warning when you have reached the last waypoint on a route.

Note: The 'Route Complete' alarm only sounds and displays in conjunction with a multifunction display.

Leaving track mode

To leave Track mode:

1. Press **AUTO** to return to Auto mode (autopilot control), or.
2. Press **STANDBY** to return to Standby mode (manual steering).

9.6 Wind vane mode (Sailing boats only)

When the autopilot is in Wind Vane mode it uses the wind angle as the primary heading reference. As changes in the true or apparent wind angle occur, it adjusts the locked heading to maintain the original wind angle.

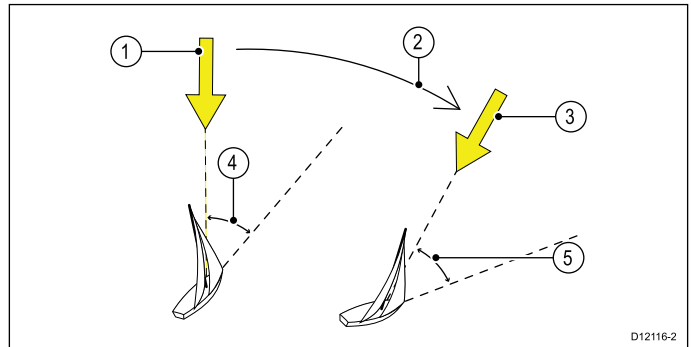

Item	Description
1	Wind direction
2	Wind shift
3	New wind direction
4	Relative wind angle
5	Vessel turns to maintain same relative wind angle

You can only select **Wind Vane** mode if the autopilot is receiving suitable SeaTalk, SeaTalk^{ng}, or NMEA 2000 wind direction data.

Autopilots can maintain a course relative to either an apparent or true wind angle in Wind Vane mode. The default setting is Apparent wind. If required, you can change this to True wind in the Sail Boat Settings menu: **Menu > Set-up > Autopilot Calibration > Sail Boat Settings > Wind Type.**

Using wind vane mode

You can select **Wind vane** mode from either **STANDBY** or **AUTO** mode:

1. Steady the vessel onto the required wind angle.
2. Select **Wind vane** mode:
 - i. Wind vane mode can be selected by pressing the **Auto** and **Standby** buttons together, or
 - ii. selecting **Wind vane** mode from the modes menu: **Menu > Mode > Wind vane.**

This will enable Wind vane mode and lock the current wind angle. The display shows the locked heading (e.g. 128°) and the wind angle (e.g. WIND 145P indicates a wind angle of 145° to port).

3. The autopilot will then adjust the vessel's heading to maintain the locked wind angle.

Adjusting the locked wind angle

1. You can adjust the locked wind angle by using the **-1**, **+1**, **-10** and **+10** buttons, or the **ROTARY** controller to change course. For example, to bear away by 10° when the boat is on a starboard tack:
 - i. press -10 to turn the boat 10° to port – the locked wind angle and locked heading will both change by 10°.
 - ii. the autopilot will then adjust the locked heading as required to maintain the new wind angle.

Note: Because turning the vessel affects the relationship between the true and apparent wind angles, you should only use this method to make minor adjustments to the wind angle. For major changes, return to **STANDBY** mode, steer onto the new heading, then reselect **Wind Vane** mode. Refer to the p70 pilot controller installation instruction for the procedure for changing the wind reference between True and Apparent.

Leaving wind vane mode

To leave wind vane mode:

1. Press **AUTO** to return to Auto mode (autopilot control), or.
2. Press **STANDBY** to return to Standby mode (manual steering).

Wind trim

In Wind Vane mode the autopilot uses Wind Trim to eliminate the effects of turbulence and short term wind variations. This provides smooth and precise performance with minimal power consumption. You can adjust the wind response (Wind Trim) level in **Sail boat settings** menu **Main menu > Set up > Autopilot calibration > Sailboat settings** to control how quickly the autopilot responds to changes in the wind direction. Higher wind trim settings will result in a pilot that is more responsive to wind changes.

Wind shift warning

If the autopilot detects a wind shift of more than 15° it will sound the wind shift warning and display the WIND SHIFT message.

Responding to the wind shift warning

1. To cancel the warning, and retain the existing wind angle and heading, press **Cancel**.
2. Alternatively, to cancel the warning and return to the previous heading:
 - i. adjust the locked wind angle using the **-1**, **+1**, **-10** and **+10** buttons or the **Rotary** controller.
 - ii. press **Standby** to return to manual steering, steer onto the required heading, and press **Cancel** to return to Wind Vane mode with the new wind angle.

Using AutoTack in wind vane mode

The autopilot has a built in automatic tack facility (AutoTack) that turns your vessel "relative" to the wind angle you're currently on, and it tacks the vessel to put you on the opposite relative wind angle.

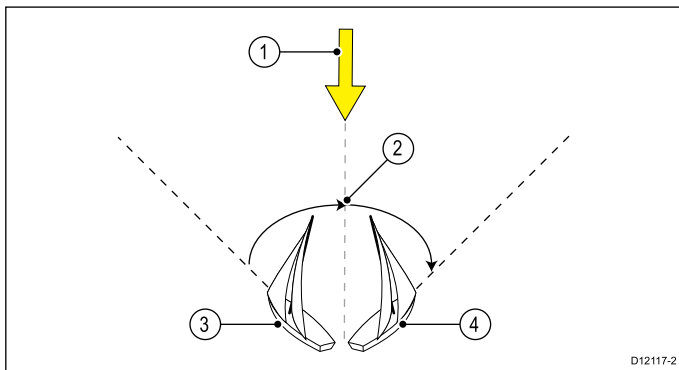

Item	Description
1	Starting position
2	Tack
3	Wind direction
4	Final position

AutoTack is always relative to wind angle and is not adjustable.

In Wind Vane mode:

1. Using a p70:
 - i. Press the **-1** and **-10** buttons at the same time to Tack to port.
 - ii. Press the **+1** and **+10** buttons at the same time to Tack to starboard.
2. Using a p70R or a p70:
 - i. Select **Tack Port** from the main menu to Tack to port.
 - ii. Select **Tack Starboard** from the main menu to Tack to Starboard.
- 3.

When you AutoTack in wind vane mode, the boat turns through the AutoTack angle. The autopilot will then trim the heading to mirror the locked wind angle from the previous tack.

Operating hints for wind vane mode

- Always trim your sails carefully to minimize the amount of standing helm.
- Reef the headsail and mainsail a little early rather than too late.
- In Wind Vane mode the autopilot will react to long-term wind shifts, but will not correct for short-term changes such as gusts.
- In gusty and unsteady inshore conditions, it is best to sail a few degrees further off the wind so that changes in wind direction can be tolerated.
- Avoid using Auto Tack in conditions where the wind may shift suddenly.

Caution: Allow time

Allow time for course changes

Caution: Major course changes

When making major course changes, the trim on the boat may change substantially. Due to this, the autopilot may take some time to settle accurately onto the new course.

Accidental gybes

The gybe inhibit feature stops the vessel from turning away from the wind if you accidentally AutoTack in the wrong direction.

Note: For the gybe inhibit feature to work, the autopilot needs suitable wind data.

With gybe inhibit set to **Prevent Gybe**:

- you will be able to perform an AutoTack through the wind.
- the autopilot will prevent the boat from performing an AutoTack away from the wind.

With gybe inhibit set to **Allow Gybe**:

- you can perform an AutoTack through or away from the wind.

Note: Gybe inhibit feature can be changed from the Sail Boat Settings menu: **Menu > Set-up > Autopilot Calibration > Sail Boat Settings > Gybe Inhibit** .

9.7 Power steer

Power steer mode enables you to use the rotary controller of the p70r or a connected joystick to directly steer the vessel on manual heading.

Power steer has 2 options:

- Proportional
 - The rudder will behave in proportion to the movement of the rotary control or joystick.
- Bang Bang (Joystick only)
 - The rudder will move, and stay in the direction the joystick is moved.

Engaging power steer mode

To engage **Power steer** mode:

1. Go to the **Mode menu** found in **Main menu > Mode**.
2. Highlight **Power steer** and press **SELECT**.

You can change the type of steering at any time i.e. Proportional or Bang Bang by going to the **Power steer** settings in the **Drive settings** menu: **Main menu > Set up > Auto pilot calibration > Drive settings > Power steer**.

Note: In order to use Bang Bang mode a connected joystick is required, the p70r rotary will only perform in Proportional mode.

9.8 Jog steer (tiller pilots only)

If you have a tiller drive installed on a SeaTalk network, your vessel you can use the pilot controller to operate the ram in Jog steer mode.

Jog steer mode enables you to use the pilot controllers **-1**, **+1**, **-10**, **+10** buttons, or the **ROTARY** controller to move the ram in and out to aid connecting and disconnecting the ram.

Note: Jog Steer can only be used whilst your vessel is in **STANDBY**.

Using jog steer (tiller drives only)

1. Ensure your vessel pilot is in **STANDBY** mode.
2. Use the **-1** and **-10** buttons, or turn the rotary controller anticlockwise to retract the ram.
3. Use the **+1** and **+10** buttons, or turn the rotary controller clockwise to extend the ram.

9.9 Shortcut key

When in pilot view you can assign pilot modes to the **LEFT SOFT** button as a shortcut depending on which vessel type has been set up.

The following pilot modes can be assigned as shortcuts:

- Track (default) — All vessels
- Pattern — Power and fishing vessels
- Power steer — All vessels (Rotary only)
- Wind vane — Sailing vessels

Assigning the shortcut key

In order to assign a pilot mode as a shortcut mapped to the **LEFT SOFT** button follow the steps below:

1. Navigate to the **Shortcut** menu: **Menu > Mode > Shortcut**.
2. Select the required pilot mode.
3. Press **SAVE**.

Chapter 10: Pilot views

Chapter contents

- [10.1 Available pilot views on page 64](#)
- [10.2 Graphical view on page 64](#)
- [10.3 Large view on page 65](#)
- [10.4 Standard view on page 65](#)
- [10.5 Multiple view on page 66](#)
- [10.6 2D View on page 66](#)
- [10.7 Setting the pilot view on page 67](#)
- [10.8 Setting up data boxes on page 67](#)

10.1 Available pilot views

Pilot views are used to display course and system data on the pilot controller's display screen.

The Available Pilot views are:

- Graphical
- Large (default)
- Standard
- Multiple
- 2D View

10.2 Graphical view

The Graphical displays a partial compass

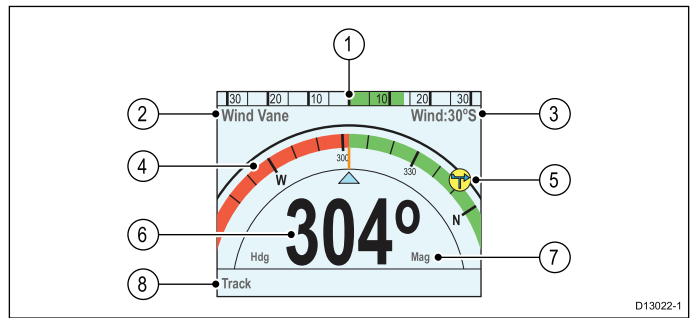

1	Rudder position
2	Pilot Mode
3	<ul style="list-style-type: none"> • Locked wind angle — Wind Vane • Pattern symbol — Pattern • Power Steer symbol — Power Steer
4	Partial compass
5	Wind direction indicator
6	<ul style="list-style-type: none"> • Current heading — Standby and Power Steer • Locked heading — Auto, Wind Vane and Pattern
7	Heading <ul style="list-style-type: none"> • Magnetic • True <p>The type of heading is determined by the language selection during the start up wizard.</p>
8	Shortcut key — Left Soft button <ul style="list-style-type: none"> • Track (default) • Pattern • Wind Vane

Initiating Track when the Pilot View is set to Graphical will display the rolling road view.

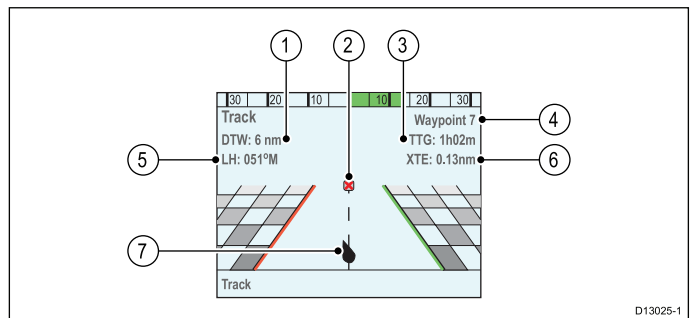

1	DTW — Distance To Waypoint
2	Destination waypoint
3	TTG — Time To Go
4	Destination waypoint name
5	Locked Heading
6	XTE — Cross Track Error
7	Vessel position

10.3 Large view

The Large view has been optimized to provide the largest possible sized text for heading data.

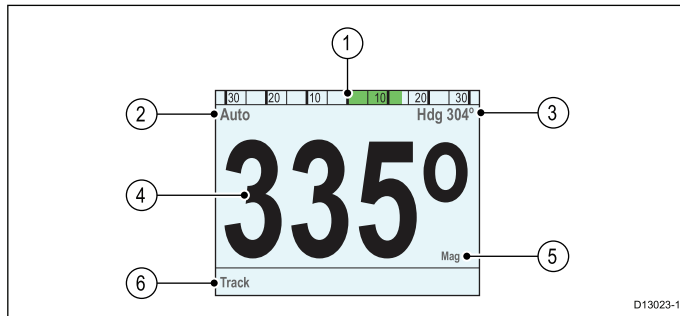

1	Rudder position
2	Pilot Mode
3	<ul style="list-style-type: none"> • Current Heading — Auto • Destination waypoint name — Track • Locked wind angle — Wind Vane • Pattern symbol — Pattern • Power Steer symbol — Power Steer
4	Heading <ul style="list-style-type: none"> • Current Heading — Standby and Power Steer • Locked Heading — Auto, Track, Wind Vane and Pattern
5	Heading <ul style="list-style-type: none"> • Magnetic • True <p>The type of heading is determined by the language selection during the start up wizard.</p>
6	Shortcut key — Left Soft button <ul style="list-style-type: none"> • Track (default) • Pattern • Wind Vane

10.4 Standard view

The Standard view provides large sized heading data combined with data boxes which provide further information.

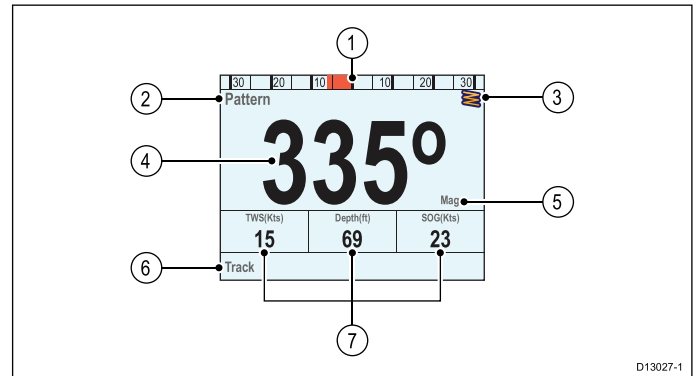

1	Rudder position
2	Pilot Mode
3	<ul style="list-style-type: none"> • Current Heading — Auto • Destination waypoint name — Track • Locked wind angle — Wind Vane • Pattern symbol — Pattern • Power Steer symbol — Power Steer
4	Heading <ul style="list-style-type: none"> • Current Heading — Standby and Power Steer • Locked Heading — Auto, Track, Wind Vane and Pattern
5	Heading <ul style="list-style-type: none"> • Magnetic • True <p>The type of heading is determined by the language selection during the start up wizard.</p>
6	Shortcut key — Left Soft button <ul style="list-style-type: none"> • Track (default) • Pattern • Wind Vane
7	Data Boxes x 3 <ul style="list-style-type: none"> • TWS (default) • Depth (default) • SOG (default)

10.5 Multiple view

The Multiple view includes multiple data boxes for displaying information.

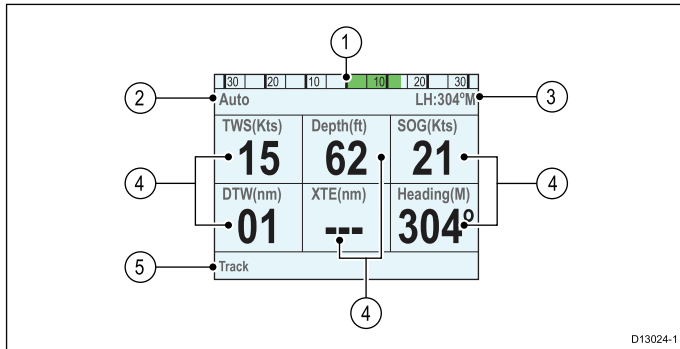

D13024-1

1	Rudder position
2	Pilot Mode
3	<ul style="list-style-type: none"> • Current Heading — Auto • Destination waypoint name — Track • Locked wind angle — Wind Vane • Pattern symbol — Pattern • Power Steer symbol — Power Steer
4	Data Boxes x 6 <ul style="list-style-type: none"> • TWS (default) • Depth (default) • SOG (default) • DTW (default) • XTE (default) • Heading (default)
5	Shortcut key — Left Soft button <ul style="list-style-type: none"> • Track (default) • Pattern • Wind Vane

10.6 2D View

The 2D view includes a full compass dial and data boxes for displaying information.

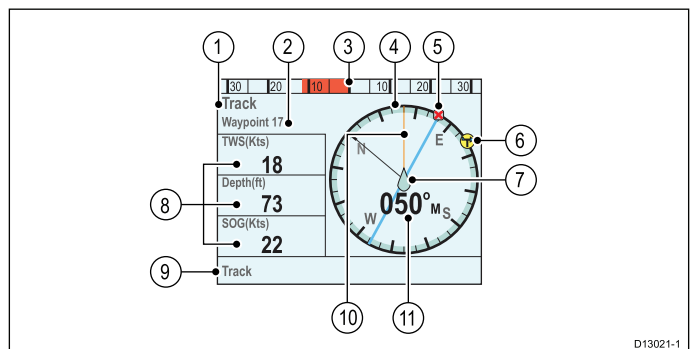

D13021-1

1	Pilot Mode
2	<ul style="list-style-type: none"> • Current Heading — Auto • Destination waypoint name — Track • Locked wind angle — Wind Vane • Pattern symbol — Pattern • Power Steer symbol — Power Steer
3	Rudder position
4	Full compass
5	Destination waypoint
6	Wind direction indicator
7	Vessel position
8	Data Boxes x 3 <ul style="list-style-type: none"> • TWS (default) • Depth (default) • SOG (default)
9	Shortcut key — Left Soft button <ul style="list-style-type: none"> • Track (default) • Pattern • Wind Vane
10	Track line
11	<ul style="list-style-type: none"> • Current heading — Standby and Power Steer • Locked heading — Auto, Wind Vane, Track and Pattern

10.7 Setting the pilot view

To set the pilot view to your desired layout:

1. Go to the **Pilot view** menu: **Main menu > Pilot view**.
2. Highlight and select **View type**.
3. Highlight the required view:
 - Graphical
 - Large
 - Standard
 - Multiple
 - 2D
4. Press **SELECT** to save the view as default.

10.8 Setting up data boxes

The Standard, Multiple and 2D Pilot views include data boxes which you can customize to display different data.

With your chosen Pilot view displayed:

1. Select **Menu**.
2. Select **Pilot View**.
3. Select **Data Boxes**.
4. Select the Data box that you want to change the data for.
A list of available data is displayed.
5. Select the relevant data type from the list.

Data boxes

The following data types are available which can be displayed in the data boxes:

Depth	
XTE	Cross track error
DTW	Distance to waypoint
BTW	Bearing to waypoint
AWA	Apparent wind angle
AWS	Apparent wind speed
TWS	True wind speed
TWA	True wind angle
COG	Course over ground
SOG	Speed over ground
Speed	
Log	
Trip	
Sea temperature	
Time	
Date	
Rate of turn	
Heading	

Chapter 11: Pilot controller alarms

Chapter contents

- [11.1 Alarms on page 70](#)

11.1 Alarms

Alarms are used to alert you to a situation or hazard requiring your attention.

Some examples of alarms are:

- Anchor alarm — Used when anchored, this alerts you to a change in depth which could mean that the chain length requires adjusting.
- Depth and speed alarms — These alarms alert you when your depth or speed moves outside of specified limits, for example a minimum depth.
- MOB (Man Overboard) alarm — Received from an MOB system.

When an alarm occurs, a message is displayed and an audible alarm may sound.



You can either:

- Silence the alarm, or
- Silence the alarm and edit the alarm settings.

Note: With the exception of the Alarm clock, Speed and Sea temperature; SeaTalk systems will only be able to switch alarms on and off, SeaTalk^{ng} systems will also be able to adjust settings.

Alarm settings

Most alarms are generated locally using specified thresholds. They are also transmitted to the SeaTalk and SeaTalk^{ng} networks for display at other compatible devices.

Alarm name	Alarm type	Description	Action
Calibration required		Indicates a pilot that has not been fully calibrated. Initiated in Standby mode, for a few seconds after initial power-up.	Dockside and Seatrial calibration needs to be undertaken. <ul style="list-style-type: none"> • Change pilot mode • Self cancelling
Off Course		Indicates Vessel is off course by more than the pre defined alarm limit. Initiated from Auto, Track & Wind modes.	<ul style="list-style-type: none"> • Change pilot mode • Change course • Correct course
Route Complete		Flagged by chart plotter / navigator when the last waypoint in a route has been reached.	<ul style="list-style-type: none"> • Change pilot mode

Alarm name	Alarm type	Description	Action
Large Cross Track Error		Indicates cross track error (XTE) is greater than 0.3nm Initiated during Track mode or on entry to Track mode from any other mode.	<ul style="list-style-type: none"> • Steer back manually and enter track again. • Check autopilot settings. • Reset XTE on the multifunction display.
Loss of Waypoint data		Indicates the source (e.g. chartplotter) of the waypoint data has been lost	<ul style="list-style-type: none"> • Pilot drops out of track mode and into auto mode and continues on last locked heading. •
Wind Shift		Indicates apparent wind angle has changed by more than 15 degrees. Initiated from Wind vane mode only.	<ul style="list-style-type: none"> • Change pilot mode. • Change course. • Reduction of change in wind angle.
Auto release	Safety Alarm	Appears when the user has taken back control of the steering whilst in an engaged mode (Auto, Track, etc) using the fly-by-wire steering wheel.	<ul style="list-style-type: none"> • Pilot drops to standby and alarm times out after 10 seconds.
Drive stopped	Safety Alarm	Indicates a rudder stall condition has persisted or that the power has been removed from the drive unit. Initiated in Auto, Track & Wind modes.	<ul style="list-style-type: none"> • Check output from SPX, drive unit and connections. • Pilot drops to standby and alarm times out after 10 seconds.
No Control Head	Safety Alarm	The course computer has lost communications with the Pilot controller, this alarm is generated by the course computer.	<ul style="list-style-type: none"> • Check connections for short or open circuit. • Check system for device fault. • Pilot drops to standby and alarm times out after 10 seconds.

Alarm name	Alarm type	Description	Action
SeaTalk fail	Safety Alarm	Total SeaTalk data transmission problem.	<ul style="list-style-type: none"> • Check connections for short or open circuit. • Check system for device fault. • Pilot drops to standby and alarm times out after 10 seconds.
EEPROM corruption	Safety Alarm	A corruption of critical configuration data has occurred.	<ul style="list-style-type: none"> • Pilot drops to standby and alarm times out after 10 seconds.
No Pilot	Safety Alarm	The Pilot controller has lost communications with the course computer; this alarm is generated by the Pilot controller.	<ul style="list-style-type: none"> • Check Seatalk or Seatalk^{ng} bus wiring between SPX and Pilot controller. • Check that the course computer is powered up.
No Compass	Safety Alarm	Compass is not connected.	<ul style="list-style-type: none"> • Check connections and compass transducer.
Rate Gyro fault	Safety Alarm	The gyro sensor has failed.	<ul style="list-style-type: none"> • Internal Gyro failure, investigate fault and Consult a Raymarine Service Agent.
Current Limit	Safety Alarm	Drive overload current exceeded.	<ul style="list-style-type: none"> • Check drive unit and connections for stall or short circuit wiring • Pilot drops to standby and alarm times out after 10 seconds.
Rudder reference unit failure	Safety Alarm	Rudder Reference connection has been lost, or exceeded it's limits. Rudder reference transducer has failed while in auto. Angle is more than 50 degrees or connection to rudder reference is lost	<ul style="list-style-type: none"> • Pilot drops to standby and alarm times out after 10 seconds.
AutoLearn fail 1 (not carried out)	Safety Alarm	Autolearn has not been carried out	<ul style="list-style-type: none"> • Restart AutoLearn.

Alarm name	Alarm type	Description	Action
AutoLearn fail 2 (Manual intervention)	Safety Alarm	Manual intervention during autolearn	<ul style="list-style-type: none"> • Restart AutoLearn.
AutoLearn fail 3 (Compass or drive error)	Safety Alarm	Investigate compass or drive fault	<ul style="list-style-type: none"> • Restart AutoLearn.
AutoLearn fail 4	Safety Alarm	AutoLearn has failed due to compass or drive error.	<ul style="list-style-type: none"> • Restart AutoLearn.
AutoLearn fail 5	Safety Alarm	AutoLearn has failed due to motor going into current limit.	<ul style="list-style-type: none"> • Restart AutoLearn.
AutoLearn fail 6	Safety Alarm	AutoLearn has failed as boat went into spin i.e. motor did not drive the rudder back to opposite side.	<ul style="list-style-type: none"> • Restart AutoLearn.
Turn rate too high	Safety Alarm	Indicates an excessive rate of turn whilst linearizing the fluxgate compass. Initiated in Calibration mode.	<ul style="list-style-type: none"> • Reduce rate of turn.
Power & Motor Cables are swapped	Safety Alarm	If the motor pair and the power pair are swapped.	<ul style="list-style-type: none"> • Swap motor and power wires at the course computer
Low battery	Alarm	Will appear when Battery goes below threshold set. 10 V (default)	<ul style="list-style-type: none"> • Check batteries or power supply • Will silence if current goes above threshold. • Press cancel.
No Navigation data	Alarm	Indicates absence of one of the following primary control data items: <ul style="list-style-type: none"> • Compass – Auto, Track & Wind modes. • XTE – Track mode. • Wind angle – Wind vane mode. 	<ul style="list-style-type: none"> • Check the correct navigation data is available for the mode selected. • Check the data source.
Pilot start up	Alarm	Will display start up for 20 seconds everytime the pilot is powered up	<ul style="list-style-type: none"> • Self cancelling.

Alarm name	Alarm type	Description	Action
Waypoint advance	Alarm	Indicates change in waypoint name or ID and direction to turn to new waypoint. Initiated in Track mode.	<ul style="list-style-type: none"> • Change pilot mode. • Accept new waypoint route.
No Wind data	Alarm	SmartPilot is in Wind Vane Mode but has not received Wind Angle data for 30 seconds.	<ul style="list-style-type: none"> • Check wind data source and connections. • Pilot drops out of wind vane mode and reverts to auto mode. • Change pilot mode
No speed data	Alarm	Speed data has stopped .	<ul style="list-style-type: none"> • Check Seataalk connections for short or open circuit. • Check system for Seataalk device fault.
SeaTalk 1 fail	Alarm	SeaTalk channel 1 has a communication problem.	<ul style="list-style-type: none"> • Change pilot mode.
SeaTalk 2 fail	Alarm	SeaTalk channel 2 has a communication problem.	<ul style="list-style-type: none"> • Change pilot mode.
Drive short	Warning	Indicates a short circuit in the drive unit	<ul style="list-style-type: none"> • Pilot will power down • User to fix short circuit
Clutch short	Warning	Indicates a short circuit in the Clutch	<ul style="list-style-type: none"> • Check clutch connections at SPX and drive unit • . Check drive unit clutch. • User to fix short circuit
Solenoid short	Warning	Indicates a short circuit in the solenoid	<ul style="list-style-type: none"> • Pilot will power down • User to fix short circuit

Chapter 12: Set up menu options

Chapter contents

- [12.1 Set up menu on page 74](#)
- [12.2 Autopilot calibration menu on page 74](#)
- [12.3 System set-up menu on page 81](#)
- [12.4 User preferences menu on page 82](#)
- [12.5 Simulator on page 83](#)
- [12.6 Factory reset on page 83](#)
- [12.7 Diagnostics on page 84](#)

12.1 Set up menu

The set up menu provides a range of tools and settings to configure the pilot controller.

Menu item	Description	Options
Auto Pilot calibration	Pilot commissioning / calibration settings	SeaTalk^{ng} <ul style="list-style-type: none"> • Vessel settings. • Drive settings. • Sailboat settings. • Commissioning. SeaTalk <ul style="list-style-type: none"> • User settings. • Dealer settings. • Seatrial calibration.
User preferences	Set user preferences such as: Time & Date, Units of measurement, Language, Vessel type, Vessel details, and Variation.	User preferences menu.
System set up	Set system grouping, display and system color and brightness, Multiple data sources and about system set up.	System set up menu.
Simulator	Enables or disables simulator mode, which allows you to practice operating your instrument display without any data from any other external unit.	<ul style="list-style-type: none"> • On • Off
Factory reset	Delete user settings and Restore unit to factory default settings.	<ul style="list-style-type: none"> • Yes • No
Diagnostics	Information About the display and system and key beep on / off setting.	<ul style="list-style-type: none"> • Yes • No

12.2 Autopilot calibration menu

The Autopilot Calibration menu options are determined by the connected autopilot system.

Note: Not all options are available when **Calibration Lock** is turned On.

Note:

- *SPX and SeaTalk SmartPilots only.
- **Evolution autopilots only.

Menu	Options
Vessel Settings	<ul style="list-style-type: none"> • Vessel Hull Type • Drive Type • *Cruise Speed • Compass Offset • *Latitude Compass Damping • Calibration Lock
Drive Settings	<ul style="list-style-type: none"> • *Rudder Gain • *Response Level • *Counter Rudder • Rudder Damping • *Auto Trim • Auto Turn • **Power Steer • Reverse Rudder Ref. • *Off Course Alarm • *Turn Rate Limit • Motor Phasing • Rudder Limit • **Rudder Offset • Hard Over Time
Commissioning	<ul style="list-style-type: none"> • Dockside Wizard • *Sea Trial Wizard • *Motor Phasing • *Swing Compass • *Auto Learn • Align Compass GPS • *Align Compass • Pilot Factory Reset • **Restart Compass • **Compass Lock • **Debug Level

Vessel Settings

Vessel settings are dependant on connected autopilot system and vessel drive type.

The Vessel settings menu can be accessed from: **Menu > Set-up > Autopilot Calibration > Vessel Settings.**

Note: When connected to a SeaTalk system the vessel settings listed below are part of the **Dealer settings** menu, **Menu > Set-up > Autopilot Calibration > Dealer Settings.**

Note: Not all options are available when **Calibration Lock** is turned On.

Item	Description	Evolution autopilots	SeaTalk and SPX SmartPilot Options
Vessel type	The vessel type options will normally give optimum performance for typical vessels of each type. However, you may find you can improve the performance of your vessel by selecting an option for a different vessel type.	<ul style="list-style-type: none"> • Sail. • Sail (Slow turn). • Sail Catamaran. • Power. • Power (slow turn). • Power (fast turn). 	<ul style="list-style-type: none"> • Race sail. • Sail cruiser. • Catamaran. • Workboat. • RIB. • Outboard speed boat. • Inboard speed boat. • Power cruiser 1. — Vessel speeds up to 12 knots. • Power cruiser 2.— Vessel speeds up to 30 knots. • Power cruiser 3 — Vessels speeds greater than 30 knots. • Sport fishing. • Pro fishing.
Drive type	<p>List of compatible drive types. The list is dependant upon connected autopilot system.</p> <div style="border: 1px solid black; padding: 5px; margin-top: 10px;"> <p>Note: The drive type option is not available in systems comprising of an EV-2 and an ACU-300.</p> </div>	<ul style="list-style-type: none"> • Type 1 Linear — ACU-200 and ACU-400 • Type 2 Linear — ACU-400 only • Type 2 Hydraulic Linear — ACU-400 only • Type 3 Hydraulic Linear — ACU-400 only • I/O Stern — ACU-200 and ACU-400 • Wheel Drive — ACU-100, ACU-200 and ACU-400 • Tiller — ACU-100, ACU-200 and ACU-400 • CR Solenoid — auto detected — ACU-300 only (not selectable) • Sport Drive — ACU-200 and ACU-400 • Rotary Drive Type 1 — ACU-200 and ACU-400 • Rotary Drive Type 2 — ACU-400 only • Hydraulic Pump Type 1 (0.5L) — ACU-100 only • Hydraulic Pump Type 1 — ACU-200 and ACU-400 • Hydraulic Pump Type 2 — ACU-400 only • Hydraulic Pump Type 3 — ACU-400 only • Verado — ACU-200 and ACU-400 	<ul style="list-style-type: none"> • Type 1 linear • Type 2 linear • Type 3 linear • Hydraulic pump type 1 • Hydraulic pump type 2 • Hydraulic pump type 3 • Rotary drive type 1 • Rotary drive type 2 • Rotary type 1 • Rotary type 2 • I/O stern • CAN • Wheel drive. • Tiller • Sport drive • Constant running pump. • Verado
Cruise speed	Set the cruise speed to the vessel's typical cruising speed. If no speed data is available, the SmartPilot system will use the cruise speed value you set as a default.	N/A	<ul style="list-style-type: none"> • 0 to 99 Kts
Compass Offset	On systems without a GPS then the compass heading must be manually aligned to the vessels known heading.	<ul style="list-style-type: none"> • -10° to 10° 	<ul style="list-style-type: none"> • -179° to 180°

Item	Description	Evolution autopilots	SeaTalk and SPX SmartPilot Options
Latitude Compass Damping	If no valid latitude data is available, the autopilot system will use this setting which provides the necessary adaptation for higher latitudes.	N/A	<ul style="list-style-type: none"> • On • Off (default)
Auto release	<p>Auto release allows you to override the pilot by taking hold of the wheel or tiller. When you release the wheel or tiller, the pilot will return to the last locked heading.</p> <div style="border: 1px solid black; padding: 5px; margin-top: 10px;"> <p>Note: Only available on S1, S2, or S3 course computers only with drive type set to I/O stern.</p> </div>	N/A	<ul style="list-style-type: none"> • Enable (default) • Disable
Calibration lock	The calibration lock is used to lock out specific calibration settings which if changed may require recommissioning of the autopilot system. If your system has been dealer installed then the lock may be turned on.	<ul style="list-style-type: none"> • On • Off (default) 	<ul style="list-style-type: none"> • On • Off (default)

Drive settings

Drive settings are dependant on connected autopilot system.

The Drive Settings menu can be accessed from: **Menu > Set-up > Autopilot Calibration > Drive Settings.**

Note: Not all options are available when Calibration Lock is turned On.		
Item	Description	Options
*Rudder gain	Rudder gain is a measure of how much helm the autopilot will apply to correct course errors. A higher setting results in more rudder being applied. The rudder gain setting is set automatically as part of the Auto Learn process.	<ul style="list-style-type: none"> • 1 — 9
*Counter rudder	Counter rudder is the amount of rudder the autopilot system applies to try to prevent the vessel from yawing off course. A higher counter rudder setting results in more rudder being applied	<ul style="list-style-type: none"> • 1 — 9 Do not set to 0.
Rudder damping	On autopilot systems with a rudder reference transducer, you can set the rudder damping to prevent autopilot 'hunting'. Increasing the rudder damping value reduces hunting. When adjusting the value, increase the setting one level at a time until the autopilot stops hunting. Always use the lowest acceptable value. Rudder Damping	<ul style="list-style-type: none"> • 1 — 9 • 2 (default)
Rudder limit	If a rudder reference transducer is fitted, this screen is used to set the limits of the rudder control just inside the mechanical end stops, and thus avoid putting the steering system under unnecessary load. This should be set when commissioning the system. The limit should be set to approximately 5 degrees less than the maximum rudder angle. Note: If no rudder reference has been fitted you MUST ensure that adequate provision is made to prevent the steering mechanism from impacting the end stops.	<ul style="list-style-type: none"> • 10° — 40° • 30° (default)
Rudder offset	This specifies the offset from amidships (zero adjustment).	<ul style="list-style-type: none"> • -9° to 9°
Reverse rudder ref	This reverses the phase of the rudder reference display. Note: This option is not available unless you have a rudder reference transducer fitted. Note: This option is not available on SeaTalk systems, so you would need to reverse the RED and GREEN wires on the Rudder Reference connection to the course computer.	<ul style="list-style-type: none"> • Port • Starboard
*Auto Trim	The Auto Trim setting determines the rate at which the autopilot system applies 'standing helm' to correct for trim changes caused by varying wind loads on the sails or superstructure. The default Auto Trim is set as part of the Auto Learn process. If you need to change the setting, increase the Auto Trim one level at a time and use the lowest acceptable value: <ul style="list-style-type: none"> • If the autopilot system gives unstable course keeping or excessive drive activity with a change in the heel angle, decrease the Auto Trim level. • If the autopilot system reacts slowly to a heading change due to a change in the heel angle, increase the Auto Trim level. • If the Auto Trim level is too high, the vessel will be less stable and snake around the desired course. 	<p>Setting</p> <ul style="list-style-type: none"> • Off • On <p>Adjustment</p> <ul style="list-style-type: none"> • 1 — 4 1 = Slowest, 4 = Fastest • 1 (default)
Auto Turn	This setting defines the amount of course change when performing an auto turn. Note: This option cannot be changed when connected over SeaTalk. Note: This option is only available on motor vessels.	<ul style="list-style-type: none"> • 10° — 125° • 90° (default)

Item	Description	Options
Response level	This sets the default autopilot system response level setting. The response level controls the relationship between course keeping accuracy and the amount of helm / drive activity. You can make temporary changes to response during normal operation.	<p>Evolution</p> <div style="border: 1px solid black; padding: 5px; margin-bottom: 10px;"> <p>Note: On Evolution autopilots the Response level setting is available from the main menu: Menu > Response Level</p> </div> <ul style="list-style-type: none"> • Performance • Cruising • Leisure <p>SeaTalk and SPX SmartPilot</p> <ul style="list-style-type: none"> • 1 — 9 • 5 (default) • Level 1 — 3 Minimize the amount of pilot activity. This conserves power, but may compromise short-term course-keeping accuracy. • Level 4 — 6 Should give good course keeping with crisp, well controlled turns under normal operating conditions. • Level 7 — 9 Gives the tightest course keeping and greatest rudder activity (and power consumption). This can lead to a rough passage in open waters as the SPX system may 'fight' the sea.
*Off course alarm	This screen determines the angle used by the OFF COURSE alarm. The OFF COURSE alarm operates if the pilot strays off course by more than the specified angle for more than 20 seconds.	<ul style="list-style-type: none"> • 15° to 40° • 20° (default)
*Turn rate limit	This limits your vessel's rate of turn under autopilot system control. It is only effective if your speed is greater than 12 knots.	<ul style="list-style-type: none"> • 1° to 30° • 7° (default)
Power steer	<p>This screen determines the behavior of the Rotary or joystick when in power steer mode.</p> <div style="border: 1px solid black; padding: 5px; margin-top: 10px;"> <p>Note: Power Steer mode is only available if the system includes a rudder reference transducer and speed data is available</p> </div>	<ul style="list-style-type: none"> • Off • Proportional The steering will behave in proportion to the movement of the rotary controller or joystick. • Bang Bang (Joystick only) The rudder will move, and stay in the direction a joystick is moved.
Hard over time	On vessels without a rudder reference transducer, it is of critical importance to set the hard over time, to ensure accurate autopilot operation.	<ul style="list-style-type: none"> • Value is seconds <p>Default value is determined by Drive type selection.</p>

Note: * SPX and SeaTalk SmartPilots only.

Sail boat settings

These settings are only available to sail boats.

The Sail Boat settings menu can be accessed from: **Menu > Set-up > Autopilot Calibration > Sail Boat Settings.**

Note: When connected to a SeaTalk system the Sail boat settings listed below are part of the **User settings** menu: **Menu > Set-up > Autopilot Calibration > User Settings.**

Item	Description	Options
Gybe inhibit	With gybe inhibit set to allow, the autopilot will allow the vessel to tack through / into and away from the wind. With gybe inhibit set to prevent, you can only tack through / into the wind. Gybe inhibit does not effect Auto Turn	<ul style="list-style-type: none">• Allow Gybe• Prevent Gybe
Wind Trim Response	Wind trim response controls how quickly the autopilot responds to changes in the wind direction. Higher wind trim settings will result in a system that is more responsive to wind changes.	<ul style="list-style-type: none">• 1 — 9• 5 (default)
Wind Type	This option determines whether the vessel steers to apparent or true wind in Wind Vane mode.	<ul style="list-style-type: none">• True• Apparent

Note: These features are only available if wind data is available.

Commissioning menu

Commissioning menu options are dependant on connected autopilot system.

Note: Not all options are available when **Calibration Lock** is turned On.

Menu option	Description	Evolution autopilots	SeaTalk and SPX SmartPilots
Dockside Wizard	Initiates the Dockside wizard process.	Yes	Yes
Sea Trial Wizard	Initiates the Sea Trial wizard process.	N/A	Yes
Motor phasing	Initiates the motor phasing (drive check) wizard	N/A	Yes
Swing Compass	Initiates the swing compass wizard	N/A	Yes
Auto Learn	Initiates the Auto Learn process	N/A	Yes
Align Compass GPS	Initiates the align compass to GPS heading wizard	Yes	Yes
Align Compass	Manual adjustment of the compass offset	• -10° to 10°	• -179° to 180°
Pilot Factory Reset	Resets the autopilots course computer to factory default settings.	• Yes • No	• Yes • No
Debug Level	Sets the debug level value. The Debug option is only available when calibration lock is turned off.	• Level 0 to 31	N/A
Restart Compass	Restarts the compass	• Yes • Cancel	N/A
Compass Lock	Locks the compass from performing further automatic linearization.	• On • Off	N/A

User Settings

When connected to a SeaTalk autopilot system a User settings menu will be available.

The User settings menu can be accessed from: **Main Menu > Set up > Autopilot calibration > User settings**. Once entered the user settings menu will cycle through all available options. These options shall be available to users when calibration lock is turned on.

12.3 System set-up menu

The **System set-up** menu enables users to customize the following user settings:

Menu item	Description	Options
Network group	Allows adding multiple units together in a group so that when the color scheme or brightness is changed on one unit the changes are applied to all units in the group.	Predefined groups <ul style="list-style-type: none"> • None • Helm 1 • Helm 2 • Cockpit • Flybridge • Mast Undefined <ul style="list-style-type: none"> • Group-1 — Group-5
Brightness / color group	Enables synchronization of the displays brightness and color to be the same as the other units in the same group.	Sync brightness / color <ul style="list-style-type: none"> • This display • This group
Data sources	Allows you to view and select preferred data sources. <ul style="list-style-type: none"> • Select data source • Data source found • Data source details 	Select data source <ul style="list-style-type: none"> • GPS position • GPS Datum • Time & Date • Heading • Depth • Speed • Wind Data source found <ul style="list-style-type: none"> • model name — serial number Port ID Data source details <ul style="list-style-type: none"> • Device name • Serial No. • Port ID • Status or No data
About system set-up	Provides information about the System set-up menu.	

12.4 User preferences menu

The **User preferences** menu enables users to customize user settings.

Menu item	Description	Options
Time & date	These options enable you to customize the date and time format to your requirements. You can also specify a local time offset from Universal Time Constant (UTC), to compensate for any time zone difference.	Time format: <ul style="list-style-type: none"> • 24 Hour • am/pm Date format: <ul style="list-style-type: none"> • MM/DD/YYYY • DD/MM/YYYY Time offset: <ul style="list-style-type: none"> • -13 to +13 hours in 30 minute increments
Units	Enables you to specify the units used for data measurements: <ul style="list-style-type: none"> • Speed • Distance • Depth • Wind speed • Temperature • Flow rate • Heading • Pressure • Volume 	Speed: <ul style="list-style-type: none"> • Kts — knots. • MPH — miles per hour. • KPH — Kilometers per hour. Distance: <ul style="list-style-type: none"> • nm — Nautical miles. • sm — Statute miles. • km — Kilometers. Depth: <ul style="list-style-type: none"> • ft — Feet • m— Metres • Fa—Fathoms Wind speed: <ul style="list-style-type: none"> • Kts — knots. • MS — metres per second. Temperature: <ul style="list-style-type: none"> • °C — degrees centigrade. • °F — degrees fahrenheit. Flow rate <ul style="list-style-type: none"> • G/H (UK) — UK gallons per hour. • G/H (US) — US gallons per hour. • LTR/H — Liters per hour. Heading: <ul style="list-style-type: none"> • True • Mag — magnetic. Pressure <ul style="list-style-type: none"> • PSI — pounds per square inch. • BAR — bar. • KPa — Kilo pascals. Volume:

Menu item	Description	Options
		<ul style="list-style-type: none"> • GAL — (UK) — UK gallons. • GAL — (US) — US gallons. • LTR — liter.
Language	Determines the system language.	<ul style="list-style-type: none"> • Chinese • Croatian • Danish • Dutch • English — UK • English — US • Finnish • French • German • Greek • Italian • Japanese • Korean • Norwegian • Polish • Portuguese (Brazilian) • Russian • Spanish • Swedish • Turkish

12.5 Simulator

The Simulator mode enables you to practice operating your display without live data from a transducer or other connected peripherals.

The simulator mode is switched on/off in the **Simulator** option from the **Setup Menu**.

Note: Raymarine recommends that you do NOT use the simulator mode whilst navigating.

Note: The simulator will NOT display any real data, including any safety messages (such as those received from AIS units).

Note: Any system settings made whilst in Simulator mode are not transmitted via SeaTalk to other equipment.

12.6 Factory reset

Your product can be reset to factory default settings from the **Setup > Factory reset** menu.

Performing a factory reset will reset your product back to factory default settings and erase any saved data and user settings.

12.7 Diagnostics

You can access diagnostics details from the **Setup > Diagnostics** menu option and can view information relating to:

Menu item	Description	Options
About display	Allows you to view information about the instrument display you are using:	<ul style="list-style-type: none"> • Software version • Hardware version • Bootloader version • Temperature • Volts • Max. volts • Current • Max. current • Run time • Deviation (If available)
About system	Allows you to view information about products on the system you are using:	<ul style="list-style-type: none"> • Model number • Serial number • Software version • Hardware version • Volts
Key beep	Enables you to turn on and off the audible beeps when keys are pressed	<ul style="list-style-type: none"> • On • Off
Self test	The product has a built in self test which can help to diagnose faults.	<ul style="list-style-type: none"> • Memory test • Button test • Display test • Buzzer test • Illumination test

Chapter 13: Troubleshooting

Chapter contents

- [13.1 Troubleshooting on page 86](#)

13.1 Troubleshooting

The troubleshooting information provides possible causes and corrective action required for common problems associated with marine electronics installations.

All Raymarine products are, prior to packing and shipping, subjected to comprehensive test and quality assurance programs. However, if you experience problems with the operation of your product this section will help you to diagnose and correct problems in order to restore normal operation.

If after referring to this section you are still having problems with your unit, please contact Raymarine Technical Support for further advice.

Power up troubleshooting

Problems at power up and their possible causes and solutions are described here.

Problem	Possible causes	Possible solutions
The system (or part of it) does not start up.	Power supply problem.	Check relevant fuses and breakers.
		Check that the power supply cable is sound and that all connections are tight and free from corrosion.
		Check that the power source is of the correct voltage and sufficient current.

System data troubleshooting

Aspects of the installation can cause problems with the data shared between connected equipment. Such problems, their possible causes and solutions are described here.

Problem	Possible causes	Possible solutions
Instrument, engine or other system data is unavailable at all displays.	Data is not being received at the display.	Check the data bus (e.g. SeaTalk ^{ng}) wiring and connections.
		Check the overall integrity of the data bus (e.g. SeaTalk ^{ng}) wiring.
		If available refer to the reference guide for the data bus (e.g. SeaTalk ^{ng} reference manual).
	Data source (e.g. ST70 instrument or engine interface) is not operating.	Check the source of the missing data (e.g. ST70 instrument or engine interface).
		Check the power to the SeaTalk bus.
		Refer to the manufacturer's handbook for the equipment in question.
Software mismatch between equipment may prevent communication.	Contact Raymarine technical support.	
Instrument or other system data is missing from some but not all displays.	Network problem.	Check that all required equipment is connected to the network.
		Check the status of the Raymarine network Switch.
		Check that SeaTalk ^{hs} / RayNet cables are free from damage.
	Software mismatch between equipment may prevent communication.	Contact Raymarine technical support.

Miscellaneous troubleshooting

Miscellaneous problems and their possible causes and solutions are described here.

Problem	Possible causes	Possible solutions
Display behaves erratically: <ul style="list-style-type: none"> • Frequent unexpected resets. • System crashes or other erratic behavior. 	Intermittent problem with power to the display.	Check relevant fuses and breakers.
		Check that the power supply cable is sound and that all connections are tight and free from corrosion.
		Check that the power source is of the correct voltage and sufficient current.
	Software mismatch on system (upgrade required).	Go to www.raymarine.com and click on support for the latest software downloads.
	Corrupt data / other unknown issue.	Perform a factory reset. <div style="border: 1px solid black; padding: 5px; margin-top: 5px;"> <p>Important: This will result in the loss of any settings and data (such as waypoints) stored on the product. Save any important data to a memory card before resetting.</p> </div>

Chapter 14: Maintenance

Chapter contents

- 14.1 Routine equipment checks on page 92
- 14.2 Cleaning on page 92
- 14.3 Cleaning the display screen on page 93
- 14.4 Cleaning the display case on page 93
- 14.5 Cleaning the sun cover on page 94

14.1 Routine equipment checks

Raymarine strongly recommends that you complete a number of routine checks to ensure the correct and reliable operation of your equipment.

Complete the following checks on a regular basis:

- Examine all cables for signs of damage or wear and tear.
- Check that all cables are securely connected.

14.2 Cleaning

Best cleaning practices.

When cleaning this product:

- Do NOT wipe the display screen with a dry cloth, as this could scratch the screen coating.
- Do NOT use abrasive, or acid or ammonia based products.
- Do NOT use a jet wash.

14.3 Cleaning the display screen

A coating is applied to the display screen. This makes it water repellent, and prevents glare. To avoid damaging this coating, follow this procedure:

1. Switch off the power to the display.
2. Rinse the screen with fresh water to remove all dirt particles and salt deposits.
3. Allow the screen to dry naturally.
4. If any smears remain, very gently wipe the screen with a clean microfibre cleaning cloth (available from an opticians).

14.4 Cleaning the display case

The display unit is a sealed unit and does not require regular cleaning. If it is necessary to clean the unit, follow this basic procedure:

1. Switch off the power to the display.
2. Wipe the display with a clean, soft cloth (a microfibre cloth is ideal).
3. If necessary, use a mild detergent to remove grease marks.

Note: Do NOT use solvents or detergents on the screen itself.

Note: In certain conditions, condensation may appear inside the display screen. This will not harm the unit, and can be cleared by powering on the display for a short time.

14.5 Cleaning the sun cover

The supplied sun cover features an adhesive surface. In certain conditions unwanted contaminants may stick to this surface. To avoid damaging the monitor display, clean the sun cover regularly following this procedure:

1. Carefully remove the sun cover from the display.
2. Rinse the sun cover with fresh water to remove all dirt particles and salt deposits.
3. Allow the sun cover to dry naturally.

Chapter 15: Technical support

Chapter contents

- [15.1 Raymarine customer support on page 96](#)
- [15.2 Viewing product information on page 96](#)

15.1 Raymarine customer support

Raymarine provides a comprehensive customer support service. You can contact customer support through the Raymarine website, telephone and e-mail. If you are unable to resolve a problem, please use any of these facilities to obtain additional help.

Web support

Please visit the customer support area of our website at:

www.raymarine.com

This contains Frequently Asked Questions, servicing information, e-mail access to the Raymarine Technical Support Department and details of worldwide Raymarine agents.

Telephone and e-mail support

In the USA:

- **Tel:** +1 603 324 7900
- **Toll Free:** +1 800 539 5539
- **E-mail:** support@raymarine.com

In the UK, Europe, and the Middle East:

- **Tel:** +44 (0)13 2924 6777
- **E-mail:** ukproduct.support@raymarine.com

In Southeast Asia and Australia:

- **Tel:** +61 (0)29479 4800
- **E-mail:** aus.support@raymarine.com

Product information

If you need to request service, please have the following information to hand:

- Product name.
- Product identity.
- Serial number.
- Software application version.
- System diagrams.

You can obtain this product information using the menus within your product.

15.2 Viewing product information

1. From the main menu scroll to **Set Up** and press the **SELECT** key.
2. From the Set Up menu scroll to **Diagnostics** and press the **SELECT** key.
3. Select **About system**.

A range of information is displayed, including the software version and Serial number.

Chapter 16: Technical specification

Chapter contents

- [16.1 Viewing angle on page 98](#)
- [16.2 Technical specification on page 98](#)

16.1 Viewing angle

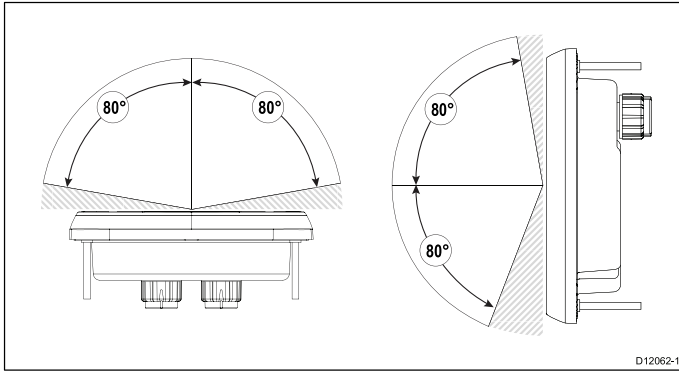

Note: The viewing angles stated above were taken using internationally agreed standards and should be used for comparison purposes only. Do NOT install the product before testing the viewability in the desired location.

16.2 Technical specification

Nominal supply voltage	12 V dc
Operating voltage range	9 to 16 V dc
Current	132 mA
Power consumption	1.6 W
LEN (Refer to the SeaTalk ^{ng} reference manual for further information.)	3
Environmental	Operating temperature: -25°C to 55°C (-13°F to 131°F) Storage temperature range: -30°C to 70°C (-22°F to 158°F) Relative humidity: max: 93% Water proof to IPX6
Display screen	TFT LCD display, 16bit color (64k colors) Resolution: 320x240 Brightness: 700 cd/m ²
Data connections	2 x SeaTalk ^{ng} ports (fulling compliant with NMEA2000 & SeaTalk specifications).
Conformance	<ul style="list-style-type: none"> Europe 2004/108/EC Australia and New Zealand C-Tick, compliance level 2

Chapter 17: Spares and accessories

Chapter contents

- [17.1 Spares and accessories on page 100](#)
- [17.2 SeaTalk^{ng} cabling components on page 100](#)
- [17.3 SeaTalk^{ng} cables and accessories on page 101](#)
- [17.4 SeaTalk accessories on page 102](#)

17.1 Spares and accessories

Part number	Description
R22168	Spare bezel
R22169	p70 Sun cover
R22174	p70r Sun cover

17.2 SeaTalk^{ng} cabling components

SeaTalk^{ng} cabling components and their purposes.

Connection / Cable	Notes
Backbone cable (various lengths)	The main cable carrying data. Spurs from the backbone are used to connect SeaTalk ^{ng} devices.
T-piece connector	Used to make junctions in the backbone to which devices can then be connected.
Terminator	Required at either end of the backbone.
Inline terminator	Used to connect a spur cable directly to the end of a backbone; useful for longer cable runs.
Spur cable	Used to connect devices to the backbone. Devices may be daisy chained or connected directly to the T-pieces.
SeaTalk ^{ng} 5-way connector	Used to branch, split, or make additional connections in SeaTalk or SeaTalk ^{ng} networks.
Blanking plug	Inserted into unused spur connector positions in a 5-way connector or T-piece.

17.3 SeaTalk^{ng} cables and accessories

SeaTalk^{ng} cables and accessories for use with compatible products.

Description	Part No	Notes
SeaTalk ^{ng} starter kit	T70134	Includes: <ul style="list-style-type: none"> • 1 x 5 Way connector (A06064) • 2 x Backbone terminator (A06031) • 1 x 3 m (9.8 ft) spur cable (A06040) • 1 x Power cable (A06049)
SeaTalk ^{ng} Backbone Kit	A25062	Includes: <ul style="list-style-type: none"> • 2 x 5 m (16.4 ft) Backbone cable (A06036) • 1 x 20 m (65.6 ft) Backbone cable (A06037) • 4 x T-piece (A06028) • 2 x Backbone terminator (A06031) • 1 x Power cable (A06049)
SeaTalk ^{ng} 0.4 m (1.3 ft) spur	A06038	
SeaTalk ^{ng} 1 m (3.3 ft) spur	A06039	
SeaTalk ^{ng} 3 m (9.8 ft) spur	A06040	
SeaTalk ^{ng} 5 m (16.4 ft) spur	A06041	
SeaTalk ^{ng} 0.4 m (1.3 ft) elbow spur	A06042	
SeaTalk ^{ng} 0.4 m (1.3 ft) backbone	A06033	
SeaTalk ^{ng} 1 m (3.3 ft) backbone	A06034	
SeaTalk ^{ng} 3 m (9.8 ft) backbone	A06035	
SeaTalk ^{ng} 5 m (16.4 ft) backbone	A06036	
SeaTalk ^{ng} 9 m (29.5 ft) backbone	A06068	
SeaTalk ^{ng} 20 m (65.6 ft) backbone	A06037	
SeaTalk ^{ng} to bare ends 1 m (3.3 ft) spur	A06043	
SeaTalk ^{ng} to bare ends 3 m (9.8 ft) spur	A06044	
SeaTalk ^{ng} Power cable	A06049	
SeaTalk ^{ng} Terminator	A06031	
SeaTalk ^{ng} T-piece	A06028	Provides 1 x spur connection
SeaTalk ^{ng} 5-way connector	A06064	Provides 3 x spur connections
SeaTalk ^{ng} backbone extender	A06030	
SeaTalk to SeaTalk ^{ng} converter kit	E22158	Allows the connection of SeaTalk devices to a SeaTalk ^{ng} system.

Description	Part No	Notes
SeaTalk ^{ng} Inline terminator	A80001	Provides direct connection of a spur cable to the end of a backbone cable. No T-piece required.
SeaTalk ^{ng} Blanking plug	A06032	
ACU / SPX SeaTalk ^{ng} spur cable 0.3 m (1.0 ft)	R12112	Connects an SPX course computer or an ACU to a SeaTalk ^{ng} backbone.
SeaTalk (3 pin) to SeaTalk ^{ng} adaptor cable 0.4 m (1.3 ft)	A06047	
SeaTalk to SeaTalk ^{ng} spur 1 m (3.3 ft) spur	A22164	
SeaTalk2 (5 pin) to SeaTalk ^{ng} adaptor cable 0.4 m (1.3 ft)	A06048	
DeviceNet adaptor cable (Female)	A06045	Allows the connection of NMEA 2000 devices to a SeaTalk ^{ng} system.
DeviceNet adaptor cable (Male)	A06046	Allows the connection of NMEA 2000 devices to a SeaTalk ^{ng} system.
DeviceNet adaptor cable (Female) to bare ends.	E05026	Allows the connection of NMEA 2000 devices to a SeaTalk ^{ng} system.
DeviceNet adaptor cable (Male) to bare ends.	E05027	Allows the connection of NMEA 2000 devices to a SeaTalk ^{ng} system.

17.4 SeaTalk accessories

SeaTalk cables and accessories for use with compatible products.

Description	Part No	Notes
3-way SeaTalk junction box	D244	
1 m (3.28 ft) SeaTalk extension cable	D284	
3 m (9.8 ft) SeaTalk extension cable	D285	
5 m (16.4 ft) SeaTalk extension cable	D286	
9 m (29.5 ft) SeaTalk extension cable	D287	
12 m (39.4 ft) SeaTalk extension cable	E25051	
20 m (65.6 ft) SeaTalk extension cable	D288	

Raymarine[®]
A FLIR COMPANY