



GST™ 43 Thru-Hull Transducer



Installation Instructions

Important Safety Information

⚠ WARNING

See the *Important Safety and Product Information* guide in the product box for product warnings and other important information.

⚠ CAUTION

Failure to install and maintain this equipment in accordance with these instructions could result in damage or injury.

Always wear safety goggles, ear protection, and a dust mask when drilling, cutting, or sanding.

NOTICE

When drilling or cutting, always check what is on the opposite side of the surface.

This equipment should be installed by a qualified marine installer.

To obtain the best performance and to avoid damage to your boat, you must install the Garmin® transducer according to these instructions.

Read all installation instructions before proceeding with the installation. If you experience difficulty during the installation, contact Garmin Product Support.

Registering Your Device

Help us better support you by completing our online registration today.

- Go to <http://my.garmin.com>.
- Keep the original sales receipt, or a photocopy, in a safe place.

Contacting Garmin Product Support

- Go to www.garmin.com/support for in-country support information.
- In the USA, call 913-397-8200 or 1-800-800-1020.
- In the UK, call 0808 238 0000.
- In Europe, call +44 (0) 870 850 1241.

Mounting Location Considerations

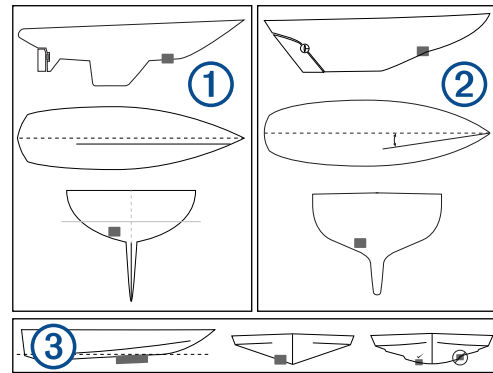

- On fin-keel vessels ①, the transducer should be mounted more than 25 cm (10 in) and less than 75 cm (30 in) in front of the keel and less than 10 cm (4 in) to the side of the centerline.
- On full-keel vessels ②, the transducer should be mounted at a slight angle that aims at the bow, not parallel to the centerline.
- On power boats and hulls with chines ③, the transducer should not be mounted near the edge of sharp hull chines.
- On single-drive boats, the transducer must not be mounted in the path of the propeller.
- On twin-drive boats, the transducer should be mounted between the drives, if possible.
- The transducer should be mounted parallel to the bow-stern axis of your vessel.
- The transducer should be mounted in a location that allows accessibility to the transducer from the inside of the vessel.
- The transducer should not be mounted behind strakes, struts, fittings, water intake or discharge ports, or anything that creates air bubbles or causes the water to become turbulent.
- The transducer should not be mounted in a location where it might be jarred when launching, hauling, or storing.
- The transducer can cause cavitation that can degrade the performance of the boat and damage the propeller.
- The transducer must be in clean (non-turbulent) water for optimal performance.
- If you have a question about the location of the thru-hull transducer, contact your vessel builder or other owners of similar vessels for advice.

Tools Needed

- Drill
- 43 mm (1 11/16 in.) hole saw
- 52 to 55 mm (2 1/16 to 2 3/16 in.) hole saw (cored-fiberglass hull installations)
- Marine sealant
- Silicone grease
- Cable cutter
- Metal file (metal-hull installations)
- Fiberglass cloth and resin (option for sealing a cored-fiberglass hull)
- 43 mm (1 11/16 in.) cylinder, wax, tape, and casting epoxy (option for sealing a cored-fiberglass hull)

Installing the Thru-Hull Transducer

If you are installing the transducer in a cored-fiberglass hull, you must first prepare the hull ([Preparing a Cored-Fiberglass Hull](#)).

- 1 Use a 43 mm (1 11/16 in.) hole saw to cut through the hull at the mounting location.

- 2 Insert the thru-hull fitting in the hull.
- 3 Apply marine sealant to the outer flange of the thru-hull fitting and tighten the nut by hand.
- 4 Slide both rubber O-rings onto the plug.
- 5 Apply silicone grease to the outside of the plug.
- 6 Using a slow, twisting motion, insert the plug into the thru-hull fitting.

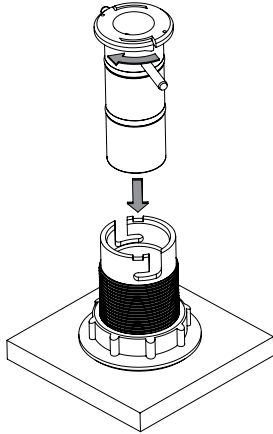

- 7 Verify that the plug is properly seated into the fitting.
- 8 Mount the fitting with the pin at a 90 degree angle to the centerline of the boat.
- 9 After the marine sealant applied in step 3 has cured, remove the nut and apply sealant on the fitting inside the hull.
- 10 Replace the nut and tighten it by hand.
- 11 After installation of the fitting, replace the plug with the actual transducer.

NOTE: It is recommended that you keep the plug for use while cleaning or servicing your transducer.
- 12 Install the wire locking device onto the transducer.

Preparing a Cored-Fiberglass Hull

NOTICE

If the core of a cored-fiberglass hull is not sealed properly, water may seep into the core and severely damage the boat.

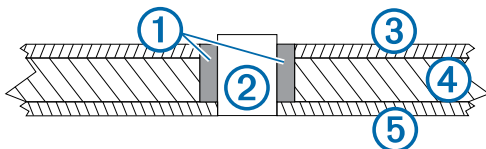

①	Fiberglass or casting epoxy (not included)
②	Cylinder spacer (not included)
③	Inner fiberglass skin
④	Core
⑤	Outer fiberglass skin

- 1 Drill the hole through the hull.
- 2 Seal the core inside the hull using either fiberglass ([Sealing the Hull with Fiberglass](#)) or casting epoxy ([Sealing the Core with Casting Epoxy](#)).

Drilling a Hole in a Cored-Fiberglass Hull

- 1 From inside the boat, drill a 3 mm ($1/8$ in.) pilot hole completely through the hull.
- 2 Examine the pilot hole on the outside of the boat, and select an option:
 - If the pilot hole is not in the correct location, seal the hole with epoxy and repeat step 1.
 - If the pilot hole is in the correct location, use a 43 mm ($1\ 11/16$ in.) hole saw to cut a hole from the outside of the

boat through the outer fiberglass skin only. Do not cut completely through the hull.

- 3 On the inside of the boat, at the pilot hole location, use a hole saw to cut a hole 9 to 12 mm ($3/8$ to $1/2$ in.) larger than the hole you cut in the outside of the boat in step 2.

Cut through the inner fiberglass skin and most of the core, without cutting the outer skin.

NOTE: When cutting the inner fiberglass skin and core, be careful to not cut the outer fiberglass skin, or you will not be able to correctly seal the hull.

- 4 Remove the inner fiberglass skin and core you cut in step 3. You should be able to see the inside of the outer fiberglass skin.
- 5 Sand the inside of the hole and the areas immediately around both the inside and outside fiberglass skin.
- 6 Clean the area using a mild detergent or weak solvent, such as isopropyl alcohol, to remove any dust and dirt.

Sealing the Hull with Fiberglass

- 1 From inside the boat, coat a layer of fiberglass cloth with fiberglass resin and place it inside the hole to seal the core.
- 2 Add layers of fiberglass cloth and resin until the hole is the correct diameter of 43 mm ($1\ 11/16$ in.).
- 3 After the fiberglass has hardened, sand and clean inside and around the hole.

The cored-fiberglass hull is now prepared, and you can complete the transducer installation.

Sealing the Core with Casting Epoxy

To properly seal the core with casting epoxy, you must create a cylinder with a diameter of 43 mm ($1\ 11/16$ in.) to act as a spacer as the epoxy sets.

- 1 Coat a 43 mm ($1\ 11/16$ in.) cylinder with wax.
- 2 Insert the cylinder in the hole through the outer skin and tape it in place on the outside of the boat.
- 3 Fill the space between the cylinder the core with casting epoxy.
- 4 After the epoxy has hardened, remove the cylinder, and sand and clean inside and around the hole.

The cored-fiberglass hull is now prepared, and you can complete the transducer installation.

NMEA 2000® Connection

The transducer connects to the network on your vessel. The GST 43 connects to the NMEA 2000 network through the GST 10 device.

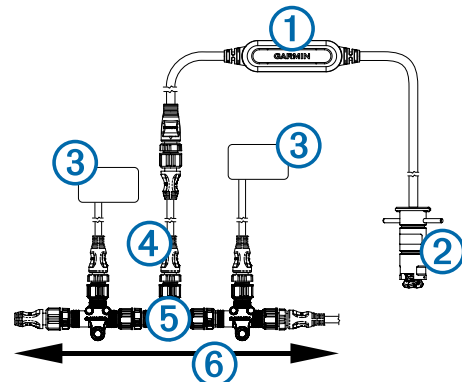

①	GST 10 adapter
②	GST 43 transducer
③	NMEA 2000 device
④	Drop cable

⑤	T-connector
⑥	Existing NMEA 2000 network

Nexus® Network Wiring

When you connect the GST 43 to a Nexus system, you must cut the GST 43 cable to the desired length and connect the wires in the cable to the wires in the Nexus system.

GST 43	Nexus
Green	Green
Yellow	Yellow
White	White
Screen	Screen
Blue	Do not use

Transducer Calibration

NOTE: If you are using a Nexus system, the transducer must be calibrated.

You can use the NexusRace™ software to calibrate the transducer. To download NexusRace software, go to www.garmin.com/NexusRace.

Maintenance

Testing the Installation

NOTICE

You should check your boat for leaks before you leave it in the water for an extended period of time.

The paddlewheel in the transducer measures water flow, and the transducer must be in the water to work properly. The transducer does not provide water flow data when it is out of the water.

- 1 When your boat is in the water, check for leaks near the transducer installation site.
- 2 If leaks are found, apply marine sealant around the installation site, let the sealant cure, and repeat step 1.

Cleaning the Transducer

Aquatic fouling accumulates quickly and can reduce your device's performance.

- 1 Remove the fouling with a soft cloth and mild detergent.
- 2 If the fouling is severe, use a scouring pad or putty knife to remove growth.
- 3 Wipe the device dry.

Specifications

GST 43 Specifications

Dimensions (W x L)	42 x 86 mm (1.65 x 3.38 in.)
Hull thickness	Min. 6 mm (0.24 in.) Max. 42 mm (1.65 in.)
Power input	12 Vdc (From 10 to 16 Vdc)
Power consumption	0.06 W
Temperature range	Operating: From -10 to 70°C (14 to 158°F) Storage: From -35 to 70°C (31 to 158°F)
Speed range	From 0.2 to 30 knots Depending on transducer type: Max. 90 kn
Speed accuracy	± 1%
Transducer cable length	8 m (26.2 ft.)

GST 10 Specifications

Dimensions (W x H x L)	24.7 x 17.0 x 78.6 mm (31/32 x 43/64 x 3 3/32 in.)
Weight	380 g (13.33 oz)

Power input	From 9 to 16 Vdc
Max. power usage	0.9 W
Compass-safe distance	5 cm (2 in.)
Temperature range	From -15 to 70°C (from 5 to 158°F)
Material	PCB overmold: Thermoplastic rubber Cable jacket: PVC Overmold connectors and strain reliefs: PVC
Water rating	IEC 60529 IPX7
Total cable length	4.9 m (16 ft.)
NMEA 2000 (LEN)	1 (50 mA)

NMEA 2000 PGN Information

Type	PGN	Description
Transmit and receive	005932	ISO acknowledgment
	059904	ISO request
	060928	ISO address claim
	126208	NMEA®:Command, request, and acknowledge group function
	126464	Transmit and receive PGN list group function
Transmit	126996	Product information
	128259	Speed: Water reference
	130312	Temperature

Garmin®, the Garmin logo, and Nexus® are trademarks of Garmin Ltd. or its subsidiaries, registered in the USA and other countries. GST™ and NexusRace™ are trademarks of Garmin Ltd. or its subsidiaries. These trademarks may not be used without the express permission of Garmin.

NMEA 2000® and the NMEA 2000 logo are registered trademarks of the National Marine Electronics Association.

