



DESSALATOR

Watermakers

30 years experience in reverse osmosis desalination

Technical Specification

Freedom Model

- DC Powered
- 12/24 V
- Reverse Osmosis
- Modular System



Key features

Automatic fresh water rinsing - keeps the system fresh and clean, prolongs the life of the membranes and back-flushes the pre-filter.

Manual fresh water rinsing - a simple turn of a lever means you can give your water-maker an extra rinse when leaving your boat and when returning after a longer period, keeping your membranes fresh, clean and ready to make pure water.

Automatic fresh water transfer to tank - simplifies operation, letting you relax whilst your tanks are replenished. Also features manual override.

Flow-meter - easily monitor the rate of fresh water production.

Hour-meter - keeps track of hours run to help analyse performance and establish need for service.

Automatic shutdown - with alarm light if the pressure gets too high or if there is no water flow, so the pump cannot run dry.

Over 30 years in the making...



Quiet and reliable – Fitted with CAT high pressure pumps; the best for reliability and low maintenance with up to 5000 hour service intervals. Supplied mounted on a stainless steel chassis with anti-vibration mounts for durability and quiet operation.

Optimum performance – Only Filmtec (Dow Corning) membranes are used for long life, increased output and greater resistance to chlorine.

High quality materials – Carbon fibre membrane tubes eliminate issues with corrosion and are strong and light - maximising long life.



System Specifications

Model	Output (ltr/hr)	Weight (kg)	Amp Draw (12V)	Amp Draw (24V)	Motor Size (Watts)
D30 Freedom	30	35	32	18	370
D60 Freedom	60	38	32	18	370
D100 Freedom	100	45	48	30	600

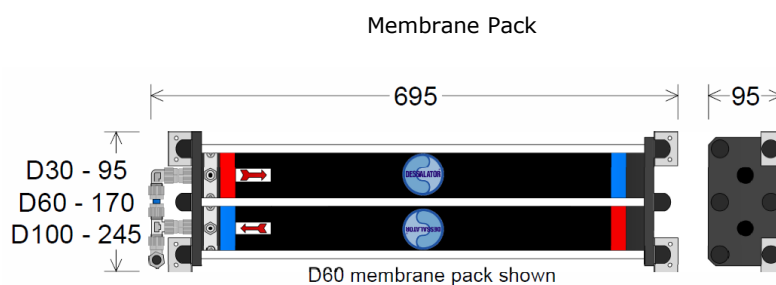
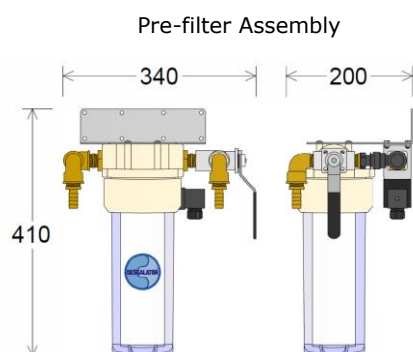
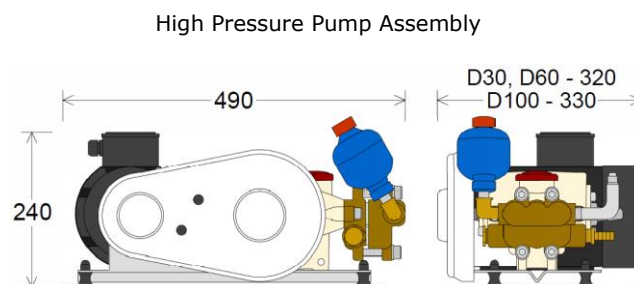
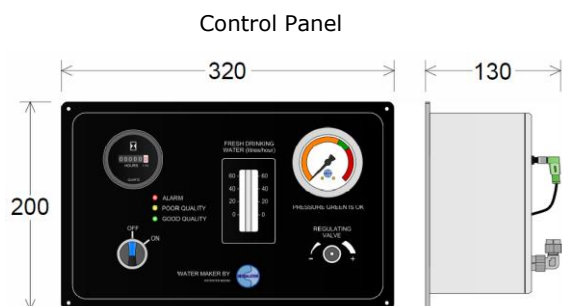

Dimensions in mm

Comprehensive installation pack

Sea water intake fitting: 1/2" Grated scoop with seacock and strainer

Waste water discharge fitting: 1/2" Plain chrome type with seacock + hose tail

Sea water supply hose: 1/2" Suction x 5 meters

Waste water discharge hose: 1/2" Delivery x 6 meters

Product water delivery hose: 3/8" Delivery x 8 meters

Product water output hose: Blue polypropylene pipe

High pressure hose: Flexible hose self-assembly kit

Circuit protection: Fuse holder and fuse - 50A @12V, 25A @24V

Supplied by



Advance Yacht Systems, 9 Fernacre Business Park,
Budds Lane, Romsey, Hampshire, SO51 0HA
Tel: 01794 523900 Fax:01794 523018
Email: info@advanceyacht.co.uk Web: www.advanceyacht.co.uk

